

2012



RC-WOP-B

**RETAIL CATALOG**  
1964-1973 MUSTANG PARTS

We offer quality parts from the top names in the industry



## Scott Drake Guarantee Complete 100% Satisfaction



Whether you are restoring, customizing or enhancing the performance of your vehicle, Scott Drake Enterprises is dedicated to giving you the world's finest parts.

For over 30 years, our engineering techniques have offered unrivaled fit, performance and durability under daily conditions. Everyone at Scott Drake Enterprises strives for your complete satisfaction. If you are not happy with a product, for any reason, simply return it to Scott Drake Enterprises within 30 days of purchase\* and we will replace it - no questions asked. We stand behind our products one hundred percent, so you can sit behind the wheel with pride.

\*Product must be undamaged, in resalable condition.

## Table of Contents

- Accessories..... 2
- Audio ..... 5
- Brakes ..... 7
- Bumpers ..... 18
- Convertible ..... 19
- Cooling ..... 24
- Decals & Striping ..... 28
- Door Parts ..... 35
- Electrical & Lighting ..... 47
- Emblems ..... 63
- Engine ..... 68
- Exhaust System..... 81
- Fuel System ..... 85
- Grille ..... 91
- Hardware ..... 93
- Heater & A/C ..... 99
- Interior & Upholstery ..... 107
- Keys, Locks, & Latches ..... 153
- Literature ..... 157
- Mirrors ..... 160
- Molding ..... 162
- Paint, Tools, & Resto. Supplies ..... 164
- Rubber & Weather Stripping ..... 168
- Sheet Metal & Body Parts ..... 175
- Steering ..... 190
- Suspension ..... 198
- Transmission & Drivetrain..... 203
- Trunk Compartment ..... 215
- Wheels ..... 218
- Windows ..... 222
- Wipers ..... 224

### The Ford Trademark Licensing Program

All the parts represented with the O.L.P. logo are reproduced to the rigid quality standards and regulations of the Ford Motor Company. Working close with Ford and maintaining a strong relationship assures you the highest quality, most accurate reproductions.

Look for the trademark licensing sticker on trademarked products, because with it, you are assured quality and support.



© Copyright 2012 Drake Automotive Group Inc.

This entire catalog, photographs, line drawings, artwork and text is copyrighted.

Use of said material is strictly prohibited without written consent. Violators will be prosecuted to the fullest extent of the law.

Reproduction of this catalog in any form is a violation of the law.

Prices are subject to change without further notice. Additional freight charges may apply. We are not responsible for typographical errors.

# ACCESSORIES

## EXTERIOR

### BUMPER STICKER

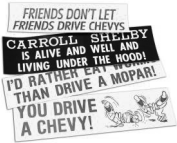

Novelty My Other Car is a Classic Mustang bumper sticker.

**Bumper Sticker**

64-73 My Other Car Is A Classic Mustang . BS-74

### CAR COVER



Our light duty car cover is ideal for short term use, or inside for dust prevention. Our heavy duty and premium covers each

offer 3 layers of protection with the middle layer made from Aprta, a revolutionary new material from Amoco that is extremely water resistant yet breathable to allow condensation to escape. Made in the U.S.A. Universal fit.

**Car Cover**

64-93 Premium (gray) ..... CC-1  
 64-93 Heavy duty (tan) ..... CC-2  
 64-93 Light duty (gray) ..... CC-3

### CAR COVER ANTENNA GROMMET



This neat little grommet snaps together and prevents the car cover from tearing at the antenna.

**Car Cover Antenna Grommet**

64-73 White nylon ..... CC-AG

### CAR COVER CABLE WITH LOCK



Fits all car covers. Durable, multi-strand cable with padlock. Helps prevent theft as well as keeps your cover in place on

windy days.

**Car Cover Cable With Lock**

64-73 ..... CC-CL

### COWL COVER



With Scott Drakes Classic Mustang Cowl Covers, you can eliminate water, dirt, and leaves from entering through

the cowl vent. The use of Poly Methyl Methacrylate plastic (PMMA) helps prevent rusty cowls and soggy carpet that can lead

to rusty floors. New Drake low-profile design easily installed or removed with only a coin.

**Cowl Cover**

64-66 ..... ACC-16741-65  
 67-68 ..... ACC-16741-67  
 69-70 ..... ACC-16741-69

### FENDER COVER

\* Features brilliant three color design, anti-roll tool dam, soft rubberized backing to help prevent scratches and slipping. A small price to pay for protecting costly paint jobs.

**Fender Cover**



64-12 \*  
 ACC-300-MUSTANG

### HEADLIGHT ASSEMBLY GILL TRIM



Plastic injection molded. This is an accessory item available in the mid sixties.

**Headlight Assembly Gill Trim**

64-66 Chrome ..... ACC-610-C  
 64-66 Gold ..... ACC-610-G

### SOLID BRASS LICENSE PLATE FRAME

\* A very nicely chrome-plated, brass license plate frames with licensed logos.

**License Plate Frame, Solid Brass**



64-73: Mustang tri-bar\*  
 ACC-9233100



64-73: Cobra\*  
 ACC-9233205



64-73: Running horse\*  
 ACC-9233270

### FRONT SPOILER



Vacuumed formed impact resistant plastic with textured surface.

64-66 ..... CSZZ-63001A74-A  
 67-68 ..... C7ZZ-63001A74-A  
 69 ..... C9ZZ-63001A74-A  
 70 ..... D0ZZ-63001A74-A  
 71-73 ..... D1ZZ-63001A74-A

### REAR SPOILER



This wing is made of strong fiberglass. Finished smooth

with dull Black paint. Complete kit includes Spoiler, pedestals, pads & mounting hardware. Don't forget prop rod.

69-70 ..... C9ZZ-6344210-K  
 71-73 ..... D1ZZ-6344210-K

See the end of our "Sheet Metal & Body" section for Rear Spoiler mounting Hardware.

### LUGGAGE RACK



Solid rust resistant stainless steel construction. Copy of an original Ford accessory that is functional and

beautifies at the same time.

**Luggage Rack**

64-68 ..... CSZZ-6555100-F

### TIRE PRESSURE GAUGE

\* Quality tire pressure gauge. Chrome plated with black painted rear case. 0 - 60 pounds per inch. Convenient reset button, each is packaged in hinged plastic storage case. All have white face with black numbers, letters and colored logo.

**Tire Pressure Gauge**



64-73: Mustang\*  
 TG-2

**FUN STUFF**

**MUSTANG COOKIES**



Locally baked. Classic cookies baked in the shape of Mustangs and Thunderbirds.



Premium flavor and taste made with all natural flavors, low sodium and low fat. Very attractive packaging great for swap meets or showroom displays.

**Cookies, Mustang**  
64-73 Small box \* ..... 14954 A

**MUSTANG MAGNETIC SIGN**

Look, But Please Don't Touch. Car Show Signs. 3" x 5.25"



**Magnetic Sign, Mustang**



64-73: Classic Mustang\*  
MM-1



64-73: Generic, eyes and hand  
MM-2



64-73: Generic, with cars  
MM-3

**MUSTANG PARTS TAG**



Vintage style mustang parts tags with wire. Great for swap meets or just keeping track



of your own parts.

**Parts Tag, Mustang**  
64-73 With wire, bundles of 100\* .....ACC-200

**HATS**

**HAT**



These high quality embroidered hats make the perfect gift!

**Hat**



64-73: Bone and black, running horse\*  
HAT-183-BONE

**Hat**



64-73: Black, running horse & tri-bar\*  
HAT-197-BLACK



64-73: Pink, running horse & tri-bar\*  
HAT-197-PINK



64-73: Silver blue flames, Ford logo\*  
HAT-F-BK/SF



64-73: Yellow red flames, Ford logo\*  
HAT-F-BK/YF



64-73: Black and tan, Ford logo\*  
HAT-F-BLK



64-73: Blue and khaki, running horse\*  
HAT-M-B/K



64-73: Black and silver, running horse\*  
HAT-M-BK/SIL



64-73: Black and tan, running horse\*  
HAT-M-BLK



64-73: Black, Ford logo\*  
HAT-R-BLK

**DRAKE AUTOMOTIVE GROUP LOGO HAT**



New From Drake is the Official Drake Automotive Group logo Tru-Fit Hat (black). Classic baseball cap style, with

embroidered 2 color Drake Automotive Group logo on front.

**Fire Extinguisher Mount**

S-M ..... HAT-BK-DAG-SMMD  
L-XL ..... HAT-BK-DAG-LXLG

**INTERIOR**

**FIRE EXTINGUISHER MOUNT**



NHRA approved, the Drake Fire Extinguisher Mount is machined from 6061-T6 billet aluminum and features a laser etched logo. Fits various sizes of automobile fire extinguishers.

**Fire Extinguisher Mount**

64-73 ..... FIREX-MNT-DAG  
64-73 ..... FIREX-MNT-DOR

**FIRE EXTINGUISHER MOUNT CLAMPS**



Heavy Duty T-Bar style band clamps. Each set comes with 4 clamps: 2 for securing your fire extinguisher to our Drake Fire Extinguisher

Mount (FIREX-MNT-DAG), and 2 for securing the mount to a roll bar in your vehicle. These clamps fit MaxOut fire extinguishers (MX100R or MX250R).

**Fire Extinguisher Mount Clamps**

64-73 Large, fits MaxOut fire extinguisher  
MX250R ..... FIRE-CLMP-L-DAG  
64-73 Small, fits MaxOut fire extinguisher  
MX100R ..... FIRE-CLMP-S-DAG

**UNDER DASH TISSUE DISPENSER**



**Tissue Dispenser, Under Dash**

64-73 .....C3RZ-19A5491 A

**KEY COVERS & KEY FOBS**

**CHROME/BRUSHED KEY CHAIN**



Very nicely chrome-plated key chains with official logos.

**Key Chain, Chrome/Brushed**



64-73: Running horse & tri-bar\*  
ACC-1033100



64-73: Boss 302\*  
ACC-1033108

**WE PROUDLY FEATURE AUTHENTIC MUSTANG REPRODUCTIONS FROM SCOTT DRAKE ENTERPRISES!**



Key Chain, Chrome/Brushed



64-73: California Special\*  
ACC-1033114



64-73: Cobra\*  
ACC-1033205



64-73: Running horse and Mustang  
script\*  
ACC-1033270



64-73: Mustang GT\*  
ACC-1033275

SHIRTS & SWEATSHIRTS

MUSTANG RACE BRED AND TRUE HORSES SWEATSHIRT



Quality shirts with brilliant silkscreen designs on both front and back. 50%

cotton, 50% polyester.

Sweatshirt, Mustang Race Bred And True Horses

- 64-73 Medium \* .....SS-M
- 64-73 Large \* .....SS-L
- 64-73 XL \* .....SS-XL
- 64-73 XXXL \* .....SS-XXXL

67-68 MUSTANG T-SHIRT



Officially licensed by Ford and made of heavy-duty, 100% cotton. This shirt

features 3 views of the 67/68 Mustang and running horse logo.

T-Shirt, 67-68 Mustang

- 67-68 Large \* .....TS-6768-L
- 67-68 XL \* .....TS-6768-XL
- 67-68 XXL \* .....TS-6768-XXL

69 MUSTANG T-SHIRT



Officially licensed by Ford and made of heavy-duty, 100% cotton. This shirt

features the '69 Mustang and tagline "It was a

very good year"

T-Shirt, 69 Mustang

- 69 XXL \* .....TS-69-XXL

MUSTANG CLASSIC FORD T-SHIRT



Quality shirts with brilliant silkscreened designs on both front and back. Made of

100% cotton.

T-Shirt, Mustang Classic Ford

- 64-73 Small \* .....TS-3S
- 64-73 Medium \* .....TS-3M
- 64-73 Large \* .....TS-3L
- 64-73 XL \* .....TS-3XL
- 64-73 XXL \* .....TS-3XXL
- 64-73 XXXL \* .....TS-3XXXL

MUSTANG EVOLUTION T-SHIRT



Hanes comfort T with bright full color graphics. preshrunk 100% cotton.

T-Shirt, Mustang Evolution

- 64-73 Small \* .....TS-E-S
- 64-73 Medium \* .....TS-E-M
- 64-73 Large \* .....TS-E-L
- 64-73 XL \* .....TS-E-XL
- 64-73 XXL \* .....TS-E-XXL
- 64-73 XXXL \* .....TS-E-XXXL

MUSTANG RACE BRED AND TRUE HORSES T-SHIRT



Quality shirts with brilliant silkscreened designs on both front and back. Our

sweatshirts are made of 50% cotton/50% polyester.

T-Shirt, Mustang Race Bred And True Horses

- 64-73 Small \* .....TS-2S
- 64-73 Medium \* .....TS-2M
- 64-73 Large \* .....TS-2L
- 64-73 XL \* .....TS-2XL
- 64-73 XXL \* .....TS-2XXL

T-Shirt, Mustang Race Bred And True Horses

- 64-73 XXXL \* .....TS-2XXXL

THE BOSS T-SHIRT



High quality, 90% cotton with great new designs.

T-Shirt, The Boss

- 64-73 Medium \* .....TS-BOSS-M
- 64-73 Large \* .....TS-BOSS-L
- 64-73 XL \* .....TS-BOSS-XL
- 64-73 XXL \* .....TS-BOSS-XXL

WOMENS FAST GIRL T-SHIRT



Quality shirts with brilliant silkscreened designs on both front and back. Made of

100% cotton.

T-Shirt, Womens Fast Girl

- 64-73 Small \* .....TS-S-GIRL
- 64-73 Medium \* .....TS-M-GIRL
- 64-73 Large \* .....TS-L-GIRL

WOMENS PURE BRED GIRL T-SHIRT



We haven't forgotten the ladies. This 100% cotton t-shirt will be perfect for

those hot car shows coming up.

T-Shirt, Womens Pure Bred Girl

- 64-73 Small \* .....TS-S-PB
- 64-73 Medium \* .....TS-M-PB
- 64-73 Large \* .....TS-L-PB

YOUTH / INFANT BORN 2 CRUZ T-SHIRT



Quality 100% cotton with beautiful full-color artwork. A must for every child &

grandchild of a Mustang.

T-Shirt, Youth / Infant Born 2 Cruz

- 64-73 Snap Shirt, 12 mo \* .....B2C-12M
- 64-73 Snap Shirt, 24 mo \* .....B2C-24M
- 64-73 Toddler, 2T \* .....B2C-2T
- 64-73 Toddler, 4T \* .....B2C-4T
- 64-73 Toddler, 6/8T \* .....B2C-6/8T
- 64-73 Toddler, 10/12T \* .....B2C-10/12T
- 64-73 Toddler, 14/16T \* .....B2C-14/16T

**YOUTH GROW UP FORD T-SHIRT**



Classic "When I grow up I'm gonna drive a Ford" logo on a quality Tee Shirt



**T-Shirt, Youth Grow Up Ford**

64-73 Kids, 2T*	TS-2T
64-73 Kids, 4T*	TS-4T
64-73 Kids, 6/8T*	TS-68T
64-73 Kids, 10/12T*	TS-1012T

**OFFICIAL DRAKE AUTOMOTIVE GROUP LOGO T-SHIRT**



New From Drake is the Official Drake Automotive Group Logo T-Shirt. This quality "T" boasts the familiar two color Drake

Automotive Group corporate logo screened on the front left breast. The verso sports the large Drake Automotive Group logo with the Scott Drake logo, Drake Muscle Cars logo and Drake Off Road logo with the www. DrakeAutomotiveGroup.com web address. Great for all occasions and pair it up with the official Drake Automotive Group logo cap to make the set complete!

SM	Black	TS-DAG-BK-S
MD	Black	TS-DAG-BK-M
LG	Black	TS-DAG-BK-L
XL	Black	TS-DAG-BK-XL
XXL	Black	TS-DAG-BK-XXL
XXXL	Black	TS-DAG-BK-XXXL
SM	Grey	TS-DAG-GY-S
MD	Grey	TS-DAG-GY-M
LG	Grey	TS-DAG-GY-L
XL	Grey	TS-DAG-GY-XL
XXL	Grey	TS-DAG-GY-XXL
XXXL	Grey	TS-DAG-GY-XXXL

**AUDIO & ELECTRONICS**

**ANTENNAS**

**ANTENNA**

Each antenna offers excellent quality and supreme performance.

**Antenna**



64-68: Reproduction, exact copy  
C5ZZ-18813-B



64-73: Universal power antenna  
S-698



68-73: Not exact copy, similar to original, rectangular base  
C8ZZ-18813-AR



69-70: OEM Shelby  
C5AZ-18813-J

**ANTENNA BASE GROMMET**



High quality compression molded neoprene rubber. Fits round base antennas.

**Antenna Base Grommet**

64-67 .....C5AZ-18A813-A

**ANTENNA LEAD WIRE**



Connects antenna to radio.

**Antenna Lead Wire**

69-70 34"length .....C9ZZ-18812-A

**MISCELLANEOUS AUDIO**

**DASH PANEL REPAIR PLATE**



For that previously hacked radio installation, this panel provides a new dashboard section for installation of a stock radio and an original look. Can be welded into position. Designed to fit under dash pad.

**Dash Panel Repair Plate**

65-66 .....C5ZZ-6504360-PP

**RADIO BEZEL**

**Radio Bezel**



67-68: Black/chrome, without console  
C8ZZ-18842-AR



69-70: Black/chrome  
C9ZZ-6504774-B



69-70: Walnut woodgrain  
C9ZZ-6504774-F



71-73: Black/chrome  
D1ZZ-18842-A

**RADIO KNOB AND DIAL SET**



Pressure die cast construction. Not cheap light weight plastic. Chrome plated and concurs correct. For use on original

**Ford radios.**

**Radio Knob and Dial Set**

64-66	.....C4AZ-18817/30-A
69-70	.....C9ZZ-18817-K

**IPOD STEREO ADAPTER**



Allows you to listen to your Ipod through your compatible car stereo. Use with U.S.A.-1, U.S.A.-6 or U.S.A.-66.

**Stereo Adapter, Ipod**

64-73 Adapter .....ICAMKIT

**WE PROUDLY FEATURE AUTHENTIC MUSTANG REPRODUCTIONS FROM SCOTT DRAKE ENTERPRISES!**



**USB FLASH STEREO ADAPTER**



Allows for hook-up of any device with a USB port to a compatible car stereo.

**Stereo Adapter, USB Flash**  
64-73 USB .....CAM-USB-FLASH

**RADIOS**

**USA-1 RADIO**



From Custom Autosound, the USA-1 radio fits in the original dash without cutting,

and features an attractive bezel with raised Mustang script. Features include: AM/FM, auto reverse cassette, and an auxiliary input for iPod, MP3, satellite radios, etc.

**Radio, USA-1**  
64-66 Black\* .....USA-1-5B  
64-66 Chrome\* .....USA-1-5C  
67-73 Black\* .....USA-1-7B  
67-73 Chrome\* .....USA-1-7C

**USA-2 RADIO**



From Custom Autosound, the USA-2 radio fits in the original dash without cutting,

and features an attractive bezel with raised Mustang script. All the same features as our USA-1 except no cassette.

**Radio, USA-2**  
64-66 Chrome\* .....USA-2-5C  
67-73 Chrome\* .....USA-2-7C

**USA-5 RADIO**



From Custom Autosound, the USA-5 radio fits in the original dash without cutting,

and features an attractive bezel with raised Mustang script. Features include: AM/FM, and auto reverse cassette. Other USA-5 features include: power antenna lead, AM/FM LO/DX selector, and an upgraded AM/FM tuner for optimum reception.

**Radio, USA-5**  
64-66 Black\* .....USA-5-5B

**USA-6 RADIO**



From Custom Autosound, the USA-6 radio fits in the original dash without cutting,

and features an attractive bezel with raised Mustang script. All the same features as our USA-5 except this radio features auxiliary input for iPod, MP3, satellite radios, etc. and no cassette.

**Radio, USA-6**  
64-66 Chrome\* .....USA-6-5C  
67-73 Chrome\* .....USA-6-7C

**USA-66 RADIO**



If you want an authentic looking radio, then the USA-66 is for you. Designed

to look exactly like the 66 Mustang AM-FM option, this radio gives you a direct connection to today's audio options. Features manual tuning AM/FM stereo PLL tuner with auxiliary input for iPod, MP3, satellite radio etc., and will also control an optional 10 disc CD changer (USA-CD10) from the buttons on the radio (No FM Modulation). Push-buttons operate CD & Aux input functions (no radio station pre-sets). Comes with removable labels for the buttons, once you become familiar with the button features just remove the labels to get that OEM look you want.

**Radio, USA-66**  
64-66 \* .....USA-66

**RETRO SOUND RADIO 1**



This is a breakthrough am/fm equipped classic car radio offering flexible mounting options with infiniMount shaft/

bracket system (patent pending) for superior installation flexibility. Remote mountable USB/SD/AUX reader box for MP3/WMA digital file playback from popular flash devices, no ipod needed - just use ANY Flash Drive/Thumb drive or SD card with your digital files on it. This radio also features front and rear panel auxiliary inputs for iPod, MP3, satellite radios, etc., 4 channel amplifier, RCA pre-outs and even includes an under dash bracket for custom or hide away installation options! The 'RF' (radio frequency) remote allows control of the unit from nearby proximity to the vehicle. Vehicle specific trim bezels and metal knobs are sold separately to allow the unit to integrate perfectly into your classic Mustang

(Part #'s RS-65-FPK & RS-67-FPK).  
**RetroSound Radio 1**  
64-73 Chrome (Faceplate & Knobs sold separately) .....RS-6573-1

**RETRO SOUND RADIO CLASSIC**



This am/fm equipped classic car radio offers flexible mounting options with infiniMount shaft/bracket system (patent

pending) for superior installation flexibility. The RetroSound CS900-C features the same quality as the RS-6573-1, but without all the extra features. This radio gets back to the basics: Am/Fm radio with 30 presets and an auxiliary in on the front. Vehicle specific trim bezels and metal knobs are sold separately to allow the unit to integrate perfectly into your classic Mustang (Part #'s RS-65-FPK & RS-67-FPK).

**RetroSound Radio Classic**  
64-73 Chrome (Faceplate & Knobs sold separately) .....RS-CS900-C

**RETRO SOUND RADIO FACE PLATE & KNOBS**



The face plate & knobs to finish off the RetroSound Radio 1 or Classic (above) with a Mustang look.

**RetroSound Radio Face Plate & Knobs**  
64-66 Chrome .....RS-65-FPK  
67-73 Chrome .....RS-67-FPK

**RADIO KNOB AND DIAL SET**



Pressure die cast construction. Not cheap light weight plastic. Chrome plated and concurs correct. For use on original Ford radios.

C4AZ-18817/30-A 64-66  
C9ZZ-18817-K 69-70

**SPEAKERS**

**MOLDED KICK PANEL SPEAKER**



Want more sound without cutting or drilling your classic Mustang? These kickpanel speaker assemblies offer a "no modification" fit. Come fitted with Kenwood

6 1/2" 80 watt speakers, or Pioneer 6 1/2" 150 watt speakers.

**Molded Kick Panel Speaker**

- 64-66 Kenwood, 80 watt, Coupe/Fastback ..... KMC-1
- 64-66 Kenwood, 80 watt, Convertible . KMCV-1
- 67-68 Kenwood, 80 watt, Coupe/Fastback ..... KMC-2
- 67-68 Kenwood, 80 watt, Convertible . KMCV-2
- 65-66 Pioneer, 160 watt, Coupe/Fastback ..... PIO-KMC-1
- 64-66 Pioneer, 160 watt, Convertible ..... PIO-KMCV-1
- 67-68 Pioneer, 160 watt, Coupe/Fastback ..... PIO-KMC-2
- 67-68 Pioneer, 160 watt, Convertible ..... PIO-KMCV-2

**SPEAKER**

High quality speakers, ranging from stock (OEM) style to multi-cone stereo models for terrific sound quality.

**Speaker**



-  64-66: Dash, OEM style replacement  
CSAZ-18808-A
-  64-66: Dash, dual voice coil by Custom Autosound, 140 watts  
CSAZ-18808-DVC
-  64-66: Dash, dual by Kenwood, 40 watts  
CSAZ-18808-KEN
-  64-66: Dash, premium by Retrosound 4X10. 160 watts  
CSAZ-18808-RDVC
-  64-66: Dash, 3" dual cone by Custom Autosound, 60 watts  
CSAZ-18808-ST
-  64-73: Hidden, under/behind seat, 200 watts  
ACC-18808-S
-  64-73: Hidden, two 8" woofers,, rear seat, Custom Autosound  
BSD-65-C

**Speaker**

-  64-73: Subwoofer, 9" width x 14" length x 2.75 height with a built in class D amp. Pushing 100 watts of pure power!  
RS-SUB-8100
-  65-66: Door, 4"x6"  
C6ZZ-18808-A
-  65-68: Rear, 6"x9" stock replacement  
C5ZZ-18808-R
-  67-68: Dash, 5"x7" OEM style replacement  
C7AZ-18808-C
-  67-68: Dash, 5"x7" upgrade dual cone OEM style replacement, stock radios only  
C7AZ-18808-D
-  67-68: Dash, 5"x7" co-axial, 60 watts. Without A/C  
C7AZ-18808-DLX
-  67-68: Dash, Dual voice coil by Custom Autosound, 140 watts, without AC only  
C7AZ-18808-DVC
-  67-68: Dash without air conditioning, Dual by Kenwood, 40 watts  
C7AZ-18808-KEN
-  67-68: Dash, 3" dual cone by Custom Autosound, 60 watts, without AC only  
C7AZ-18808-ST
-  67-73: 5"x7" upgrade dual voice coil by Custom Autosound, 140 watts, with air conditioning  
C7AZ-18808-DVCA
-  67-73: Dash, premium by Retrosound 5X7. 100 watts  
C7AZ-18808-RDVC
-  69-73: Door, 4"x6"  
C9ZZ-18808-A

**DOOR SPEAKER GRILLE**

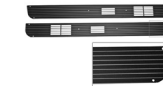
**Speaker Grille, Door**

-  65-66  
C6ZZ-18798-A
-  67-68: Deluxe, also fits 65-66 doors for a custom look, use C7ZN-3301 for proper installation  
C7ZZ-6520956/7A
-  69-70: Stereo script  
C9ZZ-18798-A
-  71-73  
D2ZZ-18978-A

**REAR SPEAKER GRILLE**

-  **Speaker Grille, Rear**  
65-68 .....C5ZZ-18798-A



**BRAKES**

**BRAKE CONVERSION KITS**

**FRONT DISC BRAKE CONVERSION KIT**

Works great with our Power Brake Conversion. All new parts. No core required. These kits do not include a master cylinder or proportioning valve. Depending on year and application, proportioning valve and/or distribution block may be required. These kits do not include instructions and should be installed by someone familiar with basic brake systems. Picture for reference only. See website.

**Disc Brake Conversion Kit, Front**

-  64-66: 6 cylinder, original 4 lug, single piston calipers, will not fit original 14"x5"rims  
DBC-6466-6
-  64-66: 6 cylinder, 5 lug, single piston calipers, will not fit original 14"x5" standard steel rims  
DBC-6466-6-5LUG

Brakes

**WE PROUDLY FEATURE AUTHENTIC MUSTANG REPRODUCTIONS FROM SCOTT DRAKE ENTERPRISES!**





**Disc Brake Conversion Kit, Front**



64-69: V8, 4 piston calipers, will not fit original 14"x5" standard steel rims  
DBC-6569



64-69: V8, single piston calipers, will not fit original 14"x5" standard steel rims  
DBC-6569-SC



64-73: Big Brake Kit, 5 lug, 4-piston calipers, slotted & drilled rotors, requires 17" wheels  
DBC-6573-BBK17



65-69: V8, hi-po slotted rotors, single piston calipers, will not fit original 14"x5" standard steel rims  
DBC-6569-RACE



67-69: 6 Cylinder, 4 lug, single piston calipers, will not fit original 14"x5" standard steel rims  
DBC-6769-6

**REAR DISC BRAKE CONVERSION KIT**

Your classic Mustang will stop even better with a Rear Disc Brake Conversion Kit. Every kit includes full feature calipers with parking brake, splash shields, flex hoses and all the necessary hardware to install disc brakes on your 8" or 9" Ford axle.

**Disc Brake Conversion Kit, Rear**



64-73: Standard duty, 31 spline rear axle  
DBC-A110-1



64-73: Super duty, 28 spline rear axle  
DBC-A111



64-73: Standard duty, 28 spline rear axle  
DBC-A111-2



64-73: Standard rotors, 28 spline  
DBC-REAR



64-73: Drilled and slotted rotors  
DBC-REAR-RACE

**FRONT DISC BRAKE CONVERSION KIT WITH MASTER CYLINDER**

These kits includes everything necessary to completely convert a production drum-brake equipped car to factory disc brakes, including proportioning valve and master cylinder. These will not fit standard stock rims. Above picture is for DBC-A133 and for reference only. Please see website for picture of each kit.

**Disc Brake Conversion Kit with Master Cylinder, Front**



64-66: V8, 4 piston, non-slotted rotors, power, automatic only  
DBC-A120-P



64-66: 6 cylinder, non-power  
DBC-A120-4



64-66: 6 cylinder, dual master cylinder, power, automatic only  
DBC-A120-5



64-66: 8 cylinder, dual master cylinder  
DBC-A120-D



64-66: 8 cylinder manual brakes, single reservoir master Cylinder, OE Design  
DBC-A120-K



65-69: Force 10 4-piston aluminum calipers, slotted rotors  
DBC-A120-2



67-69: non-power  
DBC-A121



67-69: Automatic, Power  
DBC-A121-1



68-69: 8 cylinder, non-power  
DBC-A132-1



68-69: Automatic, power  
DBC-A132-A

**Disc Brake Conversion Kit with Master Cylinder, Front**



68-69: Manual, power  
DBC-A132-M



70: Cast iron single piston, power, includes new disc brake spindles  
DBC-A133



70-73: Force 10 4-piston aluminum calipers, bolts to drum brake spindles  
DBC-A133-3



70-73: Cast Iron 4 piston, manual or power brakes, bolts to drum brake spindles  
DBC-A133-2



71-73: Automatic, power  
DBC-A134

**MASTER CYLINDER ADJUSTABLE PUSH ROD**



Used when brake booster is removed for non power brake application. This rod may require alterations in some applications.

**Push Rod, Master Cylinder Adjustable**

64-69 ..... A21161

**ADJUSTABLE DISC BRAKE PUSH ROD SET**



This changes the pedal ratio so that the pedal does not go down as far before engaging the brakes after you have converted to front manual disc brakes. **This Kit is for Manual Disc Brake Conversions only. Will NOT work with Power Disc Brake Set-up.**

**Disc Brake Push Rod Set, Adjustable**

64-68 Adjustable ..... A21161-DB

**SERIOUS STREET PLUS DISC BRAKE SYSTEM**



Serious Street Plus brake system with aluminum integral hubs and hoses



and Shelby logo calipers. "Serious Street Plus" perfect for stock appearing, Resto-Mod applications where an increase in braking performance is desired while maintaining stock sized wheels. Twin piston calipers and 11? slotted, drilled and zinc washed rotors, have great looks and performance to match! System includes everything necessary to bolt on to factory spindles. All kits are non-stock, special order only.

**Disc Brake System, Serious Street Plus**

- 65-69 Drum Spindle<sup>s</sup> ..... BBS-4261234
- 68-69 Disc Spindle<sup>s</sup> ..... BBS-4261144
- 70-73 Drum Spindle<sup>s</sup> ..... BBS-4261233
- 71-73 Disc Spindle<sup>s</sup> ..... BBS-4261138

**FORCE 10 DISC BRAKE UPGRADE**

**KIT**



This kit will upgrade your standard disc brakes to "Force 10" disc brakes. (Not a drum to disc brake conversion).

- Disc Brake Upgrade Kit, Force 10**  
64-67 .....DBC-A120-10

**BRAKE PEDALS**

**BRAKE AND CLUTCH PEDAL**

**BUSHING**



Made from high strength, wear resistant plastic. Four required for automatic cars, six for manual transmission cars.

- Brake And Clutch Pedal Bushing**  
64-73 .....B7AZ-2471-A

**BRAKE AND CLUTCH PEDAL**

**SUPPORT**



Complete assembly stamped construction includes pressed in bushings.

- Brake And Clutch Pedal Support**  
64-66 ..... C5Z-6501508-A  
67-68 Brake pedal ..... C7Z-6501508-A

**POWER BRAKE PEDAL**



This pedal required when switching over to factory power brakes. This pedal is not required when using our power brake conversions. Note: will fit 1967 but must use

1968 Brake Pad. Will fit 1970 but must use 67-69 Factory Brake Booster.

- Brake Pedal, Power**  
68-69 Automatic trans .....DBC-A21184  
68-69 Manual trans .....DBC-A21185

**BRAKE PEDAL PAD**

Made by Scott Drake with exact detail of the original. Compression molded rubber. Disc brake versions include stainless steel center trim.

**Brake Pedal Pad**



- 64-67: With power drum brakes  
C5Z-2457-E



- 64-67: Drum brakes, automatic transmission  
C5Z-2457-F



- 65-73: Drum brakes, manual transmission  
C5Z-2457-G



- 68-73: Drum brakes, automatic  
C60Z-2457-A

**DISC BRAKE PEDAL PAD**

These reproduction pads are high quality replacements for worn or missing original pads.

**Brake Pedal Pad, Disc**



- 65-67: Disc brakes, automatic transmission  
C5Z-2454-C



- 65-73: Disc brakes, manual transmission  
C5Z-2454-D



- 68-73: Disc brakes, automatic transmission  
D3Z-2454-A

**BRAKE PEDAL PAD TRIM**

Replacement brake pedal pad trim.



- Brake Pedal Pad Trim**  
65-67 Automatic transmission .. C5Z-2A487-B

**Brake Pedal Pad Trim**

- 65-73 Manual transmission ..... D1ZZ-2A487-B  
68-73 Automatic transmission .. C60Z-2A487-A

**BRAKE AND CLUTCH PEDAL AND PEDAL SUPPORT REBUILD KIT**



This kit has everything you need to repair your clutch and brake pedal and pedal support in one easy kit. Includes 378200-K,

C5ZZ-2478-AK and 2 additional B7AZ-2471-A. See Transmission section for Roller bearing upgrade kit.

- Rebuild Kit, Brake And Clutch Pedal And Pedal Support**  
64-70 .....C5Z-2478-MK

**DISC BRAKE COMPONENTS**

**DISC BRAKE DUST SHIELD**

Stamped steel construction. Ready to install.  
**Brake Dust Shield, Disc**



- 65-67  
C5Z-2K004/5-A



- 68-73  
C90Z-2K004/5-A

**DISC BRAKE PAD RETAINER PLATE**

These retainers are designed to keep the disc brake pad inside the caliper on 1967 Mustangs. Can also be used on 1965/66 cars.  
**Brake Pad Retainer Plate, Disc**



- 65-67  
C70Z-2B164-A



- 65-66: Stainless steel  
C5Z-2B127-A

**FRONT DISC BRAKE PADS**



All new disc brake pads are supplied to us by brand name manufacturers for the best in customer satisfaction. Boxed sets

of four pads. Organic linings. Also available in semi-metallic.

- Brake Pads, Front Disc**  
65-67 .....C5Z-2018-BR

Brakes

**WE PROUDLY FEATURE AUTHENTIC MUSTANG REPRODUCTIONS FROM SCOTT DRAKE ENTERPRISES!**



**Brake Pads, Front Disc**

65-67	Semi-metallic	.....	C5ZZ-2018-SM
68-73		.....	D00Z-2018-CR
68-73	Semi-metallic	.....	D00Z-2018-SM
65-69	Pads for -SC and -RACE DBC kits	.....	C5ZZ-2018-SC

**NEW DISC BRAKE CALIPER**



No core charge. These are new calipers using quality parts. They feature new pistons, all new seals, new guide bolts, new hardware

and are 100% pressure tested. Pads are not included. Note: will fit 1965-66, but must purchase 67 hose and brake fitting adapters from your local auto parts store.

**Caliper, New Disc Brake**

65-66	.....	C5ZZ-2B120/1-CR
-------	-------	-----------------

**PREMIUM DISC BRAKE CALIPER**

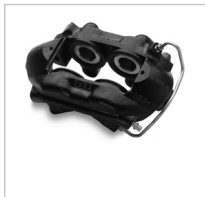

New cast-iron, front 4-piston calipers. These calipers are e-coated internally and externally for maximum corrosion resistance. Built with stainless steel pistons,

stainless steel bleeders, and stainless steel transfer tubes. 100% made in the USA!

C5ZZ-2B120-C	65-66	RH, 3/8" inlet	
C5ZZ-2B121-C	65-66	LH, 3/8" inlet	
C70Z-2B120-C	67	RH, 7/16" inlet	
C70Z-2B121-C	67	RH, 7/16" inlet	

**DISC BRAKE CALIPER CROSS OVER LINE**



Precision made brake lines with correct fittings.

**Caliper Cross Over Line, Disc Brake**

65-67	.....	MCL001	
65-67	Stainless steel	.....	MCL001S

**CALIPER DUST SEAL RETAINER**



Steel retainer. One for each piston is required.

**Caliper Dust Seal Retainer**

65-67	.....	C5ZZ-2A492-A
-------	-------	--------------

**CALIPER MOUNTING BRACKETS**



**Caliper Mounting Brackets**

65-67	Mounting Bracket Set	..	C5ZZ-2B134/5-B
-------	----------------------	----	----------------

**DISC BRAKE CALIPER PISTON**



Quality stainless steel construction.

**Caliper Piston, Disc Brake**

65-66	Steel	.....	C5ZZ-2196-A
-------	-------	-------	-------------

**CALIPER REBUILD KIT**

All necessary parts for overhauling disc brake calipers. Includes all new piston seals and dust boots. Each kit contains the parts for one caliper assembly.

**Caliper Rebuild Kit**



65-67:	One side only
C5ZZ-2B120/1-K	



68-73:	One side only
C8Z-2B120/1-HK	



68-73:	One side only
C8Z-2B120/1-SK	

**DISC BRAKE ROTOR**



Excellent quality replacements. Includes hub, studs, and bearing races.

**Rotor, Disc Brake**

65-67	1 piece	.....	C5ZZ-1102-BR
65-67	Imported	.....	C5ZZ-1102-BRI
68-69	Imported	.....	C80Z-1102-ARI
70-73		.....	D00Z-1102-BR
70-73	Imported	.....	D00Z-1102-BRI

**TURBO ROTOR UPGRADE KIT**



This kit includes SSBC turbo slotted rotors, high performance brake pads and any necessary hardware. bolts directly to stock

spindles and calipers offering a low cost performance upgrade. Front brakes only.

**Rotor Upgrade Kit, Turbo**

65-67	Turbo slotted	.....	DBC-A2360000
68-69	Turbo slotted	.....	DBC-A2360001
70-73	Turbo slotted	.....	DBC-A2360002

**DRUM BRAKE COMPONENTS**

**BRAKE DRUM**



These new brake drums are perfect replacements for tired and thin originals. Front drums do not include studs or a hub.

**Brake Drum**

64-66	Front, 6 cylinder, 4 lug	....	C1DZ-1102-BR
67-70	Front, 6 cylinder	.....	C60Z-1102-GR
64-73	Front, 8 cylinder	.....	C30Z-1102-DR
64-73	Front, 8 cylinder, imported	.....	C30Z-1102-DRI
64-73	Rear, 6 cylinder, 4 lug	....	CODZ-1126-CR
64-73	Rear, 8 cylinder	.....	C30Z-1126-BR
64-73	Rear, 10"x2"	.....	C30Z-1126-AR
64-73	Rear, 10"x2", imported	..	C30Z-1126-BRI

**BRAKE HUB GREASE CAP**



Stamped steel with gold dichromate finish.

**Brake Hub Grease Cap**

64-66	6 cylinder	.....	C3DZ-1131-A
64-69	8 cylinder	.....	B5A-1131-A

**BRAKE SPRING AND HOLD DOWN KIT**



**KIT**

These kits contain all the replacement springs and hold downs required to do a professional job on drum brakes. Kit

includes enough parts for two wheels.

**Brake Spring And Hold Down Kit**

64-70	Rear 9"	.....	C5ZZ-2035-BK
64-71	Front and rear 10"x2"	.....	C5ZZ-2035-CK
64-71	Rear, 10"x1.75"	.....	C5ZZ-2035-DK
64-73	Front 9"	.....	C5ZZ-2035-AK
64-73	64-71 Front and 72-73 rear, 10"x2"	.....	D2ZZ-2035-EK
72-73	Rear, 10"x1.75"	.....	D2ZZ-2035-FK

### DRUM BRAKE HUB



A quality reproduction is now available. Studs not included

#### Drum Brake Hub

- 64-66 6 cylinder ..... C3DZ-1107-HUB
- 64-67 8 cylinder ..... C5ZZ-1107-HUB

### DRUM BRAKE SHOE



These relined shoes have bonded linings made to original manufacturer's specifications. No core required. Sets of 4

shoes.

#### Drum Brake Shoe

- 64-70 Rear, 6 cylinder, except convertible ..... C4AZ-2001-AR
- 64-70 Front, 6 cylinder ..... C4DZ-2001-AR
- 64-70 Rear, 6 cylinder, convertible only ..... C4DZ-2001-AR
- 64-71 Front, V8 & 250 6-cyl small block only .... C70Z-2001-BR
- 64-73 Rear, V8 & 250 6-cyl small block only ..... C7ZZ-2200-AR
- 67-73 Front, 351 and big block only ..... C60Z-2001-AR
- 68-73 Rear, 351 and big block only ..... C60Z-2200-AR

### FRONT WHEEL BEARING AND RACE



U.S. made quality bearings.

#### Front Wheel Bearing and Race

- 64-66 Inner, 6 cylinder, drum brakes ..... C5ZZ-1201-A
- 64-66 Outer, 6 cylinder, drum brakes ..... C5ZZ-1216-A
- 64-69 Inner, V8 ..... B5A-1201-A
- 64-69 Outer, V8 ..... B5A-1216-A
- 70-73 Inner ..... D0ZZ-1201-A
- 70-73 Outer ..... D0ZZ-1216-A

### REAR WHEEL BEARING



High quality part made in the U.S.A.

#### Rear Wheel Bearing

- 64-73 V8, 8 & 9 inch rear end, 28 spline ..... C5ZZ-1225-A

#### Rear Wheel Bearing

- 65-70 6 cylinder, 24 spline ..... C5ZZ-1225-B

### SELF ADJUSTER REPAIR KIT



These kits contain all the parts necessary to refurbish the self adjusting mechanism on drum brakes.

Includes new cable

and guide, ratchet, spring, and all necessary small parts. Kits include everything for one wheel.

#### Self Adjuster Repair Kit

- 64-70 Right hand, 9" ..... C5ZZ-2041-AK
- 64-70 Left hand, 9" ..... C5ZZ-2041-BK
- 64-73 Right hand, 10" ..... C5ZZ-2041-CK
- 64-73 Left hand, 10" ..... C5ZZ-2041-DK

### FRONT DRUM WHEEL STUD



Name brand. Made in the U.S.A.

#### Wheel Stud, Front Drum

- 64-66 Front ..... C3AZ-1107-A
- 64-73 Rear ..... C5ZZ-1107-A

## ELECTRICAL BRAKE PARTS

### BRAKE EXTENSION LEAD



Connects brake master cylinder brake switch to engine gauge harness.

#### Brake Extension Lead

- 64 ..... C4ZZ-2140-EXT

### BRAKE LIGHT SWITCH ADAPTER



This is a high quality precision machined brass adapter.

#### Brake Light Switch Adapter

- 64 ..... DBC-A0813

### BRAKE PRESSURE SWITCH



This switch mounts on the brake junction block to warn the driver of potential brake failure through a warning light on the dash. Won't fit early 67 Mustangs with 1

contact pin.

#### Brake Pressure Switch

- 67-69 Late 67-69 ..... C8AZ-2B264-A

### STOP LIGHT SWITCH



High quality replacement part. Non-original appearance.

#### Stop Light Switch

- 64 Early, 2 prong ..... C4DZ-13480-A
- 65-70 Manual ..... C9ZZ-13480-A
- 67-68 Power disc ..... C9VY-13480-A
- 67-70 Power drum ..... C9ZZ-13480-B
- 71-73 Manual ..... D1ZZ-13480-A
- 71-73 Power ..... D1ZZ-13480-B

## HYDRAULICS

### AXLE VENT, REAR



This concours rear axle vent also serves double duty by securing rear brake hose to axle housing.

#### Axle Vent, Rear

- 64-66 for use w/ non-GT Brake hose C5ZZ-2282-AR ..... C4ZW-4338-A
- 65-73 for use w/ 65-66 GT Brake hose C5ZZ-2282-DR, and all 67-73 ... C8ZW-4338-A

### BRAKE AND FUEL LINE CLIP KIT



Convenient kit which mounts front to rear gas lines and long brake line. Kit includes all clips, fasteners and instructions.

#### Brake And Fuel Line Clip Kit

- 64-67 ..... 380374-MK

### BRAKE DISTRIBUTION BLOCK



These are late model units that are not direct replacements and will require bending brake lines. Highly recommend

when converting 64-66 over to dual chamber master cylinder. D0ZZ version is the same except the bracket is reverse so it is more compatible with original 1970 PDB cars.

#### Brake Distribution Block

- 64-73 ..... C7ZZ-2B257-A
- 70 ..... D0ZZ-2B257-A

Brakes

**WE PROUDLY FEATURE AUTHENTIC MUSTANG REPRODUCTIONS FROM SCOTT DRAKE ENTERPRISES!**



**DISC BRAKE HOSE**

Original equipment style hoses feature Ford Spec fittings. Quality American made replacements. Front.



**Brake Hose, Disc**

- 64-66 Right hand or left hand ...C5ZZ-2078-AR
- 67 Right hand or left hand ..C70Z-2078-BR
- 68-70 Right hand .....C8ZZ-2078-AR
- 68-70 Left hand .....C8ZZ-2078-BR
- 71-73 Right hand .....D1ZZ-2078-CR
- 71-73 Left hand .....D1ZZ-2078-DR

**DRUM BRAKE HOSE**

These original style hoses feature factory specification fittings. Made in the U.S.A.



**Brake Hose, Drum**

- 64 Early 1964, front .....B7AZ-2078-AR
- 64-66 Late 1964, front .....C5ZZ-2078-BR
- 67-70 Front .....C7ZZ-2078-AR
- 71-73 Front .....D1ZZ-2078-ER

**REAR BRAKE HOSE**

Quality American made replacement hose assemblies for the rear brakes.



**Brake Hose, Rear**

- 64-66 All except GT .....C5ZZ-2282-AR
- 65-66 GT or factory dual exhaust .....C5ZZ-2282-DR
- 67-69 All Except Boss and 428 ...C7ZZ-2282-AR
- 68-69 Boss 302/429 & 428CJ ....C9ZZ-2282-AR
- 70 .....D0ZZ-2282-AR
- 71-73 .....D1ZZ-2282-AR

**BRAKE HOSE CLIP KIT**

These clips attach rubber brake hose to mounting bracket.



**Brake Hose Clip Kit**

- 64-73 ..... 78-2814

**BRAKE LINE AND FUEL LINE CLIP**

Exact copy of the hard to find original. This two piece clip is used to mount gas and/or brake line to floor.



**Brake Line And Fuel Line Clip**

- 64-73 .....380374-S

**FRONT BRAKE LINE CLIP AND GROMMET KIT**

These original style clips are the ones that hold your metal brake lines to the firewall. Also includes rubber brake line



grommets which fit in shock tower for brake line protection.

**Brake Line Clip and Grommet Kit, Front**

- 64-67 .....379604-AK
- 67-69 .....379604-BK

**FRONT BRAKE LINE KIT**

Exact copies of the originals. Steel tubing features tin/lead coating and plated zinc chromate fitting. Color coded fittings



like originals.

**Brake Line Kit, Front**

- 64-65 Standard brakes (3 pc) .....MFB001
- 64-65 Standard brakes (3 pc), stainless .....MFB001S
- 64-65 Power brakes .....MFB015
- 64-65 Power brakes, stainless .....MFB015S
- 65-66 GT disc brakes (6 pc) .....MFB003
- 65-66 GT disc brakes (6 pc), stainless . MFB003S
- 66 Standard brakes (3 pc) .....MFB002
- 66 Standard brakes (3 pc), stainless .....MFB002S
- 66 Power brakes .....MFB016
- 66 Power brakes, stainless .....MFB016S
- 67 Power disc brakes only (4 pc, before 2/1/67) w/ proportioning valve at rear of car .....MFB006
- 67 Power disc brakes only (4 pc, before 2/1/67) w/ proportioning valve at rear of car, stainless .....MFB006S
- 67 Drum brakes only (5 pc, before 2/1/67 ... MFB007
- 67 Drum brakes only (5 pc, after 2/1/67), stainless .....MFB007S
- 67 Disc brakes (4 pc, after 2/1/67) ..MFB012
- 67 Disc brakes only (5 pc, after 2/1/67), stainless .....MFB012S
- 67 Drum brakes only (5 pc, after 2/1/67) .... MFB013
- 67 Drum brakes only (5 pc, before 2/1/67), stainless .....MFB013S
- 67 Power drum brakes (5 pc) .....MFB017
- 67 Power drum brakes (5 pc), stainless steel .....MFB017S
- 68-69 Drum brakes only (5 pc) .....MFB004
- 68-69 Drum brakes only (5 pc), stainless .....MFB004S
- 68-69 Power disc brakes only (6 pc) ....MFB005

**Brake Line Kit, Front**

- 68-69 Power disc brakes only (6 pc), stainless .. MFB005S
- 68-69 Power drum brakes .....MFB018
- 69-70 Boss 429, power disk brakes only (4 pc) . MFB010
- 69-70 Boss 429, power disc brakes only (4 pc), stainless .....MFB010S
- 70 Power disc brakes only (4 pc) ....MFB011
- 70 Power disc brakes only (4 pc), stainless .. MFB011S
- 70 Drum brakes .....MFB014
- 70 Drum brakes, stainless steel ....MFB014S
- 71-73 Standard drum brakes only (5 pc) .....MFB008
- 71-73 Standard drum brakes only (5 pc), stainless .....MFB008S
- 71-75 Power disk brakes only (5 pc) ....MFB009
- 71-75 Power disc brakes only (5 pc), stainless .. MFB009S

**FRONT TO REAR BRAKE LINE KIT**

Quality lines with correct fittings. These extra long lines have been gently bent in half so they are FedEx shippable.



**Brake Line Kit, Front To Rear**

- 64-66 Front drum brakes w/ single exhaust .... MLB001
- 64-66 Front drum brakes w/ single exhaust, stainless ..... MLB001S
- 64-66 Front disc brakes w/ dual exhaust ..... MLB003
- 64-66 Front disc brakes w/ dual exhaust, stainless ..... MLB003S
- 64-66 Front disc brakes w/ single exhaust ..... MLB009
- 64-66 Front disc brakes w/ single exhaust, stainless ..... MLB009S
- 64-66 Front drum brakes w/ dual exhaust ..... MLB013
- 64-66 Front drum brakes w/ dual exhaust, stainless ..... MLB013S
- 67 Front disc brakes only,(2 pc, before 2/1/67) w/ proportioning valve at rear of car .....MLB004
- 67 Front disc brakes only (4 pc, before 2/1/67) w/ proportioning valve at rear of car, stainless ..... MLB004S
- 67 Front drum brakes (before 2/1/67) ..... MLB005
- 67 Front drum brakes (before 2/1/67), stainless ..... MLB005S
- 67 Front disc brakes (2 pc, after 2/1/67) ..... MLB008

**Brake Line Kit, Front To Rear**

67	Front disc brakes (2 pc, after 2/1/67), stainless	MLB008S
67	Front drum brakes (after 2/1/67)	MLB012
67	Front drum brakes (after 2/1/67), stainless	MLB012S
68-69	All	MLB002
68-69	All, stainless	MLB002S
70	Front disc brakes	MLB007
70	Front disc brakes, stainless	MLB007S
70	Front drum brakes	MLB010
70	Front drum brakes, stainless	MLB010S
71	Front power or standard drum brakes	MLB014
71	Front power or standard drum brakes, stainless	MLB014S
71	Front disc brakes	MLB015
71	Front disc brakes, stainless	MLB015S
72-73	Front disc brakes	MLB006
72-73	Front disc brakes, stainless	MLB006S
72-73	Front drum brakes	MLB011
72-73	Front drum brakes, stainless	MLB011S

**MASTER CYLINDER BRAKE LINE KIT**



Exact copies of the originals. Steel tubing features tin/lead coating and plated zinc chromate finishing.

**Brake Line Kit, Master Cylinder**

64-65	Standard brakes	MML001
64-65	Standard brakes, stainless	MML001S
64-65	Power drum brakes	MML015
64-65	Power drum brakes, stainless steel	MML015S
65-66	GT disc brakes	MML003
65-66	GT disc brakes, stainless	MML003S
66	Standard brakes	MML002
66	Standard brakes, stainless	MML002S
66	Power drum brakes	MML016
66	Power drum brakes, stainless steel	MML016S
67	Power disc brakes	MML006
67	Power disc brakes, stainless	MML006S
67	Drum brakes only (before 2/1/67)	MML007
67	Drum brakes only (before 2/1/67), stainless	MML007S
67	Disc brakes after 2-1-67	MML012
67	Disc brakes after 2-1-67, stainless steel	MML012S
67	Drum brakes after 2-1-67	MML013
67	Drum brakes after 2-1-67, stainless steel	MML013S
67	Power drum brakes	MML017
67	Power drum brakes, stainless steel	MML017S

**Brake Line Kit, Master Cylinder**

68-69	Standard brakes	MML004
68-69	Standard brakes, stainless	MML004S
68-69	Power disc brakes	MML005
68-69	Power disc brakes, stainless	MML005S
68-69	Power drum brakes	MML018
68-69	Power drum brakes, stainless steel	MML018S
69-70	Boss 429	MML010
69-70	Boss 429, stainless	MML010S
70	Power disc brakes only	MML011
70	Power disc brakes, stainless	MML011S
70	Drum brakes	MML014
70	Drum brakes, stainless steel	MML014S
71-73	Drum brakes only (after 2/1/67)	MML008
71-73	Drum brakes only (after 2/1/67), stainless	MML008S
71-73	Disc brakes (after 2/1/67)	MML009
71-73	Disc brakes (after 2/1/67), stainless	MML009S

**POWER BOOSTER BRAKE LINE KIT**



Power Booster Brake Line

**Brake Line Kit, Power Booster**

64-65	Steel	MPL002
64-65	Stainless	MPL002S
66	Steel	MPL001
66	Stainless	MPL001S

**REAR END HOUSING BRAKE LINE KIT**



These lines run from rear end junction box to each rear wheel cylinder. Precisely bent, exact copy.

**Brake Line Kit, Rear End Housing**

64-66	8 cylinder, except GT	MHB001
64-66	8 cylinder, except GT, stainless	MHB001S
64-66	6 cylinder	MHB002
64-66	6 cylinder, stainless	MHB002S
64-66	8 cylinder, dual exhaust	MHB004
64-66	8 cylinder, dual exhaust, stainless	MHB004S
65-66	8 cylinder, 9"	MHB007
65-66	8 cylinder, 9", stainless	MHB007S
67	8 cylinder, 9"	MHB012
67	8 cylinder, 9", stainless	MHB012S
67-69	8 cylinder, 8"	MHB003
67-69	8 cylinder, 8", stainless	MHB003S
67-69	6 cylinder	MHB010
67-69	6 cylinder, stainless	MHB010S
68	8 cylinder, 9", 28 spline	MHB011

**Brake Line Kit, Rear End Housing**

68	8 cylinder, 9", 28 spline, stainless	MHB011S
68-69	8 cylinder, 9", 31 spline	MHB006
68-69	8 cylinder, 9", 31 spline, stainless	MHB006S
69	8 cylinder, 9", 28 spline	MHB013
69	8 cylinder, 9", 28 spline, stainless	MHB013S
70	8 cylinder, 9"	MHB008
70	8 cylinder, 9", stainless	MHB008S
70	8"	MHB009
70	8", stainless	MHB009S
71-73		MHB005
71-73	Stainless	MHB005S

**BRAKE LINE PRESSURE GAUGE KIT**



A perfect accessory for the disc brake proportioning valve. Monitor brake line pressure. Necessary to diagnose brake stems.

**Brake Line Pressure Gauge Kit**

64-73	7 Piece kit	DBC-A1704
-------	-------------	-----------

**RAKE WHEEL CYLINDER**



All brand new, quality castings and parts.

**Brake Wheel Cylinder**

64	6 cylinder, rear, right hand or left hand	C3DZ-2261-AR
64-66	6 cylinder, rear, right hand or left hand	C5DZ-2261-AR
64-70	6 cylinder, front, right hand	C5DZ-2061-AR
64-70	6 cylinder, front, left hand	C5DZ-2062-AR
64-72	V8, rear, right hand, 29/32"	C30Z-2261-BR
64-72	V8, rear, left hand, 29/32"	C30Z-2262-BR
64-73	V8, front, right hand	C30Z-2061-BR
64-73	V8, front, left hand	C30Z-2062-BR
67-69	351-428, rear, right hand, 13/16"	C7ZZ-2261-AR
67-69	351-428, rear, left hand, 13/16"	C7ZZ-2262-AR
67-69	V8, front, right hand, 1 3/32"	C9TZ-2061-BR
67-69	V8, front, left hand, 1 3/32"	C9TZ-2062-BR
67-73	200/289/302, rear, right hand, 7/8"	C60Z-2261-AR
67-73	200/289/302, rear, left hand, 7/8"	C60Z-2262-AR

**WE PROUDLY FEATURE AUTHENTIC MUSTANG REPRODUCTIONS FROM SCOTT DRAKE ENTERPRISES!**



**DISC BRAKE PROPORTIONING VALVE**



This aftermarket proportioning valve is far superior to the original equipment. Fully adjustable for tuning front

to rear brake bias. Requires some routing modifications of brake lines for proper fit includes adapter fittings.

**Disc Brake Proportioning Valve**

- 64-73 Black anodized ..... A0730
- 64-73 Polished ..... A0730P
- 64-73 ..... CSZZ-2B091-R

**PROPORTIONING VALVE REBUILD KIT**

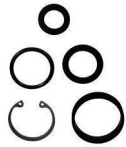

Rebuild your proportioning valve and stop leaks. Kit includes 4 seals and retaining ring. Note: Ford had two versions,

externally identical but internally different. This kit fits the most common later version. Not returnable if opened.

**Proportioning Valve Rebuild Kit**

- 65-66 ..... CSZZ-2B091-K

**MASTER CYLINDERS & POWER ASSIST**

**MASTER CYLINDER BRAKE LINE KIT**



Exact copies of the originals. Steel tubing features tin/lead coating and plated zinc chromate finishing.

**Brake Line Kit, Master Cylinder**

- 64-65 Standard brakes ..... MML001
- 64-65 Standard brakes, stainless ..... MML001S
- 64-65 Power drum brakes ..... MML015
- 64-65 Power drum brakes, stainless steel ..... MML015S
- 65-66 GT disc brakes ..... MML003
- 65-66 GT disc brakes, stainless ..... MML003S
- 66 Standard brakes ..... MML002
- 66 Standard brakes, stainless ..... MML002S
- 66 Power drum brakes ..... MML016
- 66 Power drum brakes, stainless steel ..... MML016S
- 67 Power disc brakes ..... MML006
- 67 Power disc brakes, stainless ... MML006S
- 67 Drum brakes only (before 2/1/67) ..... MML007
- 67 Drum brakes only (before 2/1/67), stainless ..... MML007S

**Brake Line Kit, Master Cylinder**

- 67 Disc brakes after 2-1-67 ..... MML012
- 67 Disc brakes after 2-1-67, stainless steel .. MML012S
- 67 Drum brakes after 2-1-67 ..... MML013
- 67 Drum brakes after 2-1-67, stainless steel MML013S
- 67 Power drum brakes ..... MML017
- 67 Power drum brakes, stainless steel ..... MML017S
- 68-69 Standard brakes ..... MML004
- 68-69 Standard brakes, stainless ..... MML004S
- 68-69 Power disc brakes ..... MML005
- 68-69 Power disc brakes, stainless ... MML005S
- 68-69 Power drum brakes ..... MML018
- 68-69 Power drum brakes, stainless steel ..... MML018S
- 69-70 Boss 429 ..... MML010
- 69-70 Boss 429, stainless ..... MML010S
- 70 Power disc brakes only ..... MML011
- 70 Power disc brakes, stainless ... MML011S
- 70 Drum brakes ..... MML014
- 70 Drum brakes, stainless steel ... MML014S
- 71-73 Drum brakes only (after 2/1/67) ..... MML008
- 71-73 Drum brakes only (after 2/1/67), stainless MML008S
- 71-73 Disc brakes (after 2/1/67) ..... MML009
- 71-73 Disc brakes (after 2/1/67), stainless ..... MML009S

**POWER BOOSTER BRAKE LINE KIT**



Factory Power Booster Brake Line.

**Brake Line Kit, Power Booster**

- 64-65 Steel ..... MPL002
- 64-65 Stainless ..... MPL002S
- 66 Steel ..... MPL001
- 66 Stainless ..... MPL001S

**DISC BRAKE MASTER CYLINDER**



Includes new cap and diaphragm.

**C5ZZ-2140-CR**

**Master Cylinder, Disc Brake**

- 64-66 Manual disc brakes ..... CSZZ-2140-CR
- 64-73 Billet and polished ..... CSZZ-2140-MB
- 64-73 4 wheel disc brakes .... C7ZZ-2140-4WDB
- 67-72 Power disc brakes ..... C8ZZ-2140-AR
- 72-73 Power disc brakes ..... D2ZZ-2140-AR

**DRUM BRAKE MASTER CYLINDER**



Brand new units, not rebuilt. High quality American made parts.

**64-66**

**Master Cylinder, Drum Brake**

- 64-65 Manual drum ..... C4AZ-2140-BR
- 64-65 Power drum ..... CSZZ-2140-BR
- 66 Power drum ..... C6AZ-2140-BR
- 66 Manual drum ..... C6ZZ-2140-BR
- 67-70 Power drum ..... C7ZZ-2140-GR
- 67-70 Manual drum ..... C9AZ-2140-DR
- 72-73 Late 1972, manual drum D2ZZ-2140-CR

**ELECTRIC HIGH PRESSURE MASTER CYLINDER**

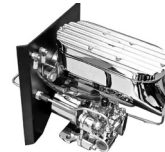

This polished aluminum master cylinder is the answer for Mustang owners with special brake needs. Lack of space

because of a big motor, lack of vacuum caused by big cams, blown or supercharged engines, or are you just looking for a superior looking unit that does not hang out so far from the firewall! This unit is a unique self-contained booster that is not dependent on engine vacuum booster or a steering pump, yet is capable of generating up to 2500 lbs of line pressure. It features a larger bore than most cylinders so it can handle single or multi-piston calipers, but still gives you a solid pedal.

**Master Cylinder, Electric High Pressure**

- 64-73 ..... PBC-EHPMC

**DISC BRAKE MASTER CYLINDER CAP**

Now made by Scott Drake. Our caps feature exact letter stamping detail on top. Rubber diaphragm and bail wire included. Available with a gold cadmium finish like original, or a chrome finish.

**Master Cylinder Cap, Disc Brake**



- 64-66: Disc brake, gold zinc CSZZ-2162-GZ E



- 64-66: Disc brake, chrome CSZZ-2162-DR



- 67-73: Disc brake, gold cadmium C7AZ-2162-B

**Master Cylinder Cap, Disc Brake**



67-73: Disc brake, chrome  
C7AZ-2162-CR

**DRUM BRAKE MASTER CYLINDER CAP**

Made by Scott Drake. This cap features exact details in the lettering. Includes diaphragm, gold, silver or chrome. Our 64-66 cap is also available in a machined 6061 billet version for a custom look.  
**Master Cylinder Cap, Drum Brake**



64-66: Drum brake, billet  
B-2162-A



64-66: Drum brake, chrome  
C5Z-2162-BC



64-66: Drum brake, silver  
C5Z-2162-S



65-66: Drum brake, gold cadmium  
C5Z-2162-B



67-73: Power drum, gold  
C9AZ-2162-B



67-73: Chrome  
D3AZ-2162-C



70-73: Cadmium plated  
D3AZ-2162-A

**MASTER CYLINDER CAP DIAPHRAGM**

Fits underneath master cylinder cap to prevent leaks.  
**Master Cylinder Cap Diaphragm**



64-66: Disc brakes  
C5Z-2167-A

**Master Cylinder Cap Diaphragm**



67-73: Disc brakes  
C7AZ-2167-A



67-73: Drum brakes  
C9AZ-2167-B



70-73: Drum brake, manual  
D3AZ-2167-B

**MASTER CYLINDER PUSHROD BUSHING**



Made of black ABS. Required to reduce brake pedal slop and eliminate noise from metal on metal when applying brakes.

**Master Cylinder Pushrod Bushing**  
65-69 ..... CSDZ-2474-A

**ORIGINAL STYLE BRAKE BOOSTER WITH DISC BRAKE MC**



This original Bendix Style Booster is a direct replacement for 67-69 Cars with original Power Disc Brakes. Will also replace Midland

Style Boosters as well. Can only be used with Power Brake Pedals, not compatible with Manual Brake Pedals. If you wish to run this Booster set-Up on a Manual Brake car then you must order appropriate Power Brake Pedal as well. Will not Fit 1970.

**Original Style Brake Booster with Disc Brake MC**  
67-69 ..... C7ZZ-2005/2140

**FACTORY-STYLE REPLACEMENT POWER BRAKE BOOSTER**



Bendix style replacement boosters. 8" Dual diaphragm. Requires factory power brake pedal.

**Power Brake Booster, Factory-Style Replacement**  
67-69 ..... C7ZZ-2005-BDX  
70 ..... D0ZZ-2005-BDX

**7" POWER BRAKE BOOSTER AND DUAL MASTER CYLINDER**



Compliment to the 65-66 drum to disc conversions. Greatly increases your stopping power. Includes 7" booster

and dual master cylinder. Note: For automatic cars only. Features adjustable push rod.  
**Power Brake Booster and Dual Master Cylinder, 7"**  
64-66 ..... DBC-A28143

**PUSH ROD POWER BRAKE BOOSTER SEAL**



Seals power brake booster push rod to firewall.

**Power Brake Booster Seal, Push Rod**  
65-66 ..... C5ZZ-2021

**POWER BRAKE BOOSTER VACUUM LINE**



Screws into intake manifold fitting and runs to rubber hose from power booster. Quality construction.

**Power Brake Booster Vacuum Line**  
64-65 260, 289 ..... MVB002  
64-65 260, 289 stainless ..... MVB002S  
68-69 302, 351 ..... MVB001  
68-69 302, 351 stainless ..... MVB001S  
68-69 428 ..... MVB003  
68-69 428, stainless ..... MVB003S  
68-69 428 Shelby ..... MVB004  
68-69 428 Shelby, stainless ..... MVB004S

**DUAL CHAMBER POWER BRAKE CONVERSION KIT**



This setup utilizes a new power brake booster with increased sensitivity, new large capacity dual chamber master cylinder, specially designed mounting bracket to allow direct bolt in while retaining original brake pedal assembly and clearance of the shock tower.\* Note: Booster requires a minimum 15 inches of engine vacuum pressure at idle for maximum stopping power. Some high performance high lift camshafts may not create enough vacuum. Stock engine vacuum pressure is 18 inches. 1 year warranty. Picture for reference only. Check website for actual

**Brakes**

**WE PROUDLY FEATURE AUTHENTIC MUSTANG REPRODUCTIONS FROM SCOTT DRAKE ENTERPRISES!**



**15**



picture of each kit. \*(Note: PBC-M1 & PBC-M2 require notching factory shock tower brace. Export brace recommended.) Will not fit cars with factory power brakes. Installation instructions are not included, as this kit should be installed by a trained professional. We recommend part number PBC-MCL to ease installation. Early cars may also require a brake distribution block.

**Power Brake Conversion Kit, Dual Chamber**

- 64-66 Disc Brakes, Automatic Transmission ..... PBC-A1
- 64-66 Disc, auto., aluminum MC w/ RH ports ... PBC-A4
- 64-66 Drum brakes, automatic transmission ... PBC-A2
- 64-66 4 wheel disc brakes, automatic transmission, cast iron M/C ..... PBC-A1-4WDB
- 64-66 4 wheel disc, Manual .... PBC-M1-4WDB
- 64-66 Disc brakes, manual transmission ..... PBC-M1
- 64-66 Drum brakes, manual transmission ..... PBC-M2
- 64-66 Disc brakes with 4 speed transmission, aluminum master ... PBC-M1-ALUM-MC
- 64-66 Manual, with billet master cylinder ..... PBC-M4
- 67-70 Disc Brakes, automatic Transmission ..... PBC-67-1
- 67-70 Drum brakes, automatic transmission ... PBC-67-2
- 67-70 Disc brakes, manual transmission ..... PBC-67-3
- 67-70 Drum brakes, manual transmission ..... PBC-67-4
- 67-70 4 wheel disc brakes, automatic ..... PBC-67-4WDB

**SINGLE CHAMBER POWER BRAKE CONVERSION KIT**



Single chamber master cylinder Power Brake Conversion. Perfect for customers looking for a more original appearance or a

simpler installation. Uses stock manual brake pedal.

**Power Brake Conversion Kit, Single Chamber**

- 64-66 Drum brakes with automatic transmission ..... PBC-A3
- 64-66 Drum brakes with manual transmission . PBC-M3

**POWER BRAKE CONVERSION LINE AND FITTING**



This kit includes two 15 inch straight lines with the correct double flare on one end and fittings for the master cylinder. We

have included extra fittings to accommodate most cars. Although this kit is intended for the trained professional installing our conversion kits, customers with the correct flaring and bending tools will find this kit convenient to use and a time saver.

**Power Brake Conversion Line And Fitting**

- 65-73 Fits all dual chamber master cylinders ... PBC-MCL

**MASTER CYLINDER REBUILD KIT**



**Rebuild kit, Master cylinder**

- 65-66 ..... CSZZ-2140-RBK

**PARKING BRAKE COMPONENTS**

**PARKING BRAKE ASSEMBLY**



Complete assemblies as sold from Ford. Good reproductions includes either plastic pull handle or rubber pad pedal.

**Parking Brake Assembly**

- 64-66 ..... CSZZ-2780-A
- 67-68 ..... C7ZZ-2780-A
- 69 ..... C9ZZ-2780-A
- 70 ..... DOZZ-2780-A

**PARKING BRAKE PULLEY**



The pully that the emergency brake cable rides on.

**Parking Brake Pulley**

- 65-68 Gold anodized ..... OM-2804

**PARKING BRAKE ASSEMBLY BOLTS**



**Parking Brake Assembly Bolts**

- 64-68 ..... 379949-5

**CONCOURS FRONT PARKING BRAKE CABLE**

New by Scott Drake, these are made just like the originals with correct outer casing. Includes firewall seal, firewall bracket and retaining clip.

**Parking Brake Cable, Concours Front**



- 64-66 CSZZ-2853-B



- 67-68 C7ZZ-2853-A

**FRONT PARKING BRAKE CABLE**



Fits from handle to equalizer. One required per car. All fit 6 or 8 cylinder. Cable only. Also available, concours correct

versions for 64-68, see "Concours Front Parking Brake Assemblies".

**Parking Brake Cable, Front**

- 64-66 Economy ..... CSZZ-2853-BR
- 71-73 ..... D1ZZ-2853-AR

**CONCOURS REAR PARKING BRAKE CABLE**



**Parking Brake Cable, Concours**

- 64-65 LH or RH ..... CSZZ-2A635-E
- 66 1 piece ..... C6ZZ-2A635-C

**REAR PARKING BRAKE CABLE**



Fits from equalizer to rear brakes. 2 Req, 6 or 8 cyl, L.H. or R.H.

**Parking Brake Cable, Rear**

- 65-66 1 piece, for rear disc not SSBC, can also fit 1965 but requires additional parts ..... C6ZZ-2A635-RDB
- 67 6 or 8 cyl., left or right hand (2 req.) ..... C7ZZ-2A635-AR
- 67-70 For rear disc brakes not SSBC ..... C7ZZ-2A635-RDB
- 68 6 cylinder, right hand (1 req.) ..... C8ZZ-2A635-BR

**Parking Brake Cable, Rear**

- 68 8 cylinder, right hand (1 req.) ..... C8ZZ-2A635-DR
- 68-69 8 cylinder, left hand (1 req.) ..... C8ZZ-2A635-AR
- 68-70 6 cylinder, left hand (1 req.) ..... C8ZZ-2A635-CR
- 69 6 cylinder, right hand (1 req.) for early style cars built before 2-17-69 ..... C9ZZ-2A635-AR
- 69 8 cylinder, right hand (1 req.) ..... C9ZZ-2A635-CR
- 70-73 8 cylinder, right hand (1 req.) ..... DOZZ-2A635-AR
- 70-73 8 cylinder, left hand (1 req.) ..... DOZZ-2A635-BR

**PARKING BRAKE CABLE BRACKET**



Required to correctly hold the parking brake cable in place.

**Parking Brake Cable Bracket**

- 64-65 ..... C5ZZ-2649-C/D
- 66 ..... C6ZZ-2649-C/D

**PARKING BRAKE CABLE CONNECTOR**



This is the saddle shaped piece that connects the two rear parking brake cables together.

**Parking Brake Cable Connector**

- 67-73 ..... C60Z-2A790-A

**PARKING BRAKE CABLE IDLER**



Now made by Scott Drake! Steel construction with a phosphate finish, this part is made using the original Ford print for exact detail.

**Parking Brake Cable Idler**

- 67-73 ..... C7ZZ-2A808-A

**PARKING BRAKE CABLE IDLER BRACKET**



This bracket mounts to the floor pan and acts as an anchor for the idler. Welding required.

**Parking Brake Cable Idler Bracket**

- 67-73 ..... C7ZZ-2A816-A

**PARKING BRAKE EQUALIZER**

Parking Brake Equalizer. Zinc plated for years of service. Made by Scott Drake.  
**Parking Brake Equalizer**



65  
C5ZZ-2A602-A



66  
C0DD-2A602-A



67-70  
C60Z-2A602-A

**PARKING BRAKE EQUALIZER LEVER**



Made from heavy gauge stamped steel, a quality reproduction.

**Parking Brake Equalizer Lever**

- 65-66 ..... C5ZZ-2A605-A
- 67-68 ..... C7ZZ-2A605-A

**PARKING BRAKE EQUALIZER ROD**



64-66 is a concours reproduction that is zinc plated. 67-68 is an aftermarket replacement in raw steel.

**Parking Brake Equalizer Rod**

- 64-66 ..... B7A-2628-B
- 67-68 ..... C7ZZ-2628-B

**PARKING BRAKE HANDLE**

High quality injection molded parts, mounting lock pin and allen set screw included. Excellent detail in a reproduction part. Black with white "Brake" lettering (1964 - 1966) on ribbed face of handle. Later handles (1967 - 1968) are all black. New improved metal insert. Thicker than original. Includes original drive pin as well as an allen head socket set screw to allow easy removal and installation in the future.

**Parking Brake Handle**



64-66  
C0DZ-2760-B



64-68: Billet  
B-2760-BL

**Parking Brake Handle**



67-68  
C7ZZ-2760-B

**PARKING BRAKE LEVER SPRING**



Exact O.E.M. replacement, not an over the counter universal spring. Painted black.

**Parking Brake Lever Spring**

- 64-66 ..... C5ZZ-2A651-A

**PARKING BRAKE PEDAL PAD**



Made by Scott Drake, this Parking Brake Pad is an exact copy of the original. Molded from wear resistant rubber for years of use.

**Parking Brake Pedal Pad**

- 69-73 Note: Will not fit 1970 Mustang or Cougar  
C9ZZ-2454-A

**PARKING BRAKE PEDAL PAD TRIM**



Made from stainless steel, just like the originals.

**Parking Brake Pedal Pad Trim**

- 69-73 Note: Will not fit 1970 Mustang or Cougar  
C9ZZ-2A487-C

**BUMPERS**

**BUMPER COMPONENTS**

**BUMPER WAVE WASHER**



Stamped of spring steel and zinc plated to stop rust.

**Bumper Wave Washer**

- 64-70 ..... C5ZZ-17A924

**WE PROUDLY FEATURE AUTHENTIC MUSTANG REPRODUCTIONS FROM SCOTT DRAKE ENTERPRISES!**



**BUMPER BOLT**



A variety of bumper bolts are offered to fit your application.

**Bumper Bolt**

- 64-68 Concours ..... C4ZB-17758-A
- 64-68 Standard ..... CSZZ-17758-A
- 64-70 Small ..... 376337-5

**BUMPER BOLT KIT**



These time saving kits contain everything you need to install the front and rear bumpers. Deluxe kits include wave washers.

**Bumper Bolt Kit**

- 64-68 Concours, deluxe 28 piece kit ..... C4ZB-17758-DLXK
- 64-70 Deluxe 28 piece kit ... CSZZ-17758-DLXK
- 64-70 Standard 20 piece kit ..... CSZZ-17758-K
- 69-70 Concours, standard 20 piece kit ..... C9ZZ-17758-K
- 69-73 deluxe 28 piece kit .... C9ZZ-17758-DLXK

**BUMPER GUARD CUSHION**



Used to deaden the noise between the bumper and bumper guards. Quality molded rubber.

**Bumper Guard Cushion**

- 64-66 Set of 4 ..... 379944-S

**BUMPER NUT**



Special serrated flange nut. Attaches to bumper bolts.

**Bumper Nut**

- 64-73 7/16x14 inch threads ..... 375918-S

**FRONT BUMPERS**

**CHROME FRONT BUMPER**



Chrome finish gives the car a nice look. Offers an affordable alternative to expensive re-chroming. Bumper bolts not included. We will

also be offering 64-68 Bumpers with Show Car Chrome in Late 2012 for \$214.95.

**Bumper, Chrome Front**

- 64-66 Made in Taiwan ..... CSZZ-17757-AR
- 67-68 Made in Taiwan ..... C7ZZ-17757-AR
- 69-70 Made in Taiwan ..... C9ZZ-17757-AR
- 71-72 Made in Taiwan ..... D1ZZ-17757

**INNER FRONT BUMPER BRACE**



Stamped from a heavy gauge metal. Painted black.

**Bumper Brace, Inner Front**

- 64-66 Right hand ..... CSZZ-17766-AR
- 64-66 Left hand ..... CSZZ-17767-AR
- 67-68 Right hand ..... C7ZZ-17766-AR
- 67-68 Left hand ..... C7ZZ-17767-AR
- 69-70 Right hand ..... C9ZZ-17766-AR
- 69-70 Left hand ..... C9ZZ-17767-AR
- 71-73 Right hand ..... D1ZZ-17766-AR
- 71-73 Left hand ..... D1ZZ-17767-AR

**OUTER FRONT BUMPER BRACE**



Tubular construction, painted black.

**Bumper Brace, Outer Front**

- 64-66 Right hand ..... CSZZ-17754-AR
- 64-66 Left hand ..... CSZZ-17755-AR
- 67-68 Right hand ..... C7ZZ-17754
- 67-68 Left hand ..... C7ZZ-17755
- 69-70 Right hand ..... C9ZZ-17754-AR
- 69-70 Left hand ..... C9ZZ-17755-AR

**BUMPER BRACE MOUNTING HARDWARE, FRONT**



Concours correct for 1964-66 Mustangs, but will also fit 67-73 Mustangs. Mounts bumper braces to frame rail.

**Bumper Brace Mounting Hardware, Front**

- 64-66 ..... 372434-FBK

**FRONT BUMPER BRACKET**



Steel stamping. Secures bumper to front fender side.

**Bumper Bracket, Front**

- 64-66 Right hand ..... CSZZ-17A869-A
- 64-66 Left hand ..... CSZZ-17A870-A

**Bumper Bracket, Front**

- 67-68 Right hand ..... C7ZZ-17A869-A
- 67-68 Left hand ..... C7ZZ-17A870-A
- 69-70 Right hand or left hand .C9ZZ-17B762-A

**FRONT BUMPER GUARD**



Features a heavy gage steel stamping. These are the best on the market. Flawless chrome. Sold in pairs.

**Bumper Guard, Front**

- 64-66 Concours ..... CSZZ-17996/7-CB
- 67-68 w/ trim holes ..... C7ZZ-17996/7-A
- 67-68 Without trim holes ..... C7ZZ-17996/7-B

**FRONT BUMPER GUARD BRACKET**



Die stamped from heavy gauge steel and painted black. Perfect copy. Mounts on inner bumper brace.

**Bumper Guard Bracket, Front**

- 64-66 ..... CSZZ-17B794-A

**FRONT BUMPER GUARD HARDWARE KIT**

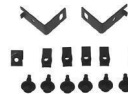

These kits make mounting bumper guards a breeze.

**Bumper Guard Hardware Kit, Front**

- 64-66 Bolt kit ..... 359530-K
- 64-66 Clip kit ..... 370328-K
- 64-66 Bolt, bracket and clip kit CSZZ-17794-KIT

**FRONT BUMPER GUARD TRIM**



E.P.D.M. rubber featuring steel insert and mounting studs. Steel insert is cadmium plated to prevent rust. An excellent

reproduction.

**Bumper Guard Trim, Front**

- 67 ..... C7ZZ-17A812-A

**BUMPER PADS**

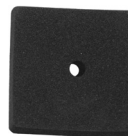

Fender/bumper pads. Sold in bulk.

**Bumper Pads**

- 64-66 ..... CSZZ-16426

## REAR BUMPERS

### CHROME REAR BUMPER



Chrome finish gives the car a nice look. Both versions offer an affordable alternative to expensive re-chroming. Bumper bolts not included. We will also be offering 64-68 Bumpers with Show Car Chrome in Late 2012 for \$214.95.

#### Bumper, Chrome Rear

64-66	Made in Taiwan	.....C5ZZ-17906-AR
67-68	Made in Taiwan	.....C7ZZ-17906-AR
69-70	Made in Taiwan	.....C9ZZ-17906-AR
71-73	Made in Taiwan	.....D1ZZ-17906-A

### REAR BUMPER BODY PAD



Our die cut foam rubber donuts help cushion the brace from the tail panel.

#### Bumper Body Pad, Rear

65-73	.....C5ZZ-6540996
-------	-------------------

### REAR BUMPER BRACE



Stamped steel. Painted black. A nice reproduction. New tooling! Now features the same thickness as the originals.

#### Bumper Brace, Rear

64-66	.....C5ZZ-17A750-AR
67-68	.....C7ZZ-17A750-AR
69-70	.....C9ZZ-17A750-AR
71-72	Right hand .....D1ZZ-17A750-AR
71-72	Left hand .....D1ZZ-17A751-AR

### REAR BUMPER BRACE MOUNTING HARDWARE



Concours correct for 1964-66 Mustangs, but will also fit 67-73 Mustangs.

#### Bumper Brace Mounting Hardware, Rear

64-66	.....372434-RBK
-------	-----------------

### REAR BUMPER GUARD



Precision steel stamping from heavy gage steel.

#### Bumper Guard, Rear

64-66	Chrome	.....C5ZZ-17984-C
67-68	Black w/trim	.....C7ZZ-17984-AR
67-68	Chrome w/trim	.....C7ZZ-17984-CR

### REAR BUMPER GUARD BRACKET



Steel stamping and painted black. Just like originals.

#### Bumper Guard Bracket, Rear

64-66	.....C5ZZ-17B876/7-A
67-68	.....C7ZZ-17B876/7-A

### REAR BUMPER GUARD TRIM

Trim that attaches to the rear bumper guards, protecting the chrome.

#### Bumper Guard Trim, Rear



67-68	.....C7ZZ-17A807-A
-------	--------------------



73	.....D1ZZ-17A812
----	------------------

### REAR BUMPER LICENSE LAMP



Mounts on rear bumper. Good copy of original, includes lens, bulb and correct wiring pigtail.

#### Bumper License Lamp, Rear

64-70	.....C5ZZ-13550-A
71-73	.....D1ZZ-13550-A

## CONVERTIBLE PARTS

### BOOTS

#### CONVERTIBLE TOP BOOT



Made from original patterns for a wrinkle free look. Features perfect fit and long lasting vinyl. Includes foam pads. Will not fit

Shelby.

#### Convertible Top Boot

64-65	Medium Blue	.....C5ZZ-7654400-BL
64-65	Bright Red	.....C5ZZ-7654400-RD
64-66	Black	.....C5ZZ-7654400-BK
64-66	Emberglow	.....C5ZZ-7654400-EM
64-66	Ivy gold	.....C5ZZ-7654400-IG
64-66	Palomino	.....C5ZZ-7654400-PA
64-66	White	.....C5ZZ-7654400-WT
66	Dark red	.....C5ZZ-7654400-DR
66	Light blue	.....C5ZZ-7654400-LB
66	Parchment	.....C5ZZ-7654400-PR
66	Turquoise	.....C5ZZ-7654400-TQ
67	Black	.....C7ZZ-7654400-BK
67	Dark red	.....C7ZZ-7654400-DR
67	Ivy gold	.....C7ZZ-7654400-IG
67	Light blue	.....C7ZZ-7654400-LB
67	Palomino	.....C7ZZ-7654400-PA
67	Parchment	.....C7ZZ-7654400-PR
67	Saddle	.....C7ZZ-7654400-SA
67	Turquoise	.....C7ZZ-7654400-TQ
67	White	.....C7ZZ-7654400-WT
68	Black	.....C8ZZ-7654400-BK
68	Dark red	.....C8ZZ-7654400-DR
68	Ivy gold	.....C8ZZ-7654400-IG
68	Light blue	.....C8ZZ-7654400-LB
68	Maroon	.....C8ZZ-7654400-MR
68	Palomino	.....C8ZZ-7654400-PA
68	Parchment	.....C8ZZ-7654400-PR
68	Saddle	.....C8ZZ-7654400-SA
68	Turquoise	.....C8ZZ-7654400-TQ
68	White	.....C8ZZ-7654400-WT
69	Dark red	.....C9ZZ-7654400-DR
69	Ivy gold	.....C9ZZ-7654400-IG
69	Light blue	.....C9ZZ-7654400-LB
69	Nugget gold	.....C9ZZ-7654400-NG
69-70	Black	.....C9ZZ-7654400-BK
69-70	White	.....C9ZZ-7654400-WT
70	Blue	.....C9ZZ-7654400-BL
70	Ginger	.....C9ZZ-7654400-GI
70	Ivy	.....C9ZZ-7654400-IV
70	Vermillion	.....C9ZZ-7654400-VE

Convertible

**WE PROUDLY FEATURE AUTHENTIC MUSTANG REPRODUCTIONS FROM SCOTT DRAKE ENTERPRISES!**



**Convertible Top Boot**

71-73 Black .....	D1ZZ-7654400-BK
71-73 Blue .....	D1ZZ-7654400-BL
71-73 Ginger .....	D1ZZ-7654400-GI
71-73 Green .....	D1ZZ-7654400-GR
71-73 Vermillion .....	D1ZZ-7654400-VE
71-73 White .....	D1ZZ-7654400-WT

**CONVERTIBLE TOP BOOT BAG**



Heavy vinyl, felt-backed construction. Protects top boot from dirt and grime.

**Convertible Top Boot Bag**

64-73 Black .....	BB-FM-BK
64-73 Plaid .....	BB-FM-PLD
64-73 Speckled .....	BB-FM-SPK
64-73 White .....	BB-FM-WT

**CONVERTIBLE TOP BOOT SNAP KIT**



Great quality kit. This one features 17 snaps, with correct length and 17 retainers. Snaps are made from stainless steel so they

will not rust! 64-66 pictured.

**Convertible Top Boot Snap Kit**

64-66 .....	359274-SK
67 .....	359274-S67

**ELECTRICAL**

**BEZEL INSTALLATION TOOL**



This dedicated tool is perfect for installing or removing the chrome bezel on our 1967 Mustang Convertible Top Switch, or the

bezel on our 2010 Mustang Billet Antenna.

**Bezel Installation Tool**

67 .....	1967 CV Top Switch Bezel & 2010 Antenna Bezel .....	T-67
----------	---	------

**CONVERTIBLE TOP HARNESS**



This is the main harness for the power convertible top. Made in the USA. Correct color coded wires and factory style loom

cover includes circuit breaker. Note: 64-66 version will also work on 67-68.

**Convertible Top Harness**

64-68 Concurrency for 64-66 .....	C5ZZ-7615A668
-----------------------------------	---------------

**Convertible Top Harness**

67-68 Concurrency for 67-68 .....	C7ZZ-7615A668
-----------------------------------	---------------

**UNDER HOOD CONVERTIBLE TOP HARNESS**



This wiring harness links the convertible top switch to the circuit breaker under the hood on 1964 through 1966

Mustangs.

**Convertible Top Harness, Under Hood**

64-66 .....	C4DZ-15668-B
-------------	--------------

**CONVERTIBLE TOP SWITCH**

Exact copy from Scott Drake. Note: 64-66 knob & bezel sold separately

**Convertible Top Switch**



64-66 .....	C4DZ-15668-A
-------------	--------------



67: Includes bezel and knob .....	C7Z-15668-A
-----------------------------------	-------------



69-70 .....	C9Z-15668
-------------	-----------



71-73 .....	D1ZZ-15668
-------------	------------

**CONVERTIBLE TOP SWITCH BEZEL AND KNOB**



Quality chrome plated with black painted "UP" and "DN" markings. Retaining nuts included.

**Convertible Top Switch Bezel and Knob**

64-66 .....	C4DZ-10852-K
-------------	--------------

**CONVERTIBLE TOP TO SWITCH CIRCUIT BREAKER**



This wiring harness links the convertible top switch to the circuit breaker under the hood on 1964 through 1966

Mustangs.

**Convertible Top To Switch Circuit Breaker**

65-70 Does not fit 66 .....	C5ZZ-14448-A
66 .....	C6ZZ-14448-A

**HYDRAULICS**

**CONVERTIBLE PUMP MOTOR AND RESEVIOR**



All new, not rebuilt. Excellent U.S.A. quality

**Convertible Pump Motor And Resevior**

64-73 .....	C4DZ-765337-A
-------------	---------------

**CONVERTIBLE TOP HYDRAULIC CYLINDER**



These are all new, not rebuilt or off the shelf generic replacements. Guaranteed for one year. Made in U.S.A.

**Convertible Top Hydraulic Cylinder**

64-70 USA .....	C5ZZ-7650600-AR
64-70 Import .....	C5ZZ-7650600-A
71 USA .....	D1ZZ-7650600-A
72-73 Left hand USA .....	D2ZZ-7650600-A
72-73 Right hand USA .....	D2ZZ-7650601-A

**CONVERTIBLE TOP HYDRAULIC HOSE LINE**



Clear hydraulic hoses that have the correct brass machined fittings.

**Convertible Top Hydraulic Hose Line**

64-70 .....	C5ZZ-7653456-A
-------------	----------------

**LATCHES AND COMPONENTS**

**CONVERTIBLE TOP CLAMP TRUSS HEAD REPAIR KIT**



Designed for easy installation. Does not require top disassembly.

**Convertible Top Clamp Truss Head Repair Kit**

65-68 .....	380348-S
-------------	----------

**CONVERTIBLE TOP CLAMP TRUSS HEAD SCREW**



Concours correct. Requires top to be disassembled.

Convertible Top Clamp Truss Head Screw  
64-68 ..... 380348-SK

**CONVERTIBLE TOP CLEVIS PIN KIT**



This complete 10 piece kit includes nylon bushings, chrome pivot rivets, locking wave washers, and locking clevis pins.

Convertible Top Clevis Pin Kit  
64-70 ..... 378887-SK

**CONVERTIBLE TOP DOWEL PIN**



Helps top alignment as top goes down onto our visor brackets.

Convertible Top Dowel Pin  
64-68 ..... CSZZ-76514A38-B

**CONVERTIBLE TOP HOLD DOWN CLAMP**



Made by Scott Drake with exacting details. Fits 1965-68 Convertibles with manual tops.

Convertible Top Hold Down Clamp  
64-68 Right hand and left hand ..... CSZZ-7650500/1D  
64-68 Right hand ..... CSZZ-7650500-D  
64-68 Left hand ..... CSZZ-7650501-D

**CONVERTIBLE TOP HOOK**



Beautifully chrome plated, features correct thread size.

Convertible Top Hook  
64-66 ..... CSZZ-7650536-A  
67-73 ..... C6AZ-76506A48-A

**CONVERTIBLE TOP LATCH ASSEMBLY**



Finished assembly ready to install. Features hold down clamp handle, pivots, spring and top hook.

Convertible Top Latch Assembly  
64-68 Right hand ..... CSZZ-7650508-K  
64-68 Left hand ..... CSZZ-7650509-K

**CONVERTIBLE TOP LATCH HANDLE**

New Lower Price!



Convertible Top Latch Handle  
71-73 Right hand ..... D1ZZ-7650508-A  
71-73 Left hand ..... D1ZZ-7650509-A

**CONVERTIBLE TOP LATCH MOUNTING BASE**



This is the base that the latch handle mounts to on the convertible top frame. Sold as a pair.

Convertible Top Latch Mounting Base  
64-67 ..... CSZB-7650500/1B

**CONVERTIBLE TOP LATCH SPRING**



These are the 3 inch springs that keep tension on the convertible top latches, allowing them to lock in place. Sold

as a pair.  
Convertible Top Latch Spring  
64-73 ..... CSZZ-7650572-A

**MISCELLANEOUS PARTS**

**CONVERTIBLE QUARTER PANEL SNAP KIT**



Used to mount top boot to quarter panels. Limited supply! Tubular design must be crimped on. 6 pc kit, exact copy.

Convertible Quarter Panel Snap Kit  
64-68 ..... CSZZ-7602628-A

**CONVERTIBLE TOP TENSION CABLE**



A quality rust proof stainless steel cable which features all the correct hardware.

Convertible Top Tension Cable  
64-65 Stud type ..... CSZZ-7652806-A  
65-68 Spring type ..... CSZZ-7652806-B  
69-70 ..... C9ZZ-7652806-A

**CONVERTIBLE TOP REPAIR MANUAL**



The convertible top is the most complicated part of any car. Manual features complete top replacement, adjustments, servicing,

electrical and trouble-shooting. 15 pages soft bond.  
Manual, Convertible Top Repair  
64-66 ..... MP-14

**MOLDINGS**

**CONVERTIBLE HEADER MOLDING**

Good fitting alternative to the original.



Convertible Header Molding  
64-67 Chrome ..... CSZZ-7603606-A  
68 Chrome ..... C8ZZ-7603606-A

**CONVERTIBLE TOP BOOT REAR MOLDING**

Features polished stainless steel finish and a great fit. Snaps not included.



Convertible Top Boot Rear Molding  
64-66 ..... CSZZ-76423A20-A

**CONVERTIBLE TOP BOOT SIDE MOLDING**

Now made by Scott Drake. Features beautiful chrome finish and a great fit. Snaps not included. These are superior to



the cheap imported versions available on the

Convertible

**WE PROUDLY FEATURE AUTHENTIC MUSTANG REPRODUCTIONS FROM SCOTT DRAKE ENTERPRISES!**



market.  
**Convertible Top Boot Side Molding**  
 64-66 ..... CSZZ-76423A18/9

## REAR WINDOW

### GLASS CONVERTIBLE TOP REAR WINDOW



**EZON**  
 AUTO TOPS, Inc.

Glass rear windows greatly enhance rear visibility. They are not prone to scratching, cracking or yellowing due to exposure to the sun.

#### Convertible Top Rear Window, Glass

64-66 Black ..... CSZZ-7652500-GB  
 64-66 White ..... CSZZ-7652500-GW  
 67-70 Black ..... C7ZZ-7652500-GB  
 67-70 White ..... C7ZZ-7652500-GW  
 69-70 White ..... C9ZZ-7652500-GW  
 71-73 Black ..... D1ZZ-7652500-GB  
 71-73 White ..... D1ZZ-7652500-GW

### PLASTIC CONVERTIBLE TOP REAR WINDOW



**EZON**  
 AUTO TOPS, Inc.

Plastic windows feature heavy duty 40 gauge clear plastic trimmed with premium 38 ounce material and a zipper assembly.

#### Convertible Top Rear Window, Plastic

64-66 Black ..... CSZZ-7652500-PB  
 64-66 White ..... CSZZ-7652500-PW  
 67-68 Black ..... C7ZZ-7652500-PB  
 67-68 White ..... C7ZZ-7652500-PW  
 71-73 Black ..... D1ZZ-7652500-PB  
 71-73 White ..... D1ZZ-7652500-PW

## SUN VISORS & COMPONENTS

### CONVERTIBLE SUN VISOR BRACKET AND ROD

Show car quality with triple chrome plating. Includes L.H. & R.H. brackets with attached visor pivot rods.

#### Convertible Sun Visor Bracket And Rod



64-66  
 CSZZ-7604144/5

#### Convertible Sun Visor Bracket And Rod



67-68: Chrome  
 C7ZZ-7604144/5A

### CONVERTIBLE VISOR PIVOT ARM



Easy repair kit for those of you who want an economical fix.

#### Convertible Visor Pivot Arm

64-66 ..... CSZZ-7604144-P

### CONVERTIBLE VISOR ROD



Chrome plated 4-piece kit. Pushes in padded sun visors.

#### Convertible Visor Rod

64-66 ..... CSZZ-7604114-K

### CONVERTIBLE SUN VISOR



Convertible visors are covered in the original Sierra Grain vinyl.

#### Sun Visor, Convertible

64-65 Medium blue ..... CSZZ-7604104-BL  
 64-65 Bright red ..... CSZZ-7604104-BR  
 64-66 Black ..... CSZZ-7604104-BK  
 64-66 Emberglo ..... CSZZ-7604104-EM  
 64-66 Ivy gold ..... CSZZ-7604104-IG  
 64-66 Palamino ..... CSZZ-7604104-PA  
 64-66 Turquoise ..... CSZZ-7604104-TQ  
 64-66 White ..... CSZZ-7604104-WT  
 65-66 Aqua ..... CSZZ-7604104-AQ  
 66 Dark red ..... CSZZ-7604104-DR  
 66 Light blue ..... CSZZ-7604104-LB  
 66 Parchment ..... CSZZ-7604104-PR  
 67-68 Aqua ..... C7ZZ-7604104-AQ  
 67-68 Black ..... C7ZZ-7604104-BK  
 67-68 Dark blue ..... C7ZZ-7604104-DB  
 67-68 Dark red ..... C7ZZ-7604104-DR  
 67-68 Ivy gold ..... C7ZZ-7604104-IG  
 67-68 Light blue ..... C7ZZ-7604104-LB  
 67-68 Parchment ..... C7ZZ-7604104-PR  
 67-68 Saddle ..... C7ZZ-7604104-SA  
 67-68 White ..... C7ZZ-7604104-WT  
 68 Maroon ..... C7ZZ-7604104-MR  
 68 Nugget gold ..... C7ZZ-7604104-NG  
 69-73 Black ..... C9ZZ-7604104-BK  
 69-73 Blue ..... C9ZZ-7604104-BL  
 69-73 Dark ivy ..... C9ZZ-7604104-DI

#### Sun Visor, Convertible

69-73 Dark red ..... C9ZZ-7604104-DR  
 69-73 Green ..... C9ZZ-7604104-GR  
 69-73 Ivy gold ..... C9ZZ-7604104-IG  
 69-73 Light blue ..... C9ZZ-7604104-LB  
 69-73 Nugget gold ..... C9ZZ-7604104-LN  
 69-73 Parchment ..... C9ZZ-7604104-PR  
 69-73 Vermillion ..... C9ZZ-7604104-VE  
 69-73 White ..... C9ZZ-7604104-WT

## TOPS, PADS & TACK STRIPS

### BULK CONVERTIBLE TACK STRIP



Bulk Conv Tack Strip/50 FT roll. Fits front only.

#### Convertible Tack Strip, Bulk

64-73 ..... CSZZ-76-TS-BULK

### CONVERTIBLE TOP PAD



Quality construction. Used to cushion and protect top vinyl from excessive wear from side rails.

#### Convertible Top Pad

64-70 Black ..... CSZZ-7652875-BK  
 69-70 Black ..... C9ZZ-7652875-BK  
 71-73 Black ..... D1ZZ-7652875-BK

### CONVERTIBLE TOP REAR TACK STRIP KIT



Metal tack strip complete with cardboard insert for proper staple fastening.

#### Convertible Top Rear Tack Strip Kit

64 ..... MM-043  
 65-66 ..... MM-143  
 67-68 ..... MM-243  
 69-70 Rear ..... MM-343  
 71-73 Convertible ..... MM-443

**CV TOP W/ GLASS BACK WINDOW**



Glass rear windows enhance rear visibility. They are not prone to scratching, cracking, or yellowing due to sun exposure. Robbins heat-seals glass

into glass window assemblies using the same equipment and techniques as Ford and other OEM convertible manufacturers. They do not use inferior methods that produce weak bonds, such as gluing them with silicon. All of our tops feature: Assembled header-bow bulb seal, specially treated vinyl to resist mildew, 3 year pro-rated warranty, coated vinyl for extra waterproofing, factory original pinpoint grain, heavy duty YKK nylon zipper, includes wire-on feature strip with stainless tips and screws, and meets motor vehicle fire retardant requirements. Stock colors are black and white, however we can special order Tan, Dark Blue, Brown, and Saddle. Special Order colors are non-returnable and have a \$30 upcharge. 1964-70 rear windows feature Robbins patented "Flex-Hinge" folding seam. 1971-73 are solid glass. 1964-66 must use convertible well liner part number WL-FM-67-BK. Glass rear window and top are packaged in a single box for reduced shipping cost.

64-66 Black	CSZZ-7652701-BR
64-66 White	CSZZ-7652701-WR
67-68 Black	C7ZZ-7652701-BR
67-68 White	C7ZZ-7652701-WR
69-70 Black	C9ZZ-7652701-BR
69-70 White	C9ZZ-7652701-WR
71-73 Black	D1ZZ-7652701-BR
71-73 White	D1ZZ-7652701-WR

**CONVERTIBLE TOP WITH GLASS BACK WINDOW**



Glass rear windows greatly enhance rear visibility. They are not prone to scratching, cracking or yellowing due to exposure to the

sun. 1964 - 1970 rear windows have a visible urethane folding seam. 1971 - 1973 are solid glass. 1964 - 1966 must use 67 - 70 convertible well liner. 1964 - 1970 folding seam carries an 18 month warranty against splitting or separation. Glass rear window and top are now packaged in 1 box to save on shipping cost.

**Convertible Top With Glass Back Window**

64-66 Black	CSZZ-7652701-PB
64-66 White	CSZZ-7652701-PW
67-68 Black	C7ZZ-7652701-PB
67-68 White	C7ZZ-7652701-PW

**Convertible Top With Glass Back Window**

69-70 Black	C9ZZ-7652701-PB
69-70 White	C9ZZ-7652701-PW
71-73 Black	D1ZZ-7652701-PB
71-73 White	D1ZZ-7652701-PW

**CONVERTIBLE TOP WITH PLASTIC BACK WINDOW**



Scott Drake tops are made from premium-grade 38 ounce material. Rear windows are included. Stocked in Black or

White, however we can special order Tan, Dark Blue, Maroon, Red, Green, Brown, Saddle and Gold. When quality matters, use the best! Special order colors are non-returnable and have a \$25 upcharge. All of our tops feature: Assembled front edge bulb seal, Pre-shrunk for a better fit, Specially treated vinyl to resist mildew, 5 year pro-rated guarantee against cracking, peeling, separating and excess fading. Coated vinyl for extra waterproofing, Factory original pinpoint grain, Heavy duty nylon easy glide zipper, Includes wire-on, stainless tips and stainless screws, Meets motor vehicle fire retardant requirements.

**Convertible Top With Plastic Back Window**

64-66 Black	CSZZ-7652700-PB
64-66 White	CSZZ-7652700-PW
67-68 Black	C7ZZ-7652700-PB
67-68 White	C7ZZ-7652700-PW
69-70 Black	C9ZZ-7652700-PB
69-70 White	C9ZZ-7652700-PW
71-73 Black	D1ZZ-7652700-PB
71-73 White	D1ZZ-7652700-PW

**WEATHER SEALS**

**CONVERTIBLE PILLAR SEAL**

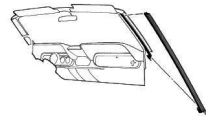

Superior quality E.P.D.M. sponge rubber with transfer molded ends.

**Convertible Pillar Seal**

64-68 Right and left hand	CSZZ-7602626/7D
69-70 Right hand	C9ZZ-7602626-A
69-70 Left hand	C9ZZ-7602627-A
71-73 Right and left hand	D1ZZ-7602626/7A

**CONVERTIBLE TOP HEADER TO**

**WINDSHIELD SEAL**



We offer this separately, for customers wanting to replace header only. Same quality as our complete kit.

**Convertible Top Header To Windshield Seal**

64-68	CSZZ-7653986-H
71-73	D1ZZ-7651325-A

**CONVERTIBLE TOP SEAL KIT**

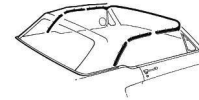

The smart choice for the informed Mustang enthusiast. Our kit is the best, guaranteed! Don't be fooled by poor quality imitations.

Comes with installation instructions. Note: Hardware not included. See kits 379361-SK & 351320-SK.

**Convertible Top Seal Kit**

64-68	CSZZ-7653986-K
69-70	C9ZZ-7653986-K
71-73	D1ZZ-7653986-K

**CONVERTIBLE TOP SEAL TUBE NUT SET**

A very special hex tube nut that we tooled. Zinc plated.



**Convertible Top Seal Tube Nut Set**

64-68 Set of 16	379361-SK
-----------------	-----------

**CONVERTIBLE TOP SEAL WASHER SET**

Exact copy, not an off the shelf generic washer. Washer is exact size and thickness.



**Convertible Top Seal Washer Set**

64-68 Set of 16	351320-SK
-----------------	-----------

**WEATHERSTRIP ADHESIVE**

Supplied in five ounce tubes. From 3M.



**Weatherstrip Adhesive**

64-73 Yellow, not for EPDM rubber	3M-8001
64-73 Black, not for EPDM rubber	3M-8008
64-73 Black, for EPDM rubber	3M-8011

**WELL LINERS**

Convertible

**WE PROUDLY FEATURE AUTHENTIC MUSTANG REPRODUCTIONS FROM SCOTT DRAKE ENTERPRISES!**





**WELL LINER**

Our well liners fit correctly. Made of heavy duty, textured vinyl. NOTE: Customers who have a 1964-1966 glass rear

window will need to use a 1967-1970 well liner.

**Well Liner**

64-66 Black .....	WL-FM-65-BK
64-66 White .....	WL-FM-65-WT
67-68 Black .....	WL-FM-67-BK
67-68 White .....	WL-FM-67-WT
69-70 Black .....	WL-FM-69-BK
69-70 White .....	WL-FM-69-WT
71-73 Black .....	WL-FM-71-BK
71-73 White .....	WL-FM-71-WT

**WELL LINER MOUNTING SET**

An 11 pc. set of flat/ phillips head screws to attach the well liner on convertibles.

**Well Liner Mounting Set**

64-68 .....	377948-SMK
-------------	------------

**WELL LINER TENSIONING SPRING**

Keeps the convertible well liner taut.

**Well Liner Tensioning Spring**

64-66 Long version .....	CODB-6461883-B
64-66 Short version .....	CODB-6461883-C

**COOLING SYSTEM****COOLANT CIRCULATION****DATE STAMPED RADIATOR AND HEATER HOSE CLAMP SET**

A must for any show, Scott Drake Radiator Hose Clamp Sets, with stamped date codes! These galvanized hose clamps are an authentic reproduction, each clamp is stamped with the correct date code. Sold in a convenient set of 10. These are Wittek concours correct.

64-65 6 Cyl, Stmpd w/"2/64" .....	C5ZZ8287-6 2-64
-----------------------------------	-----------------

64-65 V8, Stmpd w/"2/64" .....	C5ZZ8287-8 2-64
65-66 6 Cyl, Stmpd w/"2/65" .....	C5ZZ8287-6 2-65
65-66 V8, Stmpd w/"2/65" .....	C5ZZ8287-8 2-65
67-68 6 Cyl, Stmpd w/"4/66" .....	C5ZZ8287-6 4-66
67-68 5m-blck, Stpd w/"4/66" .....	C5ZZ8287-8 4-66

**NON-DATED RADIATOR AND HEATER HOSE CLAMP SET**

Original type post style clamps for big blocks.

**Radiator And Heater Hose Clamp Set, Non-Dated**

67-70 390, 428 .....	C5ZZ-8287-CK
----------------------	--------------

**RADIATOR COOLANT FILTER**

This filter is designed to be installed in the upper radiator hose. Installation of the "Full Flow" filter will stop radiator and heater core clogging due to rubber from hoses, foreign particles and rust scale. Filter is transparent and can easily be cleaned. Also available in a high performance brass version.

**Radiator Coolant Filter**

64-73: 8 cylinder, high performance, brass  
ACC-BCF



64-73: 6 cylinder, transparent  
ACC-GANO-6



64-73: 6 cylinder, high performance, brass  
ACC-GANO-6B



64-73: 8 cylinder, transparent  
ACC-GANO-8



64-73: 8 cylinder, aluminum  
ACC-GANO-8A



64-73: Standard  
ACC-GANO-HTR

**CONCOURS RADIATOR HOSE SET**

These are the best concours radiator hoses on the market. New improved stamping

will not come off even when in contact with antifreeze. All have imprints that are very crisp and authentic. Each imprint is concours correct for the specific application year. Represented by an oval FoMoCo, rectangle FoMoCo, Autolite logo or Motorcraft.

**Radiator Hose Set, Concours**

64-65 260, 289 and 289 high performance * .....	C4ZE-8260/86-A
---	----------------

64-70 170 and 200 * .....	C4ZE-8260/86-B
66 289 and 289 high performance * .....	C6ZE-8260/86-B

67 390, 427 and 428 * .....	C60E-8260/86-A
67 289 and 289 high performance * .....	C7ZE-8260/86-A

68 390, 427, 428 and 428 Cobra Jet * .....	C8ZE-8260/86-C
68 289 and 302 .....	C8ZE-8260/86-E

**GENERIC RADIATOR HOSE SET**

Same quality as our concours radiator hose sets, but without logos and part numbers. Great for daily drivers.

**Radiator Hose Set, Generic**

64-68 Small block .....	C4ZE-8260/86-G
-------------------------	----------------

**SILICONE RADIATOR HOSE SET**

Black silicone radiator hose set, includes bypass hose. Nylon reinforced lower hose has stainless steel spring. Silicone lasts longer and has a higher burst strength.

**Radiator Hose Set, Silicone**

64-68 .....	C5ZE-8260/86-BK
-------------	-----------------

**CONCOURS RADIATOR HOSE SET WITH WIRE CLAMPS**

These are the best concours radiator hoses on the market. New improved stamping

will not come off even when in contact with antifreeze. All have imprints that are very crisp and authentic. Each imprint is concours correct for the specific application year. Represented by an oval FoMoCo, rectangle FoMoCo, Autolite logo or Motorcraft. All

feature wire clamps stapled to hoses.

**Radiator Hose Set with Wire Clamps, Concours**

- 68 390, 427, 428 and 428 Cobra Jet\* .....  
C8ZE-8B273/4-D
- 69 302, Boss 302 and 351W\* .....  
C9ZE-8B273/7-B
- 69 302, 351W 20"\* ..... C9ZE-8B273/7-C
- 69-70 390,428 and 428 Cobra jet\* .....  
C9AE-8B273/4-E
- 69-70 Boss 429 (upper only)\* .C9AE-8B273/4-F
- 69-70 250 6 cylinder\* ..... C9ZE-8B273/7-A
- 70 302, Boss 302 and 351W\* .....  
D0ZE-8B273/4-B
- 70 351 Cleveland\* ..... D0ZE-8B273/4-C
- 71 302\* ..... D1AE-8B273/4-A
- 71 351 Cleveland\* ..... D1AE-8B273/4-DA
- 71 429\* ..... D10E-8B273/4-BA
- 71 250 6 cylinder\* ..... D1ZE-8B273/4-AA
- 72-73 302\* ..... D2AE-8B273/4-A
- 72-73 351 Cleveland\* ..... D2AE-8B273/4-DA

**WATER BYPASS HOSE**

\*  By-pass hose with original Ford/ Motorcraft markings.

**Water Bypass Hose**

-  64-66: FoMoCo logo\*  
C2DZ-8597-A
-  67-71: Autolite logo\*  
C70Z-8597-A
-  69-71: Autolite logo, dual diameter\*  
C90E-8597-D
-  72-73: Motorcraft logo, dual diameter\*  
D20E-8597-D

**WATER PUMP**



These all new pumps are the most logical way to end water pump problems. Gaskets are included with each pump.

**Water Pump**

- 64-65 260,289 cast aluminum .... C5AZ-8501-K
- 66-69 Small block, cast iron ..... C50Z-8501-H
- 67-70 390, 427, 428 Cobra Jet .... C8AZ-8501-A
- 70-73 351 Cleveland ..... D0AZ-8501-E
- 70-73 302, Boss 302, 351W ..... D00Z-8501-A

**HI-PO WATER PUMP**



Built to cool better and last longer than any other pump built today. Features high efficiency impeller and NASCAR roller type

bearing. Both small blocks are aluminum units.

- Water Pump, Hi-Po**
- 63-66 Hi-Flow ..... C30Z-8501-HPA
  - 66-69 Small block, high performance, high flow. Replaces cast iron water pump ..... C50Z-8501-HPA
  - 67-70 Big block, high performance, high flow, iron ..... C8AZ-8501-HPA

**WATER PUMP BOLT KIT**



These bolts are exact copies. Feature correct head markings and lengths. Includes detailed instructions for the position of each

bolt.

- Water Pump Bolt Kit**
- 64 260, 289, with a/c ..... WPB-C20E-487
  - 64 260, 289, with a/c ..... WPB-C20E-491
  - 64-70 170,200 ..... WPB-C0DE-498
  - 65 289, with a/c ..... WPB-C20E-388
  - 65 289, with a/c ..... WPB-C50E-492
  - 66 289, 302, with a/c ..... WPB-C60E-242
  - 66-68 289, 302, with a/c ..... WPB-C60E-304
  - 67 289, with a/c ..... WPB-C70E-249
  - 67-70 390, 428 ..... WPB-B8AE-497
  - 68 289, 302, with a/c ..... WPB-C80E-305
  - 69 302, 351W, Boss 302, without air conditioning ..... WPB-C90E-307
  - 69 302, 351W, with a/c ..... WPB-C90E-308
  - 69-73 250 ..... WPB-C9DE-558
  - 70-73 302, 351W, Boss 302 ..... WPB-D00E-306
  - 70-73 351 Cleveland ..... WPB-D00E-309
  - 71 429 ..... WPB-C8SE-1499

**FAN SHROUD AND FAN**

**CLUTCH FAN BOLT**

4 piece set.



**Clutch Fan Bolt**

- 66-73 ..... C50E-1804

**CAUTION FAN DECAL**



Decal placed on the fan shroud to remind you to keep all ten of your fingers. Great idea for all years.

**Decal, Caution Fan**

- 68-69 ..... DF-31

**ELECTRIC FAN AND SHROUD KIT**



This kit increases cooling capabilities especially at idle and low RPM. Tired of overheating in traffic? This easy to install kit

is not a universal kit. It is made specifically to fit all 259 radiators. No extra holes to drill. Also improves horsepower and economy. Instructions included.

**Electric Fan And Shroud Kit**

- 64-66 ..... C3DZ-8146/8600

**FAN BLADE**



17 inch diameter fan improves cooling. Painted black. C5ZZ and C6ZZ are not compatible with clutch fan assembly.

**Fan Blade**

- 64-73 4 blade, HiPo ..... C5ZZ-8600-HP
- 64-73 6 Blade ..... C6ZZ-8600-C
- 65-70 5 Blade ..... C5ZZ-8600-C
- 68-69 390 Concours ..... C80E-8600-B
- 69-70 428 CJ, Concours ..... C9ZE-8600-E

**FAN SHROUD**



An absolute must to keep you car running cool and efficient in Original steel, ABS or fiberglass.

**Fan Shroud**

- 64-66 Small block, original steel C3DZ-8146-DR
- 64-66 High performance, ABS plastic, 3-1/2" wide ..... C3DZ-8146-3
- 64-66 High performance, fiberglass 3 1/2" wide  
C3DZ-8146-3F
- 67 Big block, fiberglass, 24" ... C7ZZ-8146-A
- 68-70 Big block, 24", will fit 67 .... C8ZZ-8146-A
- 68-69 Small block with air conditioning, 24" ...  
C90Z-8146-A
- 67-69 Small block without air conditioning, 20"  
C9Z-8146-BR
- 70 302 and 351 with air conditioning. 24" ..  
D0ZZ-8146-A
- 70 302 and 351 without air conditioning.  
20" ..... D0ZZ-8146-B

Cooling

**WE PROUDLY FEATURE AUTHENTIC MUSTANG REPRODUCTIONS FROM SCOTT DRAKE ENTERPRISES!**



### Fan Shroud

71-73 302 and 351 with air conditioning .....  
D1ZZ-8146

### FAN SHROUD BRACKET

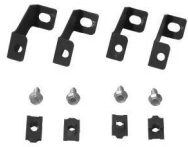

Now made by Scott Drake. Steel brackets with a dull black finish. Mounting hardware included.

### Fan Shroud Bracket

64-66 2 core ..... C3DZ-8149-2  
64-66 3 core ..... C3DZ-8149-3  
64-66 4 core ..... C3DZ-8149-4

### FAN SPACER



Our fan spacers are available in several different finishes and styles.

### Fan Spacer

64-73 Natural finish, 2.25" ..... C4AZ-8546-A  
64-73 Polished, 2.25" ..... C4AZ-8546-P  
65-66 Concours OE, HiPo 289, w/logo, 2.12" \* ..  
C3OZ-8546-A

## RADIATOR CAPS

### RADIATOR CAP



These concours quality caps are made in America and bear all the original markings. O.E.M. details include original letter style, S.M.C.O. and Autolite. Pound rating is stamped on cap.

### Radiator Cap

64-66 SMCO CON Radiator cap (zinc plated) .....  
C5ZZ-8100-A  
64-66 SMCO CON Radiator cap (chrome plated)  
C5ZZ-8100-AC  
67-71 Autolite Radiator cap (zinc plated) .....  
C7ZZ-8100-A  
67-71 Autolite Radiator cap (chrome plated) ...  
C7ZZ-8100-AC  
65-73 Motorcraft, 2-ear design, limited supply\*  
C9ZZ-8100-A

### BILLET RADIATOR CAP



Another custom billet aluminum product from Scott Drake. We made a clear anodized aluminum top and mated it with a stock

### Motorcraft cap.

Radiator Cap, Billet  
64-73 Billet ..... B-8100

### RADIATOR CAP WITH ELECTROLYSIS PROTECTION



A special radiator cap that includes a sacrificial magnesium anode that protects aluminum and other soft material engine

components from electrolysis. Electrolytic Metal Erosion (EME) is slowly destroying your engine components. EME attacks timing chain covers, radiators, heater cores, intake manifolds, freeze plugs, head gaskets, thermostat housings even cylinder heads causing premature failures. By allowing EME to attack the sacrificial anode, the radiator cap protects your engine while driving or in storage.

### Radiator Cap With Electrolysis Protection

64-73 With sacrificial anode ... C5ZZ-8100-RC-E

## RADIATOR MOUNTING

### RADIATOR INSULATOR

Made from E.P.D.M. rubber, molded just like the original.



### Radiator Insulator

67 Lower ..... C3AZ-8125-A  
68-70 Lower ..... C8ZZ-8125-A  
67-68 Upper, 2 row ..... C7OZ-8124-A  
67-68 Upper, 3 row ..... C7OZ-8124-A3  
67-68 Upper, 4 row ..... C7OZ-8124-A4

### RADIATOR MOUNTING BRACKET

These Brackets are made by Scott Drake from stamped steel just like the original, and built following Ford prints for an exact fit. Available in correct OEM Black (like the original), or in a highly-polished stainless steel for customers looking for a little more flash under the hood!

### Radiator Mounting Bracket



67: Lower, OEM black, fits original radiators only - for aftermarket radiators use C8ZZ-8052-A  
C7ZZ-8052-A



68-70: Lower, OEM black, will fit 1967  
C8ZZ-8052-A

### Radiator Mounting Bracket



67-68: Upper, OEM black  
C7ZZ-8A193-A



67-68: Upper, polished stainless steel  
C7ZZ-8A193-S



69-70: Upper, OEM black  
C9ZZ-8A193-A



69-70: Upper, polished stainless steel  
C9ZZ-8A193-S

### RADIATOR MOUNTING KIT



Black oxide finish to prevent rust. Kit includes four washer bolts and four "J" nuts. (Not for saddle mount radiators).

### Radiator Mounting Kit

64-68 ..... C5ZZ-8005-MK

## RADIATORS

### 2 CORE, HIGH PERFORMANCE, ALUMINUM RADIATOR

New by Drake! These 2-row aluminum radiators feature extra large 1" tubes to equal 4 row efficiency, but with 5-7 lbs less weight. Benefit from improved performance through modern technology.

### Radiator, 2 Core, High Performance, Aluminum



64-66: 2 Row, 170, 200 6 cyl w/ trans cooler  
251-2AL



64-66: 260, 289 V8, w/ trans cooler  
259-2AL



64-66: Late Model 5.0, manual trans.  
259-2AL-LM



64-66: Manual trans  
259-2AL-MT

## RADIATOR SPECIFICATION CHART

**NOTE: If your 1967-70 Mustang originally came with a bolt on radiator, and you are purchasing a saddle mount radiator, you will need to buy the proper mounting brackets.**

**\* 1967 Cars: Must use 1968 lower saddle mount brackets which are wider.**

Radiator	Height / Width	Inlet	Outlet	Mount
251 2-3-4 Row	16 3/8" x 17 1/4"	1 1/4" diameter top right	1 1/4" diameter bottom left	Bolt on
259 3-4 Row	16 3/8" x 17 1/4"	1 1/2" diameter top right	1 3/4" diameter bottom right	Bolt on
329 2-3 Row	16 3/8" x 20 1/4"	1 1/4" diameter top right	1 1/4" diameter bottom left	Bolt on
338 2-3-4 Row	16" x 24 1/8"	1 1/2" diameter top right	1 3/4" diameter bottom right	Saddle
339 2-3-4 Row	16 3/8" x 20 1/4"	1 1/2" diameter top right	1 3/4" diameter bottom left	Bolt on
340 2-3-4 Row	16 3/8" x 20 1/4"	1 1/2" diameter top right	1 3/4" diameter bottom right	Bolt on
379 3-4 Row	16" x 24 1/8"	1 1/2" diameter top right	1 3/4" diameter bottom left	Saddle
381 3-4 Row	17 3/4" x 26"	1 1/2" diameter top right	1 1/2" - 1 3/4" diameter bottom left	Saddle
556 3-4 Row	17" x 24 1/2"	1 1/2" diameter top right	1 1/2" diameter bottom left	Saddle

### Radiator, 2 Core, High Performance, Aluminum



67-69: 289, 302, 351W, With trans cooler 20"  
340-2AL



67-70: 67-69: Late Model 5.0 70: 302 & 351C 20"  
339-2AL



68-70: 390, 428 (also fits '70 302, 351), w/ trans cooler, 24"  
379-2AL

### 3 CORE RADIATOR



Full 2 year warranty (Limited to repair or replacement), molded foam for optimum shipping protection, all radiators are 100%

pressure tested by manufacturer, meets or exceeds original equipment specifications, long lasting satin black finish, all copper/brass core construction which resists corrosion, state of the art multi-louvered fin design which delivers maximum air flow & cooling. Note: Warranty does not include removal/ installation labor or return shipping. Drain valve sold separately. Made in the U.S.A.

#### Radiator, 3 Core

64-66 170, 200 6 cylinder .....	251-3
64-66 260, 289 .....	259-3
64-66 V8 Imported.....	259-3N
67-69 200 6 cylinder .....	329-3
67-69 289, 302, 351 with air conditioning, 24", Requires 68-70 lower mounting brackets	338-3
67-69 289, 302, 351 without air conditioning, 20" .....	340-3
67-70 67-70: 390, 428 70: 302, 351 w/ AC, 24"	379-3
69-70 250 6 cylinder .....	339-3

### Radiator, 3 Core

70 302, 351 without air conditioning, 20" ...	340-3C
71-73 302, 351, 429 .....	381-3

### 3 CORE, HI-FLOW RADIATOR



This radiator comes with a full 1 year warranty (limited to repair or replacement only). Brass/copper construction. Fins designed for maximum cooling. Large 1/2 inch tube diameter increases cooling flow and prevents plugging. Automatic transmission cooler included.

#### Radiator, 3 Core, Hi-Flow

64-66 6 cylinder .....	251-3HF
64-66 V8 .....	259-3HF
67-69 200 6 cylinder .....	329-3HF
67-69 Small block without air conditioning .....	340-3HF
67-70 24" .....	338-3HF
69-70 250, 302 .....	339-3HF

### 4 CORE RADIATOR



Full 2 year warranty (Limited to repair or replacement), molded foam for optimum shipping protection, all radiators are 100% pressure tested by manufacturer, meets or exceeds original equipment specifications, long lasting satin black finish, all copper/brass core construction which resists corrosion, state of the art multi-louvered fin design which delivers maximum air flow & cooling. Note: Warranty does not include removal/ installation labor or return shipping. Drain valve sold separately. Made in the U.S.A.

#### Radiator, 4 Core

64-66 170, 200 flat top design) .....	251-4
64-66 (flat top design) 260, 289 .....	259-4
67-69 289, 302, and 351 with air conditioning .	338-4

### Radiator, 4 Core

67-69 (flat top design) 289, 302, 351 without air conditioning .....	340-4
68-70 68-70: 390, 428 70: also 302, 351 w/ AC	379-4
69-70 (flat top design) 250, 302, 351 without air conditioning .....	339-4
71-73 302, 351, 429 .....	381-4

### RADIATOR DRAIN VALVE



These are O.E.M. replacements and will not fit most after market radiators.

#### Radiator Drain Valve

64-73 .....	8A-8115
-------------	---------

## TEMPERATURE CONTROL

### THERMOSTAT

Quality U.S.A. made.



#### Thermostat

64-73 190 degree, all engines .....	RT-1120
64-73 160 degree, 6 cylinder and small block ..	RT-350
64-73 180 degree, 6 cylinder and small block ..	RT-351

### THERMOSTAT HOUSING



Super quality aluminum casting, which is made in the U.S.A. Exact copy of original, including part numbers. Also

**WE PROUDLY FEATURE AUTHENTIC MUSTANG REPRODUCTIONS FROM SCOTT DRAKE ENTERPRISES!**



available in chrome. Aftermarket.

**Thermostat Housing**

- 64-73 289 and 302 without smog, original cast aluminum style ..... C50E-8592-A
- 64-73 Small block, chrome ..... C5ZZ-8592-C
- 68-70 Big block ..... C8AE-8592-B
- 70-73 351 Cleveland, chrome ..... D0ZZ-8592-C

**THERMOSTAT HOUSING BOLT**

Correct headstamp.  
Sold in pairs.



**Thermostat Housing Bolt**

- 64-70 6 cylinder ..... WNM-CODE-504
- 64-73 260, 289, 351W ..... WNM-C20E-506

**THERMOSTAT HOUSING GASKET**

Thermostat Housing Gasket BY FEL-PRO.



**Thermostat Housing Gasket**

- 60-73 6 cylinder and small block . C5AZ-8255-A
- 67-70 390, 428 ..... C7ZZ-8255-D
- 70-73 351 Cleveland ..... C9ZZ-8255-A

**WATER TEMPERATURE SENDING UNIT**

Brass sensor that screws into intake manifold and activates temperature gauge in dash.  
**Water Temperature Sending Unit**



- 64-66: All engines before 9/1/65  
C3AZ-10884-A



- 66-71: 200, 289, 302 and 390 after 9/1/65  
C6DZ-10884-B



- 69-73: Without tach  
C9DZ-10884-A

**TRANSMISSION OIL COOLER FITTING**

Brass fitting which screws into radiator oil cooler.



**Transmission Oil Cooler Fitting**

- 67-73 ..... MOCF01

**DECALS & STRIPING**

**CHASSIS, BODY AND EXTERIOR DECALS**

**3" MUSTANG DECAL**



A brightly colored three inch round decal featuring the famous running horse.



- Decal, 3" Mustang**  
64-73 \* ..... DF-266

**FENDER DECAL**



Identical to the factory markings.

**Decal, Fender**

**BOSS 429**

- 69-70: BOSS 429, black\*  
DF-225

**BOSS 429**

- 69-70: BOSS 429, white\*  
DF-226

**BOSS 351 MUSTANG**

- 71: BOSS 351, black\*  
DF-505

**BOSS 351 MUSTANG**

- 71: BOSS 351, argent\*  
DF-506

**mach 1**

- 71-72: Mach 1, black\*  
DF-675

**mach 1**

- 71-72: Mach 1, argent\*  
DF-676

**FORD BLUE OVAL DECAL**

The infamous Ford blue oval on a decal.



**Decal, Ford Blue Oval**

- 64-73 3 1/2" oval\* ..... DF-361
- 64-73 6 1/2" oval\* ..... DF-362

**Decal, Ford Blue Oval**

- 64-73 9 1/2" oval\* ..... DF-363
- 64-73 17" oval\* ..... DF-364

**FORD DRAG TEAM DECAL**



Bold block letters proclaiming this car as a member of the Ford Factory



Drag Team.

**Decal, Ford Drag Team**

- 64-73 5" Rectangle\* ..... DZ-115
- 64-73 8" Rectangle\* ..... DZ-116

**GENUINE PARTS OVAL DECAL**

Copy of vintage logo.



**Decal, Genuine Parts Oval**

- 64-73 3" blue oval\* ..... DF-531

**KONI DECAL**

The timeless Koni wings on a sticker.



**Decal, Koni**

- 64-73 ..... DZ-112

**OUTSIDE TRUNK DECAL**



**Decal, Outside Trunk**

- BOSS 351** 71: Boss 351, black\*  
DF-507

- BOSS 351** 71: Boss 351, argent\*  
DF-508

- mach 1** 71-72: Mach 1, black\*  
DF-677

- mach 1** 71-72: Mach 1, argent\*  
DF-678

## PAINT OK DECAL

These were used to confirm that the vehicles paint and trim had passed inspection.  
Decal, Paint OK



64-73: Red "P"  
DF-1157

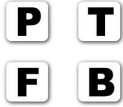

69-71  
DF-460

## RAM AIR HOOD DECAL

RAM AIR letters.

### 351 RAM AIR

#### Decal, Ram Air Hood

70	351, black	DF-383
70	351, white	DF-576
70	428, black	DF-516
70	428, white	DF-583
71	429 RAM AIR, black	DF-420
71	429 RAM AIR, argent	DF-419
71-72	RAM AIR, black	DF-385
71-72	RAM AIR, argent	DF-384
71-72	351 RAM AIR, black	DF-387
71-72	351 RAM AIR, argent	DF-386

## RUNNING HORSE DECAL



Running Bar Horse Decal. Red, white, and blue bars with a silver horse.

#### Decal, Running Horse

64-73	5", left hand*	DZ-253
64-73	5", right hand*	DZ-254
64-73	7", left hand*	DZ-255
64-73	7", right hand*	DZ-256

## SHELBY DECAL



#### Decal, Shelby



64-73: 3" square with CS logo<sup>®</sup>  
DF-501



65-70: 2 1/4" round with Tiffany snake, for shock absorber<sup>®</sup>  
DF-635

#### Decal, Shelby



65-70: 10" round, for Shelby hi-performance equipment<sup>®</sup>  
DZ-110



65-70: 1 5/8" x 7 1/4" with CS Shelby logo<sup>®</sup>  
DZ-70

## SHOCKS DECAL

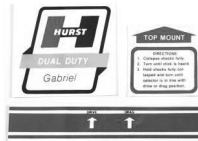

Replicas of the decals that identified the shocks on the factory drag race Mustangs of 1969/70.

#### Decal, Shocks

69-70 Hurst shock decal set ..... DZ-75

## U.S.A. BODY SHIELD DECAL



This decal went on the rear of the quarter panel of the 1972 Olympic Sprint convertible of which only fifty were

#### produced

#### Decal, U.S.A. Body Shield

72 ..... DF-388

## WHEEL CENTER DECAL



#### Decal, Wheel Center



65-67: Wire wheel, blue<sup>\*</sup>  
DF-533



66: Shelby Hertz car club  
DF-587



66: Shelby 5 spoke wheel center<sup>®</sup>  
DF-588

## DECAL KITS

### DECAL KIT



Great Detailing Aid. These Kits include all the common decals. Air Cleaner & AC

Decal are not included.

#### Decal Kit

64	*	.....	DK-24
65	*	.....	DK-25
66	*	.....	DK-26
67	*	.....	DK-27
68	*	.....	DK-28
69	*	.....	DK-29
70	*	.....	DK-30
71	*	.....	DK-31
72	*	.....	DK-32
73	*	.....	DK-33

## EMISSION DECALS

### EMISSIONS DECAL

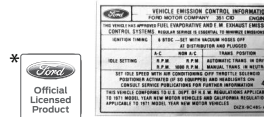

This decal shows that this vehicle complied with emission regulations.

#### Decal, Emissions

68	GT 500, GT 350*	DF-341
68-69	Small block, 2V*	DF-296
68-69	Big block, 4V*	DF-297
68-69	302, 351, 4V*	DF-562
69	GT 390, 4V*	DF-782
69-70	GT 500*	DF-174
69-70	GT 350*	DF-175
69-70	Boss 302*	DF-197
69-70	Boss 429*	DF-295
70	200 6 cylinder*	DF-311
70	Boss 302, late 1970*	DF-344
70	Boss 302, manual transmission*	DF-650
70	351, 4V*	DF-742
70	200 6 cylinder*	DF-772
71	Boss 351, manual transmission*	DF-455
71	351, 2V*	DF-554
71	429 Cobra Jet, 4V*	DF-555
71	351, 4V, manual transmission* ...	DF-582
71	200 6 cylinder*	DF-666
71	302, 2V*	DF-763
72	351 Cleveland, 2V*	DF-594
73	351 Cleveland, 4V*	DF-638
73	351 Cleveland, 2V, automatic transmission*	DF-640

Decals/Stripes

WE PROUDLY FEATURE AUTHENTIC MUSTANG REPRODUCTIONS FROM SCOTT DRAKE ENTERPRISES!



29

**Decal, Emissions**

73 302, 2V\* ..... DF-641

**ENGINE COMPARTMENT DECALS**

**AIR CLEANER DECAL**

Identical to the factory decal that designated engine and carburator size as well as



service instructions.

**Decal, Air Cleaner**

64	260 CID*	DF-45
64-65	Service*	DF-83
64-66	Vent	DF-350
64-67	289 High Performance*	DF-15
64-68	Air cleaner, 8 cylinder*	DF-160
64-68	Air cleaner, 6 cylinder*	DF-352
64-73	Front	DF-150
65	170 CID*	DF-95
65-66	289-2V*	DF-13
65-66	289-4V*	DF-14
65-68	200 CID*	DF-59
65-70	Ventra Flow	DF-477
66	200 CID Sprint*	DF-171
66	Part Number	DF-37
66-73	Service*	DF-149
67	Part Number	DF-261
67	Cobra*	DF-744
67-68	289-2V*	DF-104
67-68	289-4V*	DF-105
67-68	Sports Sprint	DF-246
67-68	390 High Performance*	DF-322
67-69	390 CID*	DF-53
67-69	390 4V, premium fuel*	DF-54
68	428-4V, premium fuel*	DF-221
68	427-4V, premium fuel*	DF-316
68	427 4V High Performance*	DF-324
68-69	302 High Performance*	DF-321
68-69	250 CID*	DF-443
68-69	302-2V*	DF-60
68-69	302-4V, premium fuel*	DF-61
69	Boss 302*	DF-162
69	351-2V*	DF-62
69	351-4V, premium fuel*	DF-63
69	428*	DF-778
69-70	Cobra Jet Ram Air*	DF-178
69-70	351 Ram Air*	DF-179
69-70	428 Cobra Jet*	DF-379
70	250 CID*	DF-172
70-71	302 2V, regular fuel*	DF-182
70-71	302-4V, premium fuel*	DF-183
70-71	351-2V, regular fuel*	DF-184
70-71	351-4V, premium fuel*	DF-185
70-71	390-4V, premium fuel*	DF-479
71	429-4V, regular fuel*	DF-181

**Decal, Air Cleaner**

71	Boss 351*	DF-260
71	429 Cobra Jet*	DF-395
71	429-4V, premium fuel*	DF-451
71-73	351-2V, regular fuel*	DF-668
72	351 Cobra Jet*	DF-365
72	351 HO*	DF-553
72-73	302-4V, premium fuel*	DF-254
72-73	351-2V, regular fuel*	DF-255
72-73	351-4V, regular fuel*	DF-256
72-73	302-2V, regular fuel*	DF-584
72-73	250 1V*	DF-643

**AIR CONDITIONING DECAL**

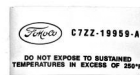

**Decal, Air Conditioning**

64-66	AC sight glass*	DF-1130
64-66	AC Dryer*	DF-550
64-70	AC aluminum tag*	DF-351
67-68	AC Dryer*	DF-153
67-70	AC clutch*	DF-548
69	AC Dryer*	DF-656
70	AC Dryer*	DF-549
71-73	AC charge mounts on radiator support*	DF-532

**AUTOLITE DECAL**

Various vintage Autolite decals.



DZ-122

**Decal, Autolite**

64-68	Air cleaner, 8 cylinder*	DF-160
64-68	Air cleaner, 6 cylinder*	DF-352
64-70	FL-1 oil filter*	DF-684
64-70	F-11 racing oil filter*	DF-783
64-72	Sta-ful battery tag*	DF-784
64-73	Autolite/Ford, 1/2" X 2 1/2" Rectangle*	DZ-120
64-73	5" GT-40 rectangle*	DZ-122
64-73	8" GT-40 rectangle*	DZ-123
64-73	Autolite spark plugs, 6.5" round*	DZ-4
64-73	Autolite spark plugs, 4" round*	DZ-5
67-70	Fuel filter*	DF-1123
68-75	Air Cleaner*	DF-325

**BATTERY DECAL**

This decal informed the buyer that the battery was checked and was certified to be OK.

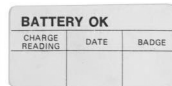

**Decal, Battery**

64 ..... DF-405

**Decal, Battery**

64-70 ..... DF-194

**CAUTION FAN DECAL**

Decal placed on the fan shroud to remind you to keep all ten of your fingers.



**Decal, Caution Fan**

68-69 ..... DF-31

**COIL DECAL**

Makes coil look more authentic.



**Decal, Coil**

64	*	DF-33
65-72	*	DF-224
72-73	*	DF-715

**COOLANT WARNING DECAL**

Decal supplied to inform owner of cooling system requirements.

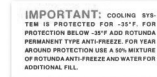

**Decal, Coolant Warning**

64-66 ..... DF-250

**DISC BRAKE MASTER CYLINDER DECAL**

Advised owner of the proper brake fluid for each vehicle.



**Decal, Disc Brake Master Cylinder**

66	.....	DF-331
67	.....	DF-332

**FORD 6000 MILE OR 6 MONTH LUBE DECAL**



**Decal, Ford 6000 Mile or 6 Month Lube**

64-73 \* ..... DF-746

### FUEL FILTER DECAL

A decal supplied with the fuel filter on all cars.



**Decal, Fuel Filter**  
64-66 \* ..... DF-280

### GENERATOR DECAL

This decal was on the generator to insure proper fitment.



**Decal, Generator**  
64 \* ..... DF-515

### MOTORCRAFT DECAL

Motorcraft GT 40 sticker with the famous Speeding racer.



**Decal, Motorcraft**  
64-73 6 1/4" x 5" \* ..... DZ-121

### OIL FILLER CAP DECAL

This decal was put on the oil cap to alert the owner about the recommended



type of oil to use.  
**Decal, Oil Filler Cap**  
64-66 \* ..... DF-164

### OIL FILTER DECAL

Decals to go on a regular oil filter to give the appearance of a vintage Ford filter.



**Decal, Oil Filter**  
64-67 Rotunda, red \* ..... DF-613  
64-67 6000 Mile Rotunda, gold \* ..... DF-647

### SERVICE SPECIFICATION DECAL

This sticker was used to alert the owner of regular service schedules.



**Decal, Service Specification**  
64 \* ..... DF-345  
65-66 \* ..... DF-20  
67-69 \* ..... DF-52

### Decal, Service Specification

70 \* ..... DF-346  
71 \* ..... DF-308

### STARTER DECAL

This decal was put on the starter to assure proper fitment.



**Decal, Starter**  
64 \* ..... DF-447

### VALVE COVER DECAL



**Decal, Valve Cover**  
64-73 Powered By Ford, chrome \* ..... DF-410  
64-73 Powered By Ford, white \* ..... DF-411  
65-67 289 Cobra \* ..... DF-373  
69-70 Boss 302 \* ..... DF-138  
69-70 Boss 429 \* ..... DF-176  
71 Boss 351 \* ..... DF-394

### VOLTAGE REGULATOR DECAL

This was put on each voltage regulator to inform that it was the correct part.



**Decal, Voltage Regulator**  
64-66 Warning, yellow ..... DF-347  
65-66 Autolite \* ..... DF-412  
65-70 Warning, red ..... DF-320  
67 Autolite \* ..... DF-348  
68-71 Autolite, high Performance \* ..... DF-464  
72-73 Motorcraft \* ..... DF-714

### ANTIFREEZE TAG

A tag attached to the radiator that explains service procedures.



**Tag, Antifreeze**  
64-66 Rotunda \* ..... DF-699  
64-70 FoMoCo \* ..... DF-120  
67-73 Ford \* ..... DF-700

## INTERIOR DECALS

### MUSTANG OIL SERVICE DECAL



These static cling service reminders feature authentic color logo design. Install on windshield or door jam, easily removed without any residue or harm to surface. Helpful reminder whether you change your oil yourself or have your mechanic do it. Gives your car that personalized touch of detail that others will envy. Packaged 6 per container in our new custom designed reclosable clear plastic clam shell.

**Decal, Mustang Oil Service**



64-73: Shelby logo<sup>®</sup>  
05-2

### RADIO REVERBERATION DECAL

A decal for the radio telling of reverb option.

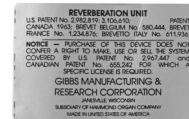

**Decal, Radio Reverberation**  
64-66 ..... DF-651

### SHELBY DASH DECAL

A nice reproduction of the decal that went on the dash.



COBRA JET GT 500

**Decal, Shelby Dash**  
69-70 GT 350<sup>®</sup> ..... DF-196  
69-70 GT 500<sup>®</sup> ..... DF-298

### SHELBY FOG LIGHT AND INTERIOR CONSOLE DECAL

Decal for fog light and interior light switch.



**Decal, Shelby Fog Light And Interior Console**  
69-70 ..... DF-173

### STEREO DOOR SPEAKER DECAL

Stereo script to go on speakers.



**Decal, Stereo Door Speaker**  
69-70 ..... DF-577

Decals/Stripes

**WE PROUDLY FEATURE AUTHENTIC MUSTANG REPRODUCTIONS FROM SCOTT DRAKE ENTERPRISES!**





**SUN VISOR SEAT BELT DECAL**

Shelby Sun Visor Seat Belt Decal and the small silver snake decal supplied on the buckle of Shelby seat belts.

**SEAT BELTS SHOULD BE WORN IN CONJUNCTION WITH SHOULDER HARNESS**

**Decal, Sun Visor Seat Belt**  
67-70 ..... DF-343

**TIRE PRESSURE DECAL**

A Ford licensed product, this decal gives loads of information about your cars

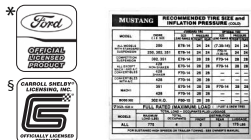

**original tires.**  
**Decal, Tire Pressure**  
65-66 For cars with "Red Ring" sidewalls \* .....  
DF-463

- 66 \* ..... DF-19
- 67-68 Shelby, high speed ..... DF-158
- 67-68 \* ..... DF-282
- 67-68 Shelby<sup>s</sup> ..... DF-586
- 68 Door\* ..... DF-283
- 69 Early 1969\* ..... DF-559
- 69 Late 1969\* ..... DF-376
- 69-70 Shelby, glove box<sup>s</sup> ..... DF-137
- 69-70 Glove box\* ..... DF-310
- 70 Door\* ..... DF-1004
- 70 Early 1970\* ..... DF-789
- 70 Late 1970\* ..... DF-147
- 71 \* ..... DF-377
- 72 \* ..... DF-380
- 73 \* ..... DF-378

**SHELBY SEAT BELT INSERT EMBLEM**

They are the most authentic and best looking emblems available.



**Emblem, Shelby Seat Belt Insert**



67: Shelby Cobra<sup>s</sup>  
S7MS-63611A73-A



68: Shelby Cobra, gold<sup>s</sup>  
S8MS-63611A73-A



69-70: Shelby<sup>s</sup>  
S9MS-63611A73-A

**SUN VISOR STARTING INSTRUCTION SLEEVE**

Instructions showing how to start your Mustang.



**Instruction Sleeve, Sun Visor Starting**  
64-70 \* ..... DF-170

**NEW CAR WINDOW PRICE STICKER**



**Price Sticker, New Car Window**

- 64 \* ..... DF-595
- 65 \* ..... DF-43
- 66 Shelby<sup>s</sup> ..... DF-123
- 66 \* ..... DF-25
- 67 \* ..... DF-124
- 67 GT 500<sup>s</sup> ..... DF-227
- 67 GT 350<sup>s</sup> ..... DF-228
- 68 Shelby<sup>s</sup> ..... DF-200
- 69 \* ..... DF-88
- 69-70 Shelby<sup>s</sup> ..... DF-328
- 70 \* ..... DF-240
- 71 \* ..... DF-87
- 72 \* ..... DF-264
- 73 \* ..... DF-243

**3 SPEED MANUAL TRANSMISSION INSTRUCTION TAG**

A tag that explains shifting procedure on hills or traffic. For 3 speed cars.

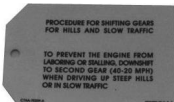

**Tag, 3 Speed Manual Transmission Instruction**  
67-68 ..... DF-649

**CAUTION DRIVEN INSTRUCTION TAG**

This decal was supplied to instruct the owner that the car should be driven regularly to keep components working properly.



**Tag, Caution Driven Instruction**  
64-69 ..... DF-208

**DISC BRAKE WARNING TAG**

A warning tag that shows proper use and care of disc brakes.



**Tag, Disc Brake Warning**  
65 ..... DF-729

**HEATER INSTRUCTION TAG**

A paper tag that was hanging from the heater knob when you bought the car.

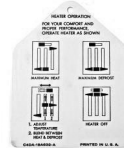

**Tag, Heater Instruction**  
64 ..... DF-51  
65-66 ..... DF-564

**NOVELTY WARNING TAG**

A fun tag for your Shelby GT that warns of the consequences of driving near pretty girls.



**Tag, Novelty Warning**  
65-70 Shelby GT 350 ..... DF-625  
67-70 Shelby GT 500 ..... DF-626

**SEAT BELT RETRACTOR TAG**

A tag supplied with cars to explain the proper way to use the retractable seat belts.

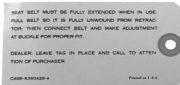

**Tag, Seat Belt Retractor**  
64-67 ..... DF-305

**WINDSHIELD WASHER ADJUSTER TAG**

**Tag, Windshield Washer Adjuster**  
65-66 ..... DF-444



Decals/Stripes

## PRE-DELIVERY DECALS

### SHELBY PRE-DELIVERY SHEET



This sheet was given to the buyer at the dealership to show that his new Shelby had

gone through a series of checks and tests.

#### Pre-Delivery Sheet, Shelby

66	GT 350 <sup>S</sup>	DF-660
67	GT 350 <sup>S</sup>	DF-661
68	<sup>S</sup>	DF-476
69	<sup>S</sup>	DF-663
70	<sup>S</sup>	DF-664

## STRIPES

### GT STENCIL KIT



Stencil kit or patterns to install GT stripe kit, Mustang letters and Mustang emblems.

#### Stencil Kit, GT

65-66	.....	MSK001
-------	-------	--------

### BOSS 302 STRIPE KIT

Excellent quality automotive grade vinyls. All of our stripe kits have special agents added for U.V. protection. Mill thicknesses are equal to the original O.E. stripes

#### Stripe Kit, Boss 302

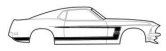

69: Black\*  
C9ZZ-6320000-V



69: White\*  
C9ZZ-6320000-W



70: Black\*  
D0ZZ-6320000-C

### C STRIPE KIT



Our quality reproduction stripe kits come with installation instructions. Excellent quality automotive grade vinyls. All of our

stripe kits have special agents added for U.V.

protection. Mill thicknesses are equal to the original O.E. stripes. Individually boxed.

#### Stripe Kit, C

68	Black	.....	C8ZZ-6520000-A
68	White	.....	C8ZZ-6520000-B
68	Red	.....	C8ZZ-6520000-C
68	Blue	.....	C8ZZ-6520000-D
68	Gold	.....	C8ZZ-6520000-E
68	Reflective Gold	.....	C8ZZ-6520000-R

### CALIFORNIA SPECIAL STRIPE KIT



Our quality reproduction stripe kits come with installation instructions. Individually

boxed.

#### Stripe Kit, California Special

68	Black*	.....	C8ZX-16224-A
68	White*	.....	C8ZX-16224-B
68	Red*	.....	C8ZX-16224-C
68	Blue*	.....	C8ZX-16224-D
68	Gold*	.....	C8ZX-16224-G

### GT STRIPE KIT



Our quality reproduction stripe kits come with installation instructions. Excellent quality automotive grade vinyls. All of our

stripe kits have special agents added for U.V. protection. Mill thicknesses are equal to the original O.E. stripes. Individually boxed.

#### Stripe Kit, GT

65-66	Black	.....	C5ZZ-6520000-A
65-66	White	.....	C5ZZ-6520000-B
65-66	Red	.....	C5ZZ-6520000-C
65-66	Blue	.....	C5ZZ-6520000-D
67	Black	.....	C7ZZ-6520000-A
67	White	.....	C7ZZ-6520000-B
67	Red	.....	C7ZZ-6520000-C
67	Blue	.....	C7ZZ-6520000-D
69	Black	.....	C9ZZ-6520000-A
69	White	.....	C9ZZ-6520000-B
69	Red	.....	C9ZZ-6520000-C
69	Blue	.....	C9ZZ-6520000-D
69	Gold	.....	C9ZZ-6520000-E

### MACH 1/BOSS 351/RALLY STRIPE KIT

Excellent quality automotive grade vinyls. All of our stripe kits have special agents added for U.V. protection. Mill thicknesses are equal to the original O.E. stripes. Mach 1 kits include trunk

stripe.

#### Stripe Kit, Mach 1/Boss 351/Rally



69: Mach 1, Black/Gold\*  
C9ZZ-6320000-A



69: Mach 1, Red/Gold\*  
C9ZZ-6320000-C



69: Mach 1, Gold/White\*  
C9ZZ-6320000-G



71-72: Boss, Rally, Black, side stripe only  
D1ZZ-6320000-A



71-72: Boss, Rally, Argent, side stripe only  
D1ZZ-6320000-R



73: Mach 1, Argent\*  
D3ZZ-6320000-A



73: Mach 1, Black\*  
D3ZZ-6320000-BK

### SHELBY STRIPE KIT



Our quality reproduction stripe kits come with installation instructions. Individually

boxed. S7MS-16224-B pictured.

#### Stripe Kit, Shelby

65	Blue	.....	S1MS-16224-B
66	Hertz gold	.....	S2MS-16224-G
66-68	Black GT350	.....	S2MS-16224-A
66-68	White GT350	.....	S2MS-16224-B
66-68	Red GT350	.....	S2MS-16224-C
66-68	Blue GT350	.....	S2MS-16224-D
67L-8	Black GT500	.....	S7MS-16224-A
67E	Black GT500	.....	S7MS-16224-AE
67L-8	White GT500	.....	S7MS-16224-B
67E	White GT500	.....	S7MS-16224-BE
67L-8	Blue GT500	.....	S7MS-16224-D
67E	Blue GT500	.....	S7MS-16224-DE
67E	White GT500	.....	S7MS-16224-F
67E	Black GT500	.....	S7MS-16224-G
67E	Blue GT500	.....	S7MS-16224-H

Decals/Stripes

WE PROUDLY FEATURE AUTHENTIC MUSTANG REPRODUCTIONS FROM SCOTT DRAKE ENTERPRISES!



33

Authorized Dealer

**Stripe Kit, Shelby**

- 68 Black, GT500 KR side stripe S8MS-16224-B
- 69-70 Black GT350 .....S9MS-16224-A
- 69-70 White GT350 .....S9MS-16224-B
- 69-70 White GT500 .....S9MS-16224-C
- 69-70 Gold GT500 .....S9MS-16224-E
- 69-70 Black, GT500<sup>s</sup> .....S9MS-16224-F
- 69-70 Gold GT350<sup>s</sup> .....S9MS-16224-G
- 69-70 Blue, GT500<sup>s</sup> .....S9MS-16224-H

**TRUNK LID STRIPE KIT**

Excellent quality automotive grade vinyls. All of our stripe kits have special agents added for U.V. protection. Mill thicknesses are equal to the original O.E. stripes.  
**Stripe Kit, Trunk Lid**



**DEARBORN HOOD STRIPE STENCIL**

A stencil kit to help you get those stripes straight when repainting the hood.



- Stripe Stencil, Dearborn Hood**  
70 351 For hood\* .....GE-811-351

**Stripe Stencil, Dearborn Hood**

- 70 428 For hood\* .....GE-811-428

**SHAKER HOOD STRIPE STENCIL**

A stencil kit to help you get those stripes straight when repainting the hood.

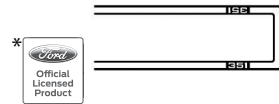

**Stripe Stencil, Shaker Hood**

- 70 351 For hood\* .....GE-812-351  
70 428 For hood\* .....GE-812-428

**TRUNK COMPARTMENT DECALS**

**FORD SAFETY ACT DECAL**

This decal assured that your new car complied with federal safety laws when it was delivered to the customer.  
**Decal, Ford Safety Act**



- 66-68  
DF-665



- 68-69  
DF-168

**JACK INSTRUCTION DECAL**

Instructions for the use and storage of the stock jack.

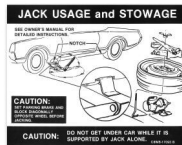

**Decal, Jack Instruction**

- 65 ..... DF-145
- 66 ..... DF-146
- 67 Early 1967 ..... DF-371
- 67-68 Late 1967, and 1968 ..... DF-44
- 68 Styled steel wheel ..... DF-374
- 68-70 Space saver ..... DF-368
- 69-70 Styled wheel ..... DF-77
- 69-70 Regular wheel ..... DF-78
- 71 Regular wheel, early 1971 ..... DF-46
- 71 Space saver spare, late 1971 ..... DF-218
- 71 Space saver ..... DF-367
- 71-72 Regular wheel, 1971/72 ..... DF-413
- 71-72 Space saver ..... DF-414
- 73 Convertible ..... DF-465
- 73 Coupe ..... DF-653

**SHELBY SAFETY ACT DECAL**

This decal was supplied to assure that the car complied with federal safety

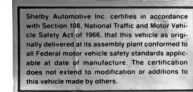

**regulations.  
Decal, Shelby Safety Act**

- 68-69<sup>s</sup> ..... DF-169

**SPACE SAVER INFLATION BOTTLE DECAL**

Original inflation instructions for the space saver "inflator" bottle.

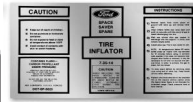

**Decal, Space Saver Inflation Bottle**

- 68 \* ..... DF-811
- 69 \* ..... DF-812
- 70 \* ..... DF-813
- 71-73 \* ..... DF-814

**SPACE SAVER SPARE INSTRUCTION DECAL**

Safety instructions for the proper use and storage of the space saver spare tire.



**Decal, Space Saver Spare Instruction**

- 68-70 ..... DF-244

**SPACE SAVER TRUNK LID DECAL**

This decal explains the use and storage of the space saver spare tire and wheel.



**Decal, Space Saver Trunk Lid**

- 68-70 \* ..... DF-281

**B.F. GOODRICH SPACE SAVER POSTCARD**

A post card that was sent to owners of cars equipped with space saver tires to warn of possible problems.



**Postcard, B.F. Goodrich Space Saver**

- 68-71 ..... DF-807

## WINDOW DECALS

### COBRA WINDOW DECAL

These self-adhesive decals look great on your front or back windshield or just about anywhere around the home or shop. 3 different cobra styles to choose from.

#### Window Decal, Cobra



64-73: Cobra Jet with burning wheels<sup>§</sup>  
DF-393



64-73: Cobra with burning wheels<sup>§</sup>  
DF-822

### MUSCLE POWER WINDOW DECAL



A brightly colored sticker that is reminiscent of the 70's flower power theme.

#### Window Decal, Muscle Power

64-73 For inside window ..... DZ-113  
64-73 For outside window ..... DZ-114

### PRODUCTION DAY WINDOW DECAL



This decal was used to tell what day the car was produced.

#### Window Decal, Production Day

64-75 Day 7 ..... DF-1012

### RUNNING HORSE WINDOW DECAL

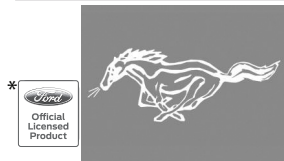

These self-adhesive decals look great on your front or back windshield

or just about anywhere around the home or shop.

#### Window Decal, Running Horse

64-73 White, 13" x 34" \* ..... ACC-13WD-W

## DOORS PARTS

### ARMRESTS

#### ARM REST BASE



Precision molded of stress-resistant plastic, with a smooth durable chrome finish.

#### Arm Rest Base

64-66 ..... CSZZ-6524144-A

#### ARM REST BASE AND PAD KIT



Each kit contains a pair of arm rest pads and bases. Arm rest pads feature correct texture and molded in color. Steel insert

for strength. Extra thick vinyl skin. Base is precision molded of stress resistant plastic with a smooth chrome finish. Kit includes mounting hardware.

#### Arm Rest Base and Pad Kit

64-66 Black ..... KIT-INT-2-BK  
64-66 Medium blue ..... KIT-INT-2-BL  
64-65 Bright red ..... KIT-INT-2-BR  
66 Dark blue ..... KIT-INT-2-DB  
66 Dark red ..... KIT-INT-2-DR  
64-65 White ..... KIT-INT-2-WT

#### 1964-66 ARM REST PAD



Correct texture and molded-in colors, with steel insert molded into foam to increase strength. Extra thick vinyl skins. American

made.

#### Arm Rest Pad, 1964-66

64-66 Black ..... CSZZ-6524100-BK  
66 Aqua ..... CSZZ-6524100-AQ  
64-65 Medium blue ..... CSZZ-6524100-BL  
64-65 Bright red ..... CSZZ-6524100-BR  
66 Dark blue ..... CSZZ-6524100-DB  
66 Dark red ..... CSZZ-6524100-DR  
64-66 Ivy gold ..... CSZZ-6524100-IG  
64-65 Palomino ..... CSZZ-6524100-PA  
66 Parchment ..... CSZZ-6524100-PR  
64-65 White ..... CSZZ-6524100-WT

#### 1967 ARM REST PAD



Correct texture and molded-in colors, with steel insert molded into foam to increase strength. Extra thick vinyl skins. American

made.

#### Arm Rest Pad, 1967

67 Black ..... C7ZZ-6524100-BK  
67 Red ..... C7ZZ-6524100-RD  
67 Blue ..... C7ZZ-6524100-BL  
67 Aqua ..... C7ZZ-6524100-AQ  
67 Ivy gold ..... C7ZZ-6524100-IG  
67 Parchment ..... C7ZZ-6524100-PR  
67 Saddle ..... C7ZZ-6524100-SA

#### 1968 ARM REST PAD



Correct texture and molded-in colors, with steel insert molded into foam to increase strength. Extra thick vinyl skins. American

made.

#### Arm Rest Pad, 1968

68 Black, right hand ..... C8ZZ-6524100-BK  
68 Black, left hand ..... C8ZZ-6524101-BK  
68 Red, right hand ..... C8ZZ-6524100-RD  
68 Red, left hand ..... C8ZZ-6524101-RD  
68 Blue, right hand ..... C8ZZ-6524100-BL  
68 Blue, left hand ..... C8ZZ-6524101-BL  
68 Aqua, right hand ..... C8ZZ-6524100-AQ  
68 Aqua, left hand ..... C8ZZ-6524101-AQ  
68 Ivy gold, right hand ... C8ZZ-6524100-IG  
68 Ivy gold, left hand .... C8ZZ-6524101-IG  
68 Parchment, right hand .....  
C8ZZ-6524100-PR  
68 Parchment, left hand C8ZZ-6524101-PR  
68 Saddle, right hand ....C8ZZ-6524100-SA  
68 Saddle, left hand .....C8ZZ-6524101-SA

#### 1968 DELUXE ARM REST PAD



Correct texture and molded-in colors, with steel insert molded into foam to increase strength. Extra thick vinyl skins. American

made.

#### Arm Rest Pad, 1968 Deluxe

68 Black, right hand ..... C8ZZ-6524100BKD  
68 Black, left hand ..... C8ZZ-6524101BKD  
68 Blue, right hand ..... C8ZZ-6524100BLD  
68 Blue, left hand ..... C8ZZ-6524101BLD  
68 Aqua, right hand .... C8ZZ-6524100AQD  
68 Aqua, left hand ..... C8ZZ-6524101AQD  
68 Ivy gold, right hand ...C8ZZ-6524100IGD  
68 Ivy gold, left hand ....C8ZZ-6524101IGD  
68 Maroon, right hand .C8ZZ-6524100MRD  
68 Maroon, left hand ...C8ZZ-6524101MRD

WE PROUDLY FEATURE AUTHENTIC MUSTANG REPRODUCTIONS FROM SCOTT DRAKE ENTERPRISES!



**Arm Rest Pad, 1968 Deluxe**

- 68 Parchment, right hand ..... C8ZZ-6524100PRD
- 68 Parchment, left hand C8ZZ-6524101PRD
- 68 Saddle, right hand ....C8ZZ-6524100SAD
- 68 Saddle, left hand .....C8ZZ-6524101SAD

**1969-70 ARM REST PAD**

Correct texture and molded-in colors, with steel insert molded into foam to increase strength. Extra thick vinyl skins. American

made. Note: Ford used 2 different arm rest pads in 69-70. We currently offer only 1 version. Mounting holes are approximately 12 1/4" from center to center on our pads. Some cars measured approximately 13". These cars will require relocating one mounting hole before door panel is installed.

**Arm Rest Pad, 1969-70**

- 69-70 Black, right hand ..... C9ZZ-6524100-BK
- 69-70 Black, left hand ..... C9ZZ-6524101-BK
- 69-70 White, right hand .....C9ZZ-6524100-WT
- 69-70 White, left hand .....C9ZZ-6524101-WT

**1971-73 ARM REST PAD**

Correct texture and molded-in colors, with steel insert molded into foam to increase strength. Extra thick vinyl skins. American

made.

**Arm Rest Pad, 1971-73**

- 71-73 Black, right hand ..... D1ZZ-6524100-BK
- 71-73 Black, left hand ..... D1ZZ-6524101-BK
- 71-73 Blue, right hand ..... D1ZZ-6524100-BL
- 71-73 Blue, left hand ..... D1ZZ-6524101-BL
- 71-73 Ginger, right hand ..... D1ZZ-6524100-GI
- 71-73 Ginger, left hand ..... D1ZZ-6524101-GI

**ARM REST PAD BASE****Arm Rest Pad Base**

- 71-73 Standard interior ..... D1AZ-5724144-A

**ARM REST PLUG**

Perfect detail in these often missing plugs.

**Arm Rest Plug**

- 67 Black, deluxe ..... C7ZZ-6524056-BK

**Arm Rest Plug**

- 67 Parchment, deluxe ... C7ZZ-6524056-PR
- 68 Black, deluxe, set of 4 C8ZZ-6524056-BK
- 68 Parchment, deluxe, set of 4 ..... C8ZZ-6524056-PR

**DOOR HANDLES & WINDOW CRANKS, INSIDE****INSIDE DOOR HANDLE**

Excellent reproductions of the originals, fit is perfect. All of these handles feature a brightly polished, chrome finish or our custom satin chrome finish.

**Door Handle, Inside**

- 64-65: Early 65, right hand or left hand C3AZ-6222600-B



- 65-67: Late 65, right hand or left hand C5ZZ-6522600-C



- 65-66: Deluxe, right hand C5ZZ-6522600-A



- 65-66: Deluxe, left hand C5ZZ-6522601-A



- 65-66: Deluxe, wood with satin finish, pair C5ZZ-65226001WS



- 65-66: Deluxe, leather, pair C5ZZ-6522600/1L



- 65-66: Deluxe, leather with satin finish, pair C5ZZ-65226001LS



- 67: Deluxe, right hand or left hand C7ZZ-6522600-A



- 68: Right hand C7AZ-5422600-B

**Door Handle, Inside**

- 68: Left hand C7AZ-5422601-B



- 68: Right hand, satin C7AZ-5422600-S



- 68: Left hand, satin C7AZ-5422601-S



- 69-70: Right hand C9AZ-6222600-A



- 69-70: Left hand C9AZ-6222601-A



- 71-73: Deluxe, right hand D1ZZ-6522600-A



- 71-73: Deluxe, left hand D1ZZ-6522601-A

**INSIDE DOOR HANDLE & WINDOW CRANK KIT**

Kit includes clip or screw-on door handles, window cranks, quarter window cranks (for coupe and

convertible), clips/screws and backing plates.

**Door Handle & Window Crank Kit, Inside**

- 64-65 Early 65 coupe or convertible, chrome ... KIT-DH-2
- 65 Early 65 fastback, chrome .....KIT-DH-1
- 65-67 Late 65 fastback, chrome .....KIT-DH-3
- 65-67 Late 65 fastback, satin ..... KIT-DH-3S
- 65-67 Late 65 coupe or convertible, chrome .... KIT-DH-4
- 65-67 Late 65 coupe or convertible, satin ..... KIT-DH-4S
- 68 Fastback, chrome .....KIT-DH-7
- 68 Coupe or convertible, chrome ..KIT-DH-8

**INSIDE DOOR HANDLE & WINDOW CRANK SCREW**

We have these exact reproductions made especially for us. You want to use right parts, not something close, 65-66 are chrome plated just like the originals. Sold in sets of 4.  
**Door Handle & Window Crank Screw, Inside**

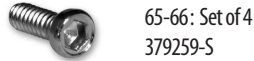

65-66: Set of 4  
379259-S



67-70: Set of 4  
381571-S

**DOOR HANDLE & WINDOW CRANK SPRING**



Black lacquer finished to prevent rust. Fits behind door panel.

**Door Handle & Window Crank Spring**  
64-67 ..... B7A-7022624-A

**DOOR HANDLE BEZEL**



Trim behind door handle. Mounts on door before door panel is installed.

**Door Handle Bezel**  
69-70 Deluxe interior ..... C9ZZ-6522634-D

**DOOR HANDLE CLIP REMOVER**



Removes special retaining clip on early door handles and window cranks. Stamped steel construction.

**Door Handle Clip Remover**  
64-65 ..... T-87600

**DOOR HANDLE SPRING CLIP**



Small spring clip, copper plated just like the originals. Used to attach door handle and window crank to door shaft.

**Door Handle Spring Clip**  
64-65 ..... 357550-S

**DOOR WINDOW CRANK**

Highly detailed die-cast zinc construction. Finished in beautiful chrome or satin chrome. Our handles feature much better detail than others.

**Window Crank, Door**



64-65: Early 65, chrome  
C4SZ-6323342-A



65-67: Late 65, chrome  
C5ZZ-6523342-C



68-70: Chrome  
C8AZ-6223342-A



68-70: Satin  
C8AZ-6223342-S



71-72: Chrome, w/out knob  
C9UZ-8223342

**QUARTER WINDOW CRANK**

Quarter window crank handle, made by Scott Drake. Like all our handles, these feature better detail and better chrome than competitors.

**Window Crank, Quarter**



65-67: Late 65, chrome  
C5ZZ-6530322-A



68-70: Chrome  
C8ZZ-6530322-A



**DELUXE WINDOW CRANK & DOOR HANDLE BACKING PLATE**



Die cast and chrome plated. New improved design is very wear resistant. Also included are nylon bushings to prevent scratches.

**Window Crank & Door Handle Backing Plate, Deluxe**

65-66 Chrome ..... C4SY-6322620/1A  
65-66 Satin ..... C4SY-6322620/1S

**WHITE, INSIDE WINDOW CRANK & DOOR HANDLE BACKING PLATE**



Protects door panels from the abrasive action of rotating handles. Made from a very hard nylon type material. Ours feature

the correct milky white color.

**Window Crank & Door Handle Backing Plate, White, Inside**

64 Door ..... C3AZ-6223370-A  
65-70 Door ..... C5AZ-6223370-A  
64-67 Quarter window ..... C4SZ-6323370-A  
68-73 Door ..... C8AZ-6223370-A

**CHROME, INSIDE WINDOW CRANK BACKING PLATE**



The original plates are either missing, cracked or no longer chrome. Our plates are made with a bright chrome finish to really catch

the eye.

**Window Crank Backing Plate, Chrome, Inside**

69-70 Chrome ..... C9ZZ-6523370-A

**WINDOW CRANK HANDLE COVER PLATE**



This is a aluminum disc that covers the window crank handle screw hole. Stamped aluminum with circular brushed finish and

adhesive backed.

**Window Crank Handle Cover Plate**

68-73 ..... C8AZ-6223362-A

**WINDOW CRANK KNOB**

A premium reproduction. The knob is vinyl-molded and has a plastic insert just like the original. Mounting pin and wave washer are also included.

**Window Crank Knob**



68-70: Clear/Silver  
C8AZ-6223352-CL

Door Parts

**WE PROUDLY FEATURE AUTHENTIC MUSTANG REPRODUCTIONS FROM SCOTT DRAKE ENTERPRISES!**



**Window Crank Knob**



68-70: Ivy gold  
C8AZ-6223352-IG



68-70: Maroon  
C8AZ-6223352-MR



68-73: Black  
C8AZ-6223352-BK



68-73: Blue  
C8AZ-6223352-BL



68-73: Ginger  
C8AZ-6223352-GI



68-73: Green  
C8AZ-6223352-GR



68-73: Parchment and nugget gold  
C8AZ-6223352-PR



68-73: Vermillion  
C8AZ-6223352-VE



68-73: White  
C8AZ-6223352-WT

**Door Parts**

**DOOR HANDLES, OUTSIDE**

**OUTSIDE DOOR HANDLE**



Economy version

Our door handles are "Show Quality" and available in 3 finishes: polished chrome, satin chrome, and black chrome. Our 64-70

handles come in kits that include both left and right handles, buttons, pads, hardware and brackets.

**Door Handle, Outside**

64-70 Economy, chrome Fits: 64-66, 69-70. Not made by Drake (\*69-70 cars must re-use some of their original hardware.) ..... C4DZ-6222404/5A

64-66 Show-quality, chrome ..... C4DZ-6222404/5P

64-66 Show-quality, satin chrome ..... C4DZ-6222404/5S

64-66 Show-quality, black chrome ..... C4DZ-6222404/5B

67-68 Economy, chrome (Not made by Drake.) .. C7ZZ-6522404/5A

67-68 Show-quality, chrome C7ZZ-6522404/5P

67-68 Show-quality, satin chrome ..... C7ZZ-6522404/5S

67-68 Show-quality, black chrome ..... C7ZZ-6522404/5B

69-70 Show-quality, chrome C9ZZ-6222404/5P

69-70 Show-quality, satin chrome ..... C9ZZ-6222404/5S

71-73 Chrome, left hand and right hand ..... D1ZZ-6222404/5A

**OUTSIDE DOOR HANDLE PAD**



Fit between door handle and door body panel. Injection-molded plastic just like the original. Sold in complete sets only. 4

piece sets.

**Outside Door Handle Pad**

64-70 Does not fit 67-68 .... CODZ-6422428/9K

67-68 ..... C7ZZ-6522428/9K

**DOOR HINGES**

**DOOR HINGE**



Reproduction cast-iron or stamped steel door hinges that look and work right. Painted natural steel gray. Painted black.

**Door Hinge**

64-66 Right hand, upper .... C5ZZ-6522800-BR

64-66 Left hand, upper ..... C5ZZ-6522801-BR

64-66 Right hand, lower ..... C5ZZ-6522810-BR

64-66 Left hand, lower ..... C5ZZ-6522811-BR

67-68 Right hand, upper ..... C7ZZ-6522800-C

67-68 Left hand, upper ..... C7ZZ-6522801-C

67-68 Right hand, lower ..... C7ZZ-6522810-CR

67-68 Left hand, lower ..... C7ZZ-6522811-CR

69-70 Right hand, lower ..... C9ZZ-6522810-A

69-70 Left hand, lower ..... C9ZZ-6522811-A

69-70 Right hand, upper ..... D0ZZ-6522800-A

69-70 Left hand, upper ..... D0ZZ-6522801-A

**Door Hinge**

71-73 Right hand, upper ..... D10Z-6522800-A

71-73 Left hand, upper ..... D10Z-6522801-A

71-73 Right hand, lower ..... D10Z-6522810-A

71-73 Left hand, lower ..... D10Z-6522811-A

**DOOR HINGE BUSHING**



Machined brass to original factory specs. Requires 2 per pin.

**Door Hinge Bushing**

64-70 ..... C3AZ-5422841-A

**DOOR HINGE PIN**



Machined just like the original.

**Door Hinge Pin**

64-68 2 1/2" ..... B9A-5943030-AA

64-73 4" ..... B9A-5943030-LG

**DOOR HINGE REPAIR KIT**



Contains all necessary parts including pins, bushings, a new cam plate, spring, and roller to rebuild both upper and lower hinges.

**Door Hinge Repair Kit**

64-67 ..... C5ZZ-6522800-K

**DOOR HINGE REPAIR SPRING**



Spring to reload tension in door hinge. Compression tool also available.

**Door Hinge Repair Spring**

64-68 ..... CODZ-6421232-B

**DOOR LATCHES**

**DOOR LATCH**



This door latch assembly is a beautiful copy of a complicated stamping. Comes fully assembled and ready to install.

**Door Latch**

65-66 Right hand ..... C4SZ-6321812-C

65-66 Left hand ..... C4SZ-6321813-C

67-68 Right hand ..... C60Z-6221812-A

67-68 Left hand ..... C60Z-6221813-A

69-70 Right hand ..... C9AZ-6221812-A

**Door Latch**

- 69-70 Left hand .....C9AZ-6221813-A
- 71-73 Right hand ..... D30Z-6521812-A
- 71-73 Left hand ..... D30Z-6521813-A

**DOOR LATCH REINFORCEMENT KIT**



Door Latch Reinforcement Kit Does Both Doors, 12 piece kit includes 6 bolts and 6 washers.

- Door Latch Reinforcement Kit 64-70 .....C0DB-3447

**DOOR LATCH RETAINER BUSHING KIT**



Door Latch Retainer Bushing. 4 piece kit.

- Door Latch Retainer Bushing Kit 64-66 ..... C4SZ-6321801-C

**DOOR LATCH ROD CONTROL SET**



This convenient rod kit does both doors. Includes zinc plated rods, door lock rod clips, and all necessary mounting hardware.

- Door Latch Rod Control Set 67-68 .....C7ZZ-6521940-KT
- 69-70 .....C9ZZ-6521940-KT

**DOOR LATCH ROD RETAINER**

**Door Latch Rod Retainer**



64-66: Concours C3AZ-6221952-BR



65-66: Economy replacement C3AZ-6221952-A



67-73: Concours CSAZ-6221952-AR

**DOOR LATCH SCREW**



Correct screws with special star washers. Set of six.

- Door Latch Screw 64-70 Set of 6 .....356782-5

**DOOR LATCH SPRING**



Correct stainless steel spring for door latch.

- Door Latch Spring 67-70 .....357212-5

**DOOR LOCK KNOB**

Made by Plastic injection. Sold as a pair. Available in chrome, or satin chrome.

**Door Lock Knob**



64-66: Chrome C5DZ-6221850-A



64-66: Satin chrome C5DZ-6221850-S



67: Chrome C5AZ-6221850-A



68-73: Chrome C8AZ-6221850-A

**DOOR LOCK KNOB GROMMET**

The grommet that goes around the door lock knob, comes in clear, chrome or stainless.

**Door Lock Knob Grommet**



64-70: 65-68 All, 69-73 Standard interior: Clear plastic C5DZ-6221999-B



65-73: 65-68 All, 69-73 Standard interior: Chrome C5DZ-6221999-C

**Door Lock Knob Grommet**



69-73: Stainless steel, deluxe interior D0DZ-6221999-AR

**DOOR LOCK ROD**



Zinc plated rods that are bent correctly.

**Door Lock Rod**

- 65-66 Left hand, set of 3 ..... C5ZZ-65213452LH
- 65-66 Right hand, set of 3 ...C5ZZ-65213452RH
- 67-68 Left hand, set of 3 ..... C7ZZ-65213452LH
- 67-68 Right hand, set of 3 ...C7ZZ-65213452RH

**DOOR SHAFT ASSEMBLY**



Gold cadmium plated and made from our own tooling. Our 64-66 standard interior shafts will accomodate early clip-on handles.

**Door Shaft Assembly**

- 64-66 Standard, Right hand .. C5ZZ-6521818-C
- 64-66 Standard, Left hand .... C5ZZ-6521819-C
- 65-66 Pony, right hand ..... C5ZZ-6521818-B
- 65-66 Pony, left hand ..... C5ZZ-6521819-B
- 67-68 Right hand .....C60Z-6221818-B
- 67-68 Left hand .....C60Z-6221819-B

**DOOR LIGHTS**

**DOOR COURTESY LIGHT ASSEMBLY**

These assemblies feature bright white lenses, beautiful chrome plating, correct wiring and housing. Mounting hardware included. These are the best on the market.

**Door Courtesy Light Assembly**



65-66: Deluxe CSZZ-13786



67-68: Deluxe C7ZB-13A744-C



69-70: Deluxe, set of 2 C9WY-13776/7-A

Door Parts

**WE PROUDLY FEATURE AUTHENTIC MUSTANG REPRODUCTIONS FROM SCOTT DRAKE ENTERPRISES!**





## DOOR COURTESY LIGHT LENS



Replace those yellowed lenses with our clean white reproduction. Sold in matching pairs.

Door Courtesy Light Lens  
67-68 Deluxe .....C7ZZ-13731-B

## DOOR PANELS & COMPONENTS

### DOOR INNER UPPER TRIM



Door Inner Upper Trim  
69-70 Standard interior, Right hand .....  
C9ZZ-6520904-A  
69-70 Standard interior, left hand .....  
C9ZZ-6520905-A

### 1964-65 DOOR PANEL



Our door panels are upholstered with the original material, mounted on precision die-cut fiberboard. Colors and textures

are identical to the originals. Includes chrome plated plastic trim where appropriate.

#### Door Panel, 1964-65

64-65 Black .....C5ZZ-65239423BK  
64-65 Blue .....C5ZZ-65239423BL  
64-65 Ivy gold .....C5ZZ-65239423IG  
64-65 Palamino .....C5ZZ-65239423PA  
64-65 Red .....C5ZZ-65239423RD  
64-65 White .....C5ZZ-65239423WT

### 1965-66 DELUXE DOOR PANEL



These panels are the finest available. Excellent molded vinyl surface with the correct grain. Foam filled on treated

pressboard. These door panels DO NOT include stainless steel trim pieces.

#### Door Panel, 1965-66 Deluxe

65 Bright red .....C5ZZ65239423RDP  
65-66 Black .....C5ZZ65239423BKP  
65-66 White .....C5ZZ65239423WTP  
66 Dark red .....C5ZZ65239423DRP  
66 Parchment .....C5ZZ65239423PRP

## 1966 DOOR PANEL



Our door panels are upholstered with the original material, mounted on precision die-cut fiberboard. Colors and textures

are identical to the originals. Includes chrome plated plastic trim where appropriate.

#### Door Panel, 1966

66 Black .....C6ZZ-65239423BK  
66 Aqua .....C6ZZ-65239423AQ  
66 Blue .....C6ZZ-65239423BL  
66 Dark red .....C6ZZ-65239423DR  
66 Parchment .....C6ZZ-65239423PR

## 1967 DOOR PANEL



Our door panels are upholstered with the original material, mounted on precision die-cut fiberboard. Colors and textures

are identical to the originals. Includes chrome plated plastic trim where appropriate.

#### Door Panel, 1967

67 Black .....C7ZZ-65239423BK  
67 Aqua .....C7ZZ-65239423AQ  
67 Blue .....C7ZZ-65239423BL  
67 Ivy gold .....C7ZZ-65239423IG  
67 Parchment .....C7ZZ-65239423PR  
67 Red .....C7ZZ-65239423RD  
67 Saddle .....C7ZZ-65239423SA

## 1967 DELUXE DOOR PANEL



These panels are the finest available. Excellent molded vinyl surface with the correct grain. Foam filled on treated

pressboard. These door panels do not include stainless steel trim pieces, or aluminum inserts.

#### Door Panel, 1967 Deluxe

67 Black .....C7ZZ65239423BKD  
67 Blue .....C7ZZ65239423BLD  
67 Ivy gold .....C7ZZ65239423IGD  
67 Parchment .....C7ZZ65239423PRD  
67 Red .....C7ZZ65239423RDD

## 1968 DOOR PANEL

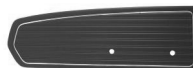

Our door panels are upholstered with the original material, mounted on precision die-cut fiberboard. Colors and textures

are identical to the originals. Includes chrome plated plastic trim where appropriate.

#### Door Panel, 1968

68 Black .....C8ZZ-65239423BK  
68 Blue .....C8ZZ-65239423BL

## Door Panel, 1968

68 Ivy gold .....C8ZZ-65239423IG  
68 Maroon .....C8ZZ-65239423MR  
68 Nugget gold .....C8ZZ-65239423NG  
68 Parchment .....C8ZZ-65239423PR  
68 Saddle .....C8ZZ-65239423SA

## 1968 DELUXE DOOR PANEL



These panels are the finest available. Chrome trim and woodgrain inserts installed as original.

#### Door Panel, 1968 Deluxe

68 Black .....C8ZZ65239423BKD  
68 Aqua .....C8ZZ65239423AQD  
68 Blue .....C8ZZ65239423BLD  
68 Ivy gold .....C8ZZ65239423IGD  
68 Maroon .....C8ZZ65239423MRD  
68 Nugget gold .....C8ZZ65239423NGD  
68 Parchment .....C8ZZ65239423PRD  
68 Saddle .....C8ZZ65239423SAD

## 1969 STANDARD DOOR PANEL



Our door panels are upholstered with the original material, mounted on precision die-cut fiberboard. Colors and textures

are identical to the originals. Includes chrome plated plastic trim where appropriate.

#### Door Panel, 1969 Standard

69 Black .....C9ZZ-65239423BK  
69 Dark ivy gold .....C9ZZ-65239423DI  
69 Dark red .....C9ZZ-65239423DR  
69 Light blue .....C9ZZ-65239423LB  
69 Nugget gold .....C9ZZ-65239423NG  
69 White .....C9ZZ-65239423WT

## 1969-70 DELUXE DOOR PANEL



These panels are the finest available. Excellent molded vinyl surface with the correct grain. Foam filled on treated

pressboard. These door panels do not include stainless steel trim pieces, or aluminum inserts. Some cutting may be required.

#### Door Panel, 1969-70 Deluxe

69 Black with black carpet .....  
C9ZZ65239423BKD  
69 Dark red with maroon carpet .....  
C9ZZ65239423DRD  
69 White with black carpet .....  
C9ZZ65239423WTD  
70 Medium blue with blue carpet .....  
C9ZZ65239423BLD

**Door Panel, 1969-70 Deluxe**

- 70 Black with black carpet ..... D0ZZ65239423BKD
- 70 Ginger with dark brown carpet ..... D0ZZ65239423GID
- 70 White with black carpet ..... D0ZZ65239423WTD

**1970 DOOR PANEL**



Our door panels are upholstered with the original material, mounted on precision die-cut fiberboard. Colors and textures

are identical to the originals. Includes chrome plated plastic trim where appropriate.

**Door Panel, 1970**

- 70 Black ..... D0ZZ-65239423BK
- 70 Blue ..... D0ZZ-65239423BL
- 70 Bright red ..... D0ZZ-65239423BR
- 70 Ivy gold ..... D0ZZ-65239423IG
- 70 White ..... D0ZZ-65239423WT

**1971-73 DOOR PANEL**



Our door panels are upholstered with the original material, mounted on precision die-cut fiberboard. Colors and textures

are identical to the originals. Includes chrome plated plastic trim where appropriate.

**Door Panel, 1971-73**

- 71-73 Black ..... D1ZZ-65239423BK
- 71-73 Blue ..... D1ZZ-65239423BL
- 71-73 Bright red ..... D1ZZ-65239423BR
- 71-73 Ginger ..... D1ZZ-65239423GI
- 71-73 Green ..... D1ZZ-65239423GR
- 71-73 Ivy gold ..... D1ZZ-65239423IG
- 71-73 White ..... D1ZZ-65239423WT

**1971-73 DELUXE DOOR PANEL**



These panels are the finest available. Excellent molded vinyl surface with the correct grain. Foam filled on treated

pressboard. These door panels do not include stainless steel trim pieces, or aluminum inserts.

**Door Panel, 1971-73 Deluxe**

- 71-73 Black ..... D1ZZ65239423BKD
- 71-73 Medium blue ..... D1ZZ65239423BLD
- 71-73 Ginger ..... D1ZZ65239423GID
- 71-73 White ..... D1ZZ65239423WTD

**2-TONE DOOR PANEL**



Made with tough Masonite backing instead of cardboard for extra durability and easy installation. Two-tone panels are

available in a variety of color combinations.

**Door Panel, 2-Tone**

- 65 Blue/white ..... C5ZZ65239423B/W
- 65 Black/white ..... C5ZZ65239423BK/W
- 65 Ivy gold/white ..... C5ZZ65239423I/W
- 65 Palamino/white ..... C5ZZ65239423P/W
- 65 Bright red/white ..... C5ZZ65239423R/W
- 66 Aqua/white ..... C6ZZ65239423A/W
- 66 Blue/white ..... C6ZZ65239423B/W
- 66 Black/white ..... C6ZZ65239423BK/W
- 66 Light blue/white ..... C6ZZ65239423LB/W
- 66 Parchment/white ..... C6ZZ65239423P/W
- 66 Dark red/white ..... C6ZZ65239423R/W
- 67 Aqua/white ..... C7ZZ65239423A/W
- 67 Blue/white ..... C7ZZ65239423B/W
- 67 Black/white ..... C7ZZ65239423BK/W
- 67 Ivy gold/white ..... C7ZZ65239423I/W
- 67 Parchment/white ..... C7ZZ65239423P/W
- 67 Dark red/white ..... C7ZZ65239423R/W
- 67 Saddle/white ..... C7ZZ65239423S/W

**DOOR WATERSHIELD**



Protects door panels and upholstery from water damage. Specially treated paper, precisely die-cut for an easy installation.

These are exact copies of the originals. **We will be offering a Deluxe version that offers insulation and sound deadening properties. Available Summer 2012. Just add "-D" to the part numbers below to order the "Deluxe" version.**

**Door Watershield**

- 64-66 Coupe ..... C5ZZ-65-WS
- 64-66 Convertible ..... C5ZZ-76-WS
- 65-66 Fastback ..... C5ZZ-63-WS
- 67-68 Fastback ..... C7ZZ-63-WS
- 67-68 Coupe ..... C7ZZ-65-WS
- 67-68 Convertible ..... C7ZZ-76-WS
- 69-70 Fastback ..... C9ZZ-63-WS
- 69-70 Coupe ..... C9ZZ-65-WS
- 69-70 Convertible ..... C9ZZ-76-WS
- 71-73 Fastback ..... D1ZZ-63-WS
- 71-73 Coupe ..... D1ZZ-65-WS

**Door Watershield**

- 71-73 Convertible ..... D1ZZ-76-WS

**DOOR PANEL CLIP**



High quality door panel clips in bulk or nicely packaged in a set of 30.

**Door Panel Clip**

- 64-70 Standard, set of 30, also fits 68 Deluxe ... 380552-K
- 64-70 Standard, bulk, also fits 68 Deluxe ..... 380552-S
- 65-67 Deluxe, set of 30 ..... 375553-K
- 65-67 Deluxe, bulk ..... 375553-S
- 69-70 Deluxe Mount Kit..... 375553-69D

**DOOR PANEL CUP**



Black plastic cup with correct texture and chrome beauty rings.

**Door Panel Cup**

- 69-70 Standard interior ..... C9ZZ-65226A34

**64-66 PONY DOOR PANEL CUP**

Feature perfect fit and color match. Ours are double dipped in textured vinyl just like originals.

**Door Panel Cup, 64-66 Pony**



- 64-66: Black CSZZ-6524142-BK

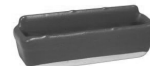

- 64-66: Bright red CSZZ-6524142-BR



- 64-66: Dark red CSZZ-6524142-DR



- 64-66: Parchment CSZZ-6524142-PR



- 64-66: White CSZZ-6524142-WT

Door Parts

**WE PROUDLY FEATURE AUTHENTIC MUSTANG REPRODUCTIONS FROM SCOTT DRAKE ENTERPRISES!**



**69-70 DELUXE DOOR PANEL CUP**



New pressure die cast zinc construction just like the originals, but stronger.

1969 version

**Door Panel Cup, 69-70 Deluxe**

69	Black, pair	.....C9ZZ6524046/7BK
69	White, pair	.....C9ZZ6524046/7WT
69	White, right hand	.....C9ZZ-6524046-WT
69	Black, right hand	.....C9ZZ-6524046-BK
69	Black, left hand	.....C9ZZ-6524047-BK
69	White, left hand	.....C9ZZ-6524047-WT
70	Black, pair	.....D0ZZ-6524046/7B
70	White, pair	.....D0ZZ-6524046/7W

**DELUXE DOOR HANDLE TRIM**

Black trim behind the door handles.



69-67	.....C9ZZ-6522634-D
-------	---------------------

**DELUXE DOOR PANEL CUP BRACKET**



This support bracket is used to fasten the Pony door cups to the inner door on 1965-67 Deluxe interiors. It takes two of these per

car.

65-67	.....CSZZ-6524140
1969	.....C9ZZ-65240A10-A
1970	.....D0ZZ-65240A10-B

**DOOR PANEL CUP PAD**

Textured rubber pad that covers the door cup mounting screws. Correct color match.



**Door Panel Cup Pad**

65-67	Black	.....CSZZ-6324046-BK
65-66	Bright red	.....CSZZ-6324046-BR
66-67	Parchment	.....CSZZ-6324046-PR
65-66	White	.....CSZZ-6324046-WT

**DOOR PANEL EMBLEM**



Beautiful detail. Features bright chrome finish and paint. Hardware included.



**Door Panel Emblem**

69-70	69 All, 70 Deluxe: Running horse*	.....C9ZB-6520820/3
-------	-----------------------------------	---------------------

**DOOR PANEL INSERT**

These deluxe door panel inserts are made of high quality brushed aluminum or vinyl woodgrain.



67: Brushed aluminum with correct polished raised bead & mounting spikes  
C7ZZ-65237A22/3



67: Brushed aluminum with correct polished raised bead & mounting spikes w/out remote mirror hole  
C7ZZ-65237A223N



69-70: Walnut  
C9ZZ-65237A22-A



69-70: Teak  
C9ZZ-65237A22-T

**DOOR PANEL INSERT WITH ALUMINUM PANEL**

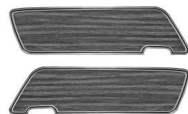

We have produced these panels from our own tooling with exact detailing right down to the black painted border. Included

is a pair of high quality, adhesive backed, woodgrain vinyl inserts, available in dark walnut or light teak. Don't forget about our beautiful mustang emblems to finish off these panels.

**Door Panel Insert with Aluminum Panel**

69-70	Teak inserts	.....C9ZZ-6523942/3T
69-70	Walnut inserts	.....C9ZZ-6523942/3W

**DELUXE DOOR PANEL KIT**



Kit includes pads, cups, brackets and mounting hardware.

**Door Panel Kit, Deluxe**

65-66	Black	.....KIT-INT5-BK
65-66	White	.....KIT-INT5-WT

**DELUXE DOOR PANEL TRIM**

Made by Scott Drake, these Deluxe Door Panel Moldings are constructed of Stainless Steel. They feature all the exact detail of the original and are designed to fit new-reproduction deluxe panels. Sold in pairs.

**Door Panel Trim, Deluxe**

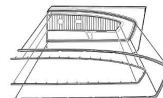

65-66: Right hand  
CSZZ-652042/70



65-66: Left hand  
CSZZ-652043/71

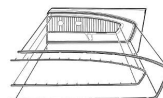

65-66: Left hand and right hand  
CSZZ-652042/71S



67: Left hand and right hand, outer only  
C7ZZ-6520970/1



69-70: Left hand and right hand  
C9ZZ-6520970/1

**DOOR PANEL U-CUP**



Now made by Drake, these are great reproductions. Made from ABS plastic, these cups feature the correct texture

on the inside and mounting pins just like the originals.

**Door Panel U-Cup**

67	Deluxe Interior, Black	C7ZZ-6524148-BK
67	Deluxe Interior, Parchment	.....C7ZZ-6524148-PR

### DELUXE DOOR PULL



Exact reproduction of the originals. Exact detail of stitches and grain pattern.

#### Door Pull, Deluxe

68	Aqua, pair	C8ZZ-6526656-AQ
68	Black, pair	C8ZZ-6526656-BK
68	Dark blue, pair	C8ZZ-6526656-BL
68	Maroon, pair	C8ZZ-6526656-MR
68	Parchment, pair	C8ZZ-6526656-PR
68	Saddle, pair	C8ZZ-6526656-SA
71-73	Black, left hand	D1ZZ-6526655-BK
71-73	Blue, left hand	D1ZZ-6526655-BL
71-73	Ginger, left hand	D1ZZ-6526655-GI
71-73	Black, right hand	D1ZZ-6526656-BK
71-73	Blue, right hand	D1ZZ-6526656-BL
71-73	Ginger, right hand	D1ZZ-6526656-GI

### INNER DOOR PULL BRACE



Exact reproduction. Includes mounting hardware and nylon inserts. Painted black.

#### Door Pull Brace, Inner

68	Deluxe interior	C8AZ-6522606-A
----	-----------------	----------------

### DOOR PULL END CAP KIT



Our door pull end caps feature beautiful chrome and wood grain insert that matches the dash and door panel wood

grain. We feel these look a lot nicer than the original. All mounting hardware included. Inner door braces sold separately.

#### Door Pull End Cap Kit

68	Deluxe interior	C7WY-6522670/6
----	-----------------	----------------

### WOODGRAIN DOOR PULL INSERTS



These are the same inserts that are available in our complete door pull end cap kit, but now available on their own.

Quickly and easily replace worn or missing inserts. Sold as a set of 4 inserts.

#### Door Pull Inserts, Woodgrain

68	Set of 4	C7WY-6522670-A
----	----------	----------------

### DOOR SPEAKER GRILLE

A nice reproduction speaker grill. Features correct screen pattern and edge molding. Includes hardware.

#### Door Speaker Grille



65-66	C6ZZ-18798-A
-------	--------------

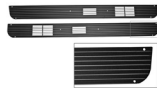

67-68: Deluxe, also fits 65-66 doors for a custom look, use C7ZN-3301 for proper installation  
C7ZZ-6520956/7A



69-70: Stereo script	C9Z-18798-A
----------------------	-------------



71-73	D2ZZ-18978-A
-------	--------------

### DOOR WATERSHIELD



Protects door panels and upholstery from water damage. Specially treated paper, precisely die-cut for an easy installation. These

are exact copies of the originals. We will be offering a Deluxe version that offers insulation and sound deadening properties. Available Summer 2012.

#### Door Watershield

65-66	Fastback	C5ZZ-63-W5
64-66	Coupe	C5ZZ-65-W5
64-66	Convertible	C5ZZ-76-W5
67-68	Fastback	C7ZZ-63-W5
67-68	Coupe	C7ZZ-65-W5
67-68	Convertible	C7ZZ-76-W5
69-70	Fastback	C9ZZ-63-W5
69-70	Coupe	C9ZZ-65-W5
69-70	Convertible	C9ZZ-76-W5
71-73	Fastback	D1ZZ-63-W5
71-73	Coupe	D1ZZ-65-W5
71-73	Convertible	D1ZZ-76-W5

## EXTERIOR DOOR PARTS

### DOOR ACCESS PLUG



Steel stamped with nickel plating. Original should be painted body color.

#### Door Access Plug

64-66	Set of 4	C5ZZ-6522286
-------	----------	--------------

### DOOR AND QUARTER SEAL SCREW



Used to secure the seals both on the quarter panel and on the rear of the door window seal. Black oxide finish.

#### Door And Quarter Seal Screw

64-73	Bulk, sold in bags of 100	52718-SMK
65-68	Set of 22	52718-S

### DOOR BUMPER



Made from first-class E.P.D.M. rubber. Usually eliminates door rattling by replacing those stone-hard originals. Available in

bulk or sets of 4.

#### Door Bumper

64-68	Bulk	C2AZ-6223030-A
64-68	Set of 4	C2AZ-6223030-K
69-73	Set of 4	C7AZ-54265A28AA

### DOOR EDGE GUARD



Protects paint, made from rust resistant stainless steel.

#### Door Edge Guard

64-66	Set of 4	C5ZZ-6520910/1
67-68	Set of 4	C7ZZ-6520910/1
69-70	Set of 4	C9ZZ-6520910/1
69-70	Set of 4	C9ZZ-6520970/1
71-73	Set of 4	D1ZZ-6520910/1

### DOOR HINGE MOUNT KIT



OE looking bolts with built in washers. Black oxide finish.

#### Door Hinge Mount Kit

64-65	6 bolts, black, 3/8" threads	379043-SMK
66-68	6 bolts, black, 5/16" threads	380575-S2

### DOOR TAG PLATE



Exact copies of the original data plate tags. Reverse stamped, like originals, to match your cars specifications.

Attaches to driver's door inside jam. Specify VIN, body, color, trim, date of manufacture, DSO, axle and transmission codes. Authentic mounting rivets are also included. Must fax or email your VIN info. Allow 3 weeks to receive.

#### Door Tag Plate

64-69	With rivets	DT-1
-------	-------------	------

**WE PROUDLY FEATURE AUTHENTIC MUSTANG REPRODUCTIONS FROM SCOTT DRAKE ENTERPRISES!**



**DOOR TAG PLATE RIVETS**

Special aluminum attaching rivets. Authentic look.



Door Tag Plate Rivets  
64-69 ..... CSZZ-6223000-A

**FRONT DOOR TO WINDOW SEAL**

Made from a high quality rubber. These feature a steel insert molded inside. Fits on rear door edge.  
Door To Window Seal, Front



64-66  
CSZZ-6520588/9B



67: Early 67 Cougar  
C7ZZ-6520588/9A



67-68: Late 67 Cougar  
C7ZZ-6520588/9B



69-70  
C9ZZ-6520264/5A

**REAR VERTICAL GLASS RUN REPAIR KIT**

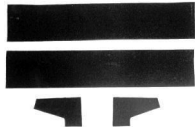

Original type style mohair/felt which covers run channel. Includes adhesive backing. Repairs both sides, Channel not

included.  
Rear Vertical Glass Run Repair Kit  
64-66 ..... CSZZ-6521508-RK

**STRIKER ASSEMBLY**

Original factory type striker. Includes attaching parts.  
Striker Assembly



64-66: Gold zinc, Date coded 1-65  
C20Z-6222008-B



67-70: Silver zinc, date coded 8-66  
CSAZ-6222008-A

**Striker Assembly**



68-70: Silver zinc, date coded 11-67  
CSAZ-6222008-B



71-80: Silver zinc  
D2AZ-6522008-A

**STRIKER PLATE SCREW**



Gold cadmium plated screws to attach door strikers.

**Striker Plate Screw**

64-70 Set of 4 ..... 378428-5

**TOP VENT WINDOW SEAL**



Made from compression molded E.P.D.M. rubber with cadmium plated steel inserts molded inside. Includes rivets. Sold

in sets.

**Top Vent Window Seal**

64-66 ..... CSZZ-6521774/5A

**VENT SEAL EDGE RIVET**



Correct black oxide semi-tubular rivet.

**Vent Seal Edge Rivet**

64-66 Set of 10 ..... 351603-5

**VENT WINDOW BRACKET**



Bracket with shaft to tighten up loose handles.

**Vent Window Bracket**

64-66 Right hand ..... CSZZ-6521608-RK  
64-66 Left hand ..... CSZZ-6521609-RK

**FRONT DOOR GLASS RUN CHANNEL**



Vertical channel which runs behind vent window that door glass slides in. Features original type mohair inside channel,

mounting bracket and stainless steel trim.

**Door Glass Run Channel, Front**

64-66 USA ..... CSZZ-6521538/9A  
64-66 Import ..... CSZZ-6521538/9I  
64-66 Import, right hand ..... CSZZ-6521538-A  
64-66 Import, left hand ..... CSZZ-6521539-A

**FRONT DOOR GLASS RUN INSERTS**

Insert to replace worn rubber and felt channel guide for door glass. Features original looking felt. Top molded pieces are bonded securely and has steel inserts for added strength.

**Door Glass Run Inserts, Front**



67-68  
C7ZZ-6521546/7A



69-70: Left hand  
C9ZZ-6521547-A

69-70: Right hand  
C9ZZ-6521546-A

**REAR VERTICAL GLASS RUN REPAIR KIT**

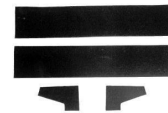

Original type style mohair/felt which covers run channel. Includes adhesive backing. Repairs both sides, Channel not included.

64-66 Right hand ..... CSZZ-6521508-RK

**REAR VERTICAL GLASS RUN ASSEMBLY**



Now available by Scott Drake, this vertical Steel Channel is covered in a Mohair/Felt material mounted in the rear section of the door. It allows

the window to travel up and down easily within the door while keeping Window Glass securely positioned. Commonly rusted and/or with worn out material. (Right hand side.)

64-66 RH ..... CSZZ-6521508-A  
64-66 LH ..... CSZZ-6521509-A  
67-68 RH ..... C7ZZ-65222A36-R

67-68 LH .....C7ZZ-65222A37-L

**WINDOW GUIDE**



Prevent the glass from rattling in the door. Available in white ABS plastic and 16 are required for each car.

69-70 Window Guide .....C9ZZ-6521496

**VENT WINDOW CHANNEL**



Steel channel with door glass run insert installed.

**Vent Window Channel**

67-68 Right hand .....C7ZZ-6521538-A

67-68 Left hand .....C7ZZ-6521539-A

**VENT WINDOW DIVISION BAR SEAL**

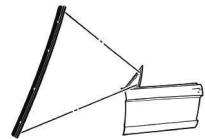

Offers a perfect fit with a steel insert molded into high quality E.P.D.M. rubber. Mounts on back side of vent window bar. Now

original type rivets included.

**Vent Window Division Bar Seal**

64-66 .....CSZZ-6521450-A

**VENT WINDOW FRAME**



Die cast construction with good chrome plating.

**Vent Window Frame**

64-66 Left hand .....C5ZZ-6522204-L

64-66 Right hand .....C5ZZ-6522204-R

67-68 Left hand .....C7ZZ-6522204-L

67-68 Right hand .....C7ZZ-6522204-R

**VENT WINDOW FRAME AND GLASS ASSEMBLY**



Complete vent and window assembly. Includes vent frame, vent glass, vent glass frame and pivot assembly, vent seals, and door glass run. The 1968 version will fit

1967, but vent handle is not concurs correct.

64-66 Right Hand, clear .....C5ZZ-65222404CK

64-66 Right Hand, tinted ....C5ZZ-65222404TK

64-66 Left Hand, clear .....C5ZZ-65222405CK

64-66 Left Hand, tinted .....C5ZZ-65222405TK

68 Right Hand, clear .....C8ZZ-65222404CK

68 Right Hand, tinted ....C8ZZ-65222404TK

68 Left Hand, clear .....C8ZZ-65222405CK

68 Left Hand, tinted .....C8ZZ-65222405TK

**VENT WINDOW FRAME TO DOOR SEAL**

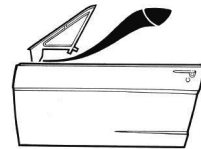

Seals between chrome vent frames and door on exterior side.

**Vent Window Frame To Door Seal**

67-68 .....C60Z-6322280

**VENT WINDOW GLASS FRAME**



Complete chrome plated vent window frame with pivots and vent handle. Glass not included.

**Vent Window Glass Frame**

65-66 Right hand .....C5ZZ-6521608-A

65-66 Left Hand .....C5ZZ-6521609-A

67 Right hand .....C7ZZ-6521608-A

67 Left hand .....C7ZZ-6521609-A

**VENT WINDOW GLASS FRAME AND GLASS**



Chrome plated vent window glass frame with pivot and glass. Will fit 1968, but comes with 1967 vent window handle

attached.

**Vent Window Glass Frame and Glass**

67 Right Hand, clear .....C7ZZ-6521608-CK

67 Right hand, tinted ....C7ZZ-6521608-TK

67 Left hand, clear .....C7ZZ-6521609-CK

67 Left hand, tinted .....C7ZZ-6521609-TK

**VENT WINDOW HANDLE**

Our vent handles are cast from our own tooling with a great chrome finish. Our nylon tips will not scratch the vent frame. Sold as a matched pair. Fits several Ford models. Roll

pins included.

**Vent Window Handle**



64-66  
C30Z-6222916/7A



67  
C60Z-6522916/7A



68  
C80Z-5422916/7B

**VENT WINDOW SEAL**



Our high quality Scott Drake reproduction vent seals offer your customers the finest molded rubber pieces available.

**Vent Window Seal**

64-66 Right hand and left hand .....CSZZ-6521448/9B

64-66 Right hand .....C5ZZ-6521448-B

64-66 Left hand .....C5ZZ-6521449-B

67-68 Right hand .....C7ZZ-6521448-AR

67-68 Left hand .....C7ZZ-6521449-AR

**VENT WINDOW SEAL KIT**



Convenient time saving kit offers you everything to complete vent seal installation. Kit features vents seals, top vent

seals, back edge vent seals, and all rivets. Check out our rivet tools to make the job easier.

**Vent Window Seal Kit**

64-66 .....KIT-RUB-5

**VENT WINDOW TO DOOR SEAL**

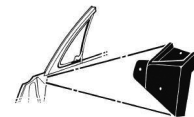

These high quality vent window seals are the first on the market to replace the original Ford part exactly. This is the small seal

at the front of the door and next to the door weatherstrip.

**Vent Window To Door Seal**

67-68 .....C7ZZ-6522332/3

Door Parts

**WE PROUDLY FEATURE AUTHENTIC MUSTANG REPRODUCTIONS FROM SCOTT DRAKE ENTERPRISES!**



## WEATHER STRIP ADHESIVE



Super strong weatherstrip adhesive for installing door and trunk seals. From 3M. Supplied in five ounce tubes. Cannot be

shipped by air.

### Weather Strip Adhesive

- 64-73 Yellow, not for EPDM rubber ... 3M-8001
- 64-73 Black, not for EPDM rubber ..... 3M-8008
- 64-73 Black, for EPDM rubber ..... 3M-8011

## DOOR WEATHER STRIPPING

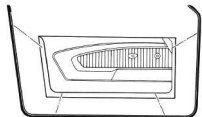

Made from the finest E.P.D.M. rubber, these sponge extrusions have transfer molded ends like the originals. These are not glued

and feature the correct cross section and size for proper sealing. Includes original looking mounting fasteners.

### Weather Stripping, Door

- 64-66 Door ..... CSZZ-6520530/1A
- 67-68 Door ..... C7ZZ-6520530/1A
- 69-70 Door ..... C9ZZ-6520530/1A
- 71-73 Door ..... D1ZZ-6520530/1A

## DOOR BOTTOM WEATHER STRIPPING

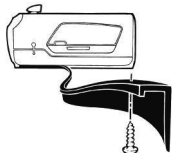

This seal cuts down wind and road noise. attaching hardware included.

### Weather Stripping, Door Bottom

- 69-70 Door Bottom ..... C9ZZ-6520272-A

## WINDOW & ROOFRAIL SEAL CLIP



Stamped steel with molded black vinyl, mounts on roofrail. Helps to hold weatherstrip and guides window glass. 4

required per car.

### Window & Roofrail Seal Clip

- 69-70 Coupe and Fastback ..... C9ZZ-6522204

## CONCOURS WINDOW CHANNEL STRIPS



We proudly carry the full line of Re-Pops window channel strips. Rest assured that these are the highest quality on the market.

These window channel strips have the correct

bends and staples. They also come with easy to understand instructions and a drill bit for installation. Made in the U.S.A.

### Window Channel Strips, Concourse

- 65-66 Fastback ..... CSZZ-6321458/9S
- 65-66 Coupe and convertible C5ZZ-6521458/9S
- 67-68 Fastback ..... C7ZZ-6321458/9S
- 67-68 Coupe ..... C7ZZ-6521458/9S
- 67-68 Convertible ..... C7ZZ-7621458/9S
- 69-70 Fastback ..... C9ZZ-6321458/9S
- 69-70 Coupe ..... C9ZZ-6521458/9S
- 69-70 Convertible ..... C9ZZ-7621458/9S
- 71-73 Fastback ..... D1ZZ-6321458/9S
- 71-73 Coupe ..... D1ZZ-6521458/9S
- 71-73 Convertible ..... D1ZZ-7621458/9S

## ECONOMY WINDOW CHANNEL STRIPS



These feature narrow outer strips rather than concourse wide outer strips. Good alternative for daily drivers.

### Window Channel Strips, Economy

- 64-66 Coupe and convertible, economy ..... CSZZ-6521458/9E
- 65-66 Fastback, economy ..... CSZZ-6321458/9E

## QUALITY IMPORT WINDOW CHANNEL STRIPS



These are a great alternative for those on a budget compared to our premium U.S.A. version. More like originals than our

economy versions, listed below.

### Window Channel Strips, Quality Import

- 64-66 Coupe/Convertible ..... CSZZ-6521458/9R
- 65-66 Fastback ..... CSZZ-6321458/9R
- 67-68 Fastback ..... C7ZZ-6321458/9R
- 67-68 Coupe ..... C7ZZ-6521458/9R

## WINDOW SEALER



Used to water-proof windshield and rear window. Silicone type sealer is best suited for glue in windshields. Non-hardening version

also works well on retaining watershields.

### Window Sealer

- 64-73 Non-hardening ..... CRL-7708
- 69-73 Silicone based ..... 3M-8606

## WINDOW REGULATORS AND COMPONENTS

### DOOR GLASS ASSEMBLY



This door glass includes the frame, glass run and mounting bracket. Available in clear glass or factory green tint. For replacement glass only, see windows section.

**Tinted versions available Summer 2012.**

- 67-68 Fastback, LH, clear C7ZZ-6321410-KL
- 67-68 Fastback, RH, clear C7ZZ-6321410-KR
- 67-68 Coupe, LH, clear C7ZZ-6521410-KL
- 67-68 Coupe, RH, clear C7ZZ-6521410-KR
- 67-68 Conv, LH, clear C7ZZ-7621410-KL
- 67-68 Conv, RH, clear C7ZZ-7621410-KR
- 67-68 Fastback, LH, tint C7ZZ-6321410-TL
- 67-68 Fastback, RH, tint C7ZZ-6321410-TR
- 67-68 Coupe, LH, tint C7ZZ-6521410-TL
- 67-68 Coupe, RH, tint C7ZZ-6521410-TR
- 67-68 Conv, LH, tint C7ZZ-7621410-TL
- 67-68 Conv, RH, tint C7ZZ-7621410-TR

### DOOR GLASS BUMPER



Rubber bumper that installs inside the bottom of the door that stops the travel of door glass. One required per door,

snaps into place.

### Door Glass Bumper

- 64-70 Lower ..... CSZZ-6521762

### WINDOW GROMMET



Protects door glass when attaching window channel. Bolt on glass only. Grommet pictured.

- 69-70 Window Grommet ..... C9ZZ-6523258-B
- 69L-70 Window Guide Bushing ..... C9ZZ-6323266

### DOOR WINDOW REGULATOR



'64-'66 version

### Window Regulator, Door

- 64 Concourse, right hand ... CSZZ-6523202-A
- 64 Concourse, left hand ..... CSZZ-6523203-A

**Window Regulator, Door**

65-66	Concours, right hand ...	C5ZZ-6523202-B
65-66	Concours, left hand .....	C5ZZ-6523203-B
67	Concours, right hand .	C7ZZ-6523200-AR
67	Concours, left hand ...	C7ZZ-6523201-AR
68	Concours, right hand .	C8ZZ-6523200-AR
68	Concours, left hand ...	C8ZZ-6523201-AR
69	Right hand .....	C9ZZ-6523200-AR
69	Left hand .....	C9ZZ-6523201-AR
70	Right hand .....	D0ZZ-6523200-AR
70	Left hand .....	D0ZZ-6523201-AR
71-73	Right hand .....	D1ZZ-6523200-A
71-73	Left hand .....	D1ZZ-6523201-A

**UNIVERSAL DOOR WINDOW REGULATOR**



Good quality universal style fits both screw on and clip on style window cranks. Same high quality as our concours regulators

but with a specially designed shaft that will fit both styles of cranks. 1 year warranty.

**Window Regulator, Universal Door**

64-66	Universal, right hand ....	C5ZZ-6523202-E
64-66	Universal, left hand .....	C5ZZ-6523203-E

**WINDOW REGULATOR RETAINER CLIP**



Secures window regulator to scissor mechanism.

**Window Regulator Retainer Clip**

64-66	.....	353745-S
-------	-------	----------

**WINDOW REGULATOR SCISSOR ASSEMBLY**



Very nice copy of scissor assembly that allows door glass to move up and down.

**Window Regulator Scissor Assembly**

64-66	Left hand .....	C5ZZ-6523234-L
-------	-----------------	----------------

**Window Regulator Scissor Assembly**

64-66	Right hand .....	C5ZZ-6523234-R
-------	------------------	----------------

**WINDOW ROLLER & CLIP**



Used on door and quarter window regulators scissors. Replacement makes window glass move easier.

**Window Roller & Clip**

64-68	.....	C0AB-6423240-B
-------	-------	----------------

**QUARTER WINDOW REGULATOR**



Cadmium plated to prevent rust. Engineered for a perfect fit. Will not self destruct like others.

**Window Regulator, Quarter**

64-67	Left hand .....	C5ZZ-6530306-L
64-67	Right hand .....	C5ZZ-6530306-R
68	Left hand .....	C8ZZ-6530306-L
68	Right hand .....	C8ZZ-6530306-R
69-70	Left hand .....	C9ZZ-6530306-L
69-70	Right hand .....	C9ZZ-6530306-R
71-73	Left hand .....	D1ZZ-6530306-L
71-73	Right hand .....	D1ZZ-6530306-R

**ELECTRICAL & LIGHTING ELECTRICAL REFERENCE BOOKS**

**WIRING DIAGRAM MANUAL**



Covers a multitude of electrical pictorial diagrams, color codes are listed, plus easy to follow schematics.

**Wiring Diagram Manual**

64	.....	MP-312
65	.....	MP-1
66	.....	MP-2
67	.....	MP-3
68	.....	MP-4
69	.....	MP-5
70	.....	MP-6
71	.....	MP-7
72	.....	MP-8
73	.....	MP-9

**LARGE FORMAT WIRING DIAGRAM MANUAL**



Covers a multitude of electrical pictorial diagrams, color codes are listed, plus easy to follow schematics. Our large format features

larger diagrams that are easier to read.

**Wiring Diagram Manual, Large Format**

64	.....	MP-311-P
65	.....	MP-1-P
66	.....	MP-2-P
67	.....	MP-3-P
68	.....	MP-4-P
69	.....	MP-5-P
70	.....	MP-6-P
71	.....	MP-7-P
72	.....	MP-8-P
73	.....	MP-9-P

**FOG LIGHTS**

**G.E. FOG LIGHT BULB**

Features original GE logo and 'fog' script on lens

**Fog Light Bulb, G.E.**



65-68: Clear  
FDU-15220-A



65-68: Amber  
FDU-15220-AMBER

**FOG LIGHT HOUSING ASSEMBLY**

These Fog Light Housing Assemblies are the best on the market. Assemblies include triple chrome-plated rims, silver painted housings on back, an exact copy of the wiring harness, cup mounting washer, and serrated flange nut. They also feature the correct wire exit and drain hole. Bulb not included.

**Fog Light Housing Assembly**



65-67: Concours correct  
CSRZ-15200-A



68: Without correct wire pigtail  
C8ZZ-15200-A

Electrical

**WE PROUDLY FEATURE AUTHENTIC MUSTANG REPRODUCTIONS FROM SCOTT DRAKE ENTERPRISES!**





**Fog Light Housing Assembly**



68: Blue plug, concurs correct  
C8ZZ-15200-AC



68: w/out crossbar, w/out correct  
wire pigtail  
C8ZZ-15200-SPEC

**TRI-BAR FOG LIGHT HOUSING ASSEMBLY**



These 4" fog lamps feature our quality fog light housings, beautiful chrome bezels, and include an internal chrome, tri-bar

design. The perfect match to our larger, tri-bar headlights.

**Fog Light Housing Assembly, Tri-Bar**

64-67 ..... C5ZZ-15200-TB

**FOG LIGHT HOUSING RIM**



For customers who wish to restore their own housings, these perfect reproductions feature triple chrome plating and an exact

fit.

**Fog Light Housing Rim**

65-68 With bar ..... C5ZZ-15214-A

65-68 Without bar ..... C5ZZ-15214-SPEC

**FOG LIGHT SWITCH**

Nice reproduction of original part, which duplicates the factory wiring pigtail, bezel and knob

**Fog Light Switch**



65: Factory plug for original 65 GT cars only  
C5ZZ-15A214-A



65-66: Complete with pigtail  
C6ZZ-15A214-A



67  
C7ZZ-15A214-A



68  
C8ZZ-15A214-A

**FOG LIGHT WIRING CIRCUIT BREAKER**



Mounts under dash, controls voltage for wire protection. Includes primary wire which connects to Headlamp Switch Plug.

Instructions included.

**Fog Light Wiring Circuit Breaker**

65-68 ..... C5ZZ-15223-CB

68 ..... C8ZZ-14448-F

**FOG LIGHT WIRING CONVERSION KIT**



Everything you need to hook up your fog lights. Kits feature correct colored connectors and include circuit breaker.

(Fog light switch sold separately).

**Fog Light Wiring Conversion Kit**

64-65 Instrument warning light cars ..... C5ZZ-15223-FUD

66-67 All non GT cars ..... C6ZZ-15223-FUD

68 ..... C8ZZ-15223-FUD

**FOG LIGHT WIRING FEED**



Hot wire from fog light under-dash harness to fog light housing pigtail. Connects left and right fog light.

1965 GT cars originally

had this feed wrapped into the headlight harness.

**Fog Light Wiring Feed**

64-65 Warning light cars ..... C5ZZ-15223-FH

66-67 GT and non GT cars ..... C6ZZ-15223-FH

68 With correct blue plugs ..... C8ZZ-15223-UHH

**FOG LIGHT WIRING GROUND**



All black wire which plugs into fog lamp pigtail and grounds to radiator support.

**Fog Light Wiring Ground**

65-68 ..... C5ZZ-15223-GR

**FOG LIGHT WIRING PIGTAIL**



Pigtail wires which connect to bulb and run through housings and plug into fog light feed. Not necessary if purchasing fog lamp

housings as pigtails are included.

**Fog Light Wiring Pigtail**

64-67 Correct connectors ..... C5ZZ-15223-FGPT

68 Correct blue plug ..... C8ZZ-15223-FGPT

**FOG LIGHT WIRING UNDER-DASH HARNESS**



Correct color coded wiring for fog lights.

**Fog Light Wiring Under-Dash Harness**

65 ..... C5ZZ-15223-UDH

66 ..... C6ZZ-15223-UDH

67 ..... C7ZZ-15223-UDH

68 ..... C8ZZ-15223-UDH

69 Shelby ..... S9MS-15223-A

**HEADLIGHTS**

**GRILLE CORRAL LED LIGHT KIT**



Add some flair to the front of your Mustang with a Grille Corral that lights up. Our kits work with your existing 1964-67 Corral

and Running Horse emblem. Kits include back reflector panel, waterproof LED modules, and electrical connectors. Simple installation with flexible wiring options. Grille Corral and Horse available separately from Scott Drake (part #'s C5ZZ-8213-AR, C6ZZ-8213-A, & C7ZZ-8213-A).

**Grille Corral LED Light Kit**

64-65 ..... C5ZZ-8213-LED

66 ..... C6ZZ-8213-LED

67 ..... C7ZZ-8213-LED

**TRI-BAR HEADLIGHT**



Beautiful chrome internal tri-bar design. Great custom look!

**Headlight**

64-73 High performance, Tri bar ..... C5ZZ-13007-CLR

64-73 High performance, Tri bar, blue ..... C5ZZ-13007-LBB

**HIGH PERFORMANCE HEADLIGHT**



These headlamps are made by Delta Tech a premier European manufacturer in automotive lighting equipment. Features prismatic lead crystal lens. Replaceable

halogen or Xenon 60/55 watt bulbs, four coating finish parabolic reflectors, E-Mark certified optics with precise photometrics. In english that means they really light up the night. The City Lights option includes additional low watt bulbs that can be used either as a daytime running light or as an evening parking light. Wiring harness is sold separately for City lights option.

**Headlight**

- 64-73 High performance, Euro .. CSZZ-13007-H
- 64-73 High performance, Xenon CSZZ-13007-X
- 64-73 High performance, Xenon with city lights\* ..... CSZZ-13007-XCL
- 69 Xenon, high beam ..... C9ZZ-13007-XH
- 69 Xenon, high and low beam ..... C9ZZ-13007-XHL

requires City Light Wiring Harness Kit CSZZ-13007-CLH

**FoMoCo HALOGEN HEADLIGHT**

**NOW AVAILABLE!**

Now available from Scott Drake, FoMoCo Halogen Headlamps featuring authentic Ford markings and upgraded Halogen

performance. This is a reproduction of a very desirable and rare version headlamp used on Classic Mustangs. We took NOS new original Ford bulbs and duplicated them in appearance while improving them with Halogen lighting technology. Halogen headlamps produce more than double the lighting power of original Tungsten bulbs. Perfect for drivers or trailer queens, a great safety improvement while maintaining an original look. Over the years Ford offered two FoMoCo script versions: one sand blasted etched logo, and the other a prominent reverse raised FoMoCo logo about 7/8" wide. We chose to reproduce the rare, highly sought reverse raised logo version, which is more attractive and easier to read. Approved by Ford as an "Official Licensed Product".

**Headlight Adjusters**

- 64-73 (except 1969) ..... CODZ-13007-A

**HEADLIGHT ADJUSTERS**



**Headlight Adjusters**

- 69 ..... C9AZ-13032-A

**HEADLIGHT ASSEMBLY HARDWARE**

**KIT**



A complete kit to mount a headlight assembly to the fender, everything you need. Sold each, it takes two per car.

**Headlight Assembly Hardware Kit**

- 64-66 ..... CSZZ-13008-MK
- 67-68 ..... C7ZZ-13008-MK
- 69 1 side (2 kits required per vehicle) ..... C8AZ-13118/9-MK

**HEADLIGHT BUCKET**



Headlight bucket, painted black, no hardware.

**Headlight Bucket**

- 64-66 Right hand or left hand ... CSZZ-13008-A
- 67-68 Right hand ..... C7ZZ-13008-A
- 67-68 Left hand ..... C7ZZ-13008-B
- 69 Right hand - Inner ..... C8AZ-13118-A
- 69 Right hand - outer ..... C8AZ-13118-B
- 69 Left hand - Inner ..... C8AZ-13119-A
- 69 Left hand - outer ..... C8AZ-13119-B
- 70 Right hand ..... D0ZZ-13118-A
- 70 Left hand ..... D0ZZ-13119-A

**HEADLIGHT BUCKET ASSEMBLY**



Reproduction headlight bucket assembly. Kit contains mounting hardware.

**Headlight Bucket Assembly**

- 65-66 Right hand ..... C5ZZ-13008-CR
- 65-66 Left hand ..... C5ZZ-13008-DR
- 67-68 Right hand ..... C7ZZ-13008-CR
- 67-68 Left hand ..... C7ZZ-13008-DR
- 69 Right hand ..... C9ZZ-16018-R
- 69 Left hand ..... C9ZZ-16019-L
- 70 Right hand ..... D0ZZ-16018-R
- 70 Left hand ..... D0ZZ-16019-L

**HEADLIGHT DIMMER SWITCH**



This quality after-market dimmer switch matches the original nicely. Imported. Note: Electrical parts are not returnable.

**Headlight Dimmer Switch**

- 64-78 Imported ..... C0TZ-13A024-A

**HEADLIGHT DOOR**

Die cast headlight door which fits on the headlight assembly. Primered.

**Headlight Door**



- 65-66: Left hand CSZZ-13064-A



- 65-66: Right hand CSZZ-13064-B



- 67-68: Primered C7ZZ-13064-A



- 67-68: Chrome, both sides w/ chrome screws C7ZZ-13064-C



- 69: Outer, chrome C9ZZ-13064-A



- 69: Inner C9ZZ-13064-B/C



- 70 D0ZZ-13064-A/B

**HEADLIGHT RETAINING RING**

Headlight ring features, high-quality, stamped steel construction.

**Headlight Retaining Ring**



- 64-73: does not fit 69 Mustang D3TZ-13015-A



- 69 C7AZ-13015-B

**HEADLIGHT SWITCH**



Quality imported switches at affordable prices.

**Headlight Switch**

- 64 Generator ..... CSZZ-11654-C

Electrical

**WE PROUDLY FEATURE AUTHENTIC MUSTANG REPRODUCTIONS FROM SCOTT DRAKE ENTERPRISES!**



### Headlight Switch

65-68	.....C5ZZ-11654-BR
69	.....C9ZZ-11654-AR
70	.....D0ZZ-11654-A
71-72	.....D3ZZ-11654-A

### HEADLIGHT SWITCH BEZEL

New, chrome bezels really make a freshly painted dash pop. Beautiful reproductions. Headlight Switch Bezel



64-66  
C4DZ-10852-B



67-68  
C7ZZ-10852-A



69-70  
C9ZZ-10852-L

### HEADLIGHT SWITCH COVER



Molded rubber cover which fits over headlight dimmer switch.

### Headlight Switch Cover

65-73 .....C5ZZ-13533

### HEADLIGHT SWITCH KNOB

Knob is die-cast zinc, chrome plated with very good detail. Switch shaft is zinc plated to prevent rust or corrosion.

### Headlight Switch Knob



64  
C4ZZ-11661-A



65-66  
C5ZZ-11661-B



67-68  
C7ZZ-11661-A



69-70  
C9ZZ-11661

### HEADLIGHT SWITCH RETAINING

#### NUT



Beautiful chrome retaining nut that holds headlight switch into the dash. These were previously difficult to find. Made

from original factory prints.

### Headlight Switch Retaining Nut

65-66	.....C5ZZ-11650-A
67-68	.....C7ZZ-11650-A

### HEADLIGHT WIRING GROMMET



Snaps into LH Fender Apron to prevent Headlight Harness from being damaged.

### Headlight Wiring Grommet

65-66 .....C5ZZ-14603-H

### HEADLIGHT WIRING HARNESS



Connects to firewall near master cylinder and runs along driver side inner fender apron and across radiator support.

Connects headlights, (1967 - 70 do not include headlamp extension).

### Headlight Wiring Harness

64	.....C4ZZ-14290-ALL
65	With gauges and fog lamps .....C5ZZ-14290-WG
65	With warning lamps ....C5ZZ-14290-WL
66	With gauges .....C6ZZ-14290-ALL
67	Without tachometer, without GT .....C7ZZ-14290-A
67	Without tachometer, with GT .....C7ZZ-14290-B
67	With tachometer, without GT .....C7ZZ-14290-C
67	With tachometer, with GT C7ZZ-14290-D
68	Without tachometer, without GT .....C8ZZ-14290-A
68	Without tachometer, with GT .....C8ZZ-14290-B
68	With tachometer, without GT .....C8ZZ-14290-C
68	With tachometer, with GT C8ZZ-14290-D
69	Without tachometer .....C9ZZ-14290-A
69	With tachometer .....C9ZZ-14290-B
70	Without sport lights .....D0ZZ-14290-A
70	With sport lights .....D0ZZ-14290-B
70	Mach 1, with sports lights after 10-15-69 D0ZZ-14290-L

### CITY LIGHT HEADLIGHT WIRING

#### HARNESS



This harness kit is required with the Xenon headlamps with "City Lights" option.

### Headlight Wiring Harness, City Light

64-73 Xenon headlamps .....C5ZZ-13007-CLH

### HEADLIGHT WIRING HARNESS

#### EXTENSION



Concours correct. Attaches to headlight harness and connects to seal beam.

### Headlight Wiring Harness Extension

67-68	.....C7ZZ-13076-EXT
69	.....C9ZZ-13076-EXT
70	.....D0ZZ-13076-EXT

### HEADLIGHT WIRING RELAY

#### HARNESS



Tired of flickering headlamps, especially when you are running Halogen or other high-performance headlamps? This

Headlamp Relay Harness will eliminate that problem forever! Our easy-to-install relay will improve the performance of your headlamps, giving you better night vision. Includes installation instructions for classic Mustangs, but this relay can also be used in all Ford products from the same era.

### Headlight Wiring Relay Harness

64-73 .....C5ZZ-14290-RH

### HEADLIGHT "ON" WARNING

#### BUZZER



The Scott Drake headlight "ON" warning buzzer is designed to activate when either the parking lights or head

lights are left on after the ignition is turned off. This is a easy to install kit using quick splice connectors. No permanent alterations to the car's wiring are required. Includes instructions for 1965-67 Mustang's, however our warning buzzer kit can also be adapted to fit other makes and models of cars.

### Warning Buzzer, Headlight "On"

65-70 .....C6AZ-14931-AR

## HOOD TURN SIGNALS

### COWL-HOOD GROUNDING STRAP



This piece is an exact reproduction. Brass contact strap with correct mounting screw.

Cowl-Hood Grounding Strap  
67-68 .....CSAA-18870-A

### HOOD TURN SIGNAL HARNESS



Connects both L.H. and R.H. turn signal lamps, plugs into firewall harness. Includes sockets.

Hood Turn Signal Harness  
67-68 .....C7ZZ-13A357-TSH  
69-70 .....C9ZZ-13A357-TSH

### HOOD TURN SIGNAL LIGHT ASSEMBLY

A nice reproduction. Includes lens seal.  
Hood Turn Signal Light Assembly



67-68  
C7ZZ-13A355-B-



69-70  
C9ZZ-13A355-A

### SEQUENTIAL HOOD TURN SIGNAL LIGHT ASSEMBLY



These upgraded Sequential Turn-Signal Hood Lights now feature SMD LED's. Exclusively designed for the turn signals in

the back of the hood scoop. White led lamps produce highly visible light, even in daylight. Features "plug in and go" simplicity. Works with or without our sequential tail light kit.

Hood Turn Signal Light Assembly, Sequential  
67-68 .....C7ZZ-SHL  
69-70 .....C9ZZ-SHL

## INTERIOR ELECTRICAL

### CLOCK FEED WIRE



Correct feed wire for the clock.

Clock Feed Wire  
69-70 .....C9ZZ-15A006-CL

### CONSOLE HARNESS FEED



This harness supplies power to the console. Comes from under dash harness and runs underneath carpet, exits at carpet shifter

hole location.  
Console Harness Feed  
64-66 Dash to console .....C5ZZ-13B712-A  
68 Shelby, dash to console S8MS-13B712-A  
69 Dash to console .....C9ZZ-13B712-A

### CONSOLE INTERIOR HARNESS



This harness plugs into console harness feed. Operates rear courtesy lights and front storage compartment on non AC cars.

Console Interior Harness  
64-66 Without air conditioner C5ZZ-13B711-LG  
64-66 With air conditioner ...C5ZZ-13B711-SM

### CONSOLE INTERNAL HARNESS



This harness supplies power to the console. Comes from under dash harness and runs underneath carpet, exits at carpet shifter

hole location.  
Console Internal Harness  
64-66 Dash to console .....C5ZZ-13B712-A

### CONSOLE LAMP LENS



Fits on the rear of the console. Original white plastic color.

Console Lamp Lens  
64-66 .....C5ZZ-13734-A  
67-68 .....C7ZZ-13783-A

### CONSOLE REAR LAMP ASSEMBLY



Good quality reproduction part, features white plastic lens and pressure die cast body with excellent chrome on

the bezel.  
Console Rear Lamp Assembly  
65-66 .....C5ZZ-13707-A  
67-68 .....C7ZZ-13707-A

### CONVERTIBLE TOP HARNESS



This is the main harness for the power convertible top. Made in the U.S.A.

Convertible Top Harness  
64-68 Concours for 64-66 .....C5ZZ-7615A668  
67-68 Concours for 67-68 .....C7ZZ-7615A668  
64-66 Underhood Feed .....C4DZ-15668-B

### COURTESY LIGHT HARNESS



For deluxe interior cars with door lights and/or door speakers.

Courtesy Light Harness  
64-66 Without speakers .....C5ZZ-13A769-A  
66 With speakers .....C6ZZ-13A769-A  
67-68 With speakers .....C7ZZ-13A769-A  
69-70 With speakers .....C9ZZ-13A769-A

### DOME LIGHT ASSEMBLY



We made a bright chrome base with a brighter than original bulb to really improve lighting inside the car. We include

instructions on how to easily add this dome lamp to earlier Mustangs that didn't have this feature. Our dome light assembly can even be mounted up under the back deck to make a great trunk light. Our reproduction dome lens and chrome bezel as well as the mounting hardware and electrical connectors are included to make this a quick and simple project.

Dome Light Assembly  
65-70 .....C0AF-13A719-B

### LED DOME LIGHT ASSEMBLY



Kit comes complete with housing, hardware, and modern, smart LED module! This dome light is 5x brighter and automatically dims after 10 minutes, and turns

**WE PROUDLY FEATURE AUTHENTIC MUSTANG REPRODUCTIONS FROM SCOTT DRAKE ENTERPRISES!**



off after 15 minutes. Lifetime warranty!  
**Dome Light Assembly, LED**  
 64-70 .....SD-DOME-LED-WH

### DOME LIGHT HOUSING

Housing is chromed plastic.  
**Dome Light Housing**



67-70  
 COAF-13788-A



71-73: Includes bulb  
 D6UZ-13788-A

### DOME LIGHT LENS

High quality injection molded parts, exactly like the originals. Lens is milk white.  
**Dome Light Lens**



67-70  
 COAF-13783-C



71-73  
 D1AZ-13783-B

### DOOR SPEAKER CROSSOVER HARNESS

Connects door harnesses to radio.

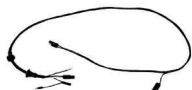

**Door Speaker Crossover Harness**  
 66-70 .....C6ZZ-13A770-A

### FUSE BOX REPAIR KIT



New clips to replace loose or corroded fuse holders. Contains eight clips.

**Fuse Box Repair Kit**  
 64-68 ..... FUSE CLIPS

### INSTRUMENT CLUSTER LOOM

Features correct color codes.



**Instrument Cluster Loom**  
 67 With tachometer .....C7ZZ-10B942TACH

### Instrument Cluster Loom

67 No tachometer .....C7ZZ-14401-ICF  
 68 With tachometer .....C8ZZ-10B942TACH  
 68 No tachometer .....C8ZZ-14401-ICF

### PRINTED INSTRUMENT PANEL CIRCUIT



Great product, this is a complete printed circuit to eliminate those dash electrical problems.

**Instrument Panel Circuit, Printed**  
 69-70 Without tachometer .....C9ZZ-10K843-A

### INSTRUMENT PANEL LED LIGHTS



Finally see your gauges at night with cool-running, lifetime LED's. 4x brighter than old incandescent lights! Each kit is warranted

for the life of your car, and includes gauge illumination lights (blue), turn signal indicator lights (white), and high-beam light (white/red). These kits use your existing gauges, you just replace the bulbs! Lifetime warranty!

### Instrument Panel LED Lights

64-66 Long Speedometer .....SD-6456-GA-BL  
 65-66 5-Gauge Cluster .....SD-66-GA-BL  
 67-68 .....SD-6768-GA-BL  
 69-70 .....SD-6970-GA-BL  
 71-73 .....SD-7173-GA-BL  
 64-68 White 1895, set of 4 .....SD-1895  
 64-68 Blue 1895, set of 4 .....SD-1895-BL

### INSTRUMENT VOLTAGE REGULATOR



From Scott Drake, these Instrument Voltage Regulators feature an improved design to be more reliable and accurate in varying environments (heat, humidity, etc...). Features solid state electronic circuitry and variable control. Preset to factory specifications but adjustable to fine-tune your gauges. **69-70 will be available late Spring 2012.**

64-66 B9MZ-10804-EADJ  
 67-68 C6DZ-10804-EADJ  
 69-73 C9AZ-10804-EADJ

### INTERIOR LED LIGHTS



Convert your Mustang's interior lights to cooler running, brighter LED's. Many ordinary LED's don't work with

classic Mustang lighting circuits, but these are specifically designed to work with your classic Mustang! Lifetime warranty!

### Interior LED Lights

64-66 Standard Interior .....SD-6466-INT-WH  
 64-66 Pony Interior .....SD-6466-INT-WHD  
 67-68 .....SD-6768-INT-WH

### NEUTRAL SAFETY SWITCH HARNESS



### Neutral Safety Switch Harness

64-65 .....C5ZZ-7A240-NS  
 66 .....C6ZZ-7A240-NS

### OVERHEAD CONSOLE ASSEMBLY



A beautiful reproduction of a rare option. The console base is made of vinyl and urethane with exact details. We

have installed our maplight switch and light housing with our beautiful chrome bezels. Includes wiring harness and mounting screws. Mounting brackets available separately, please refer to the "Interior" section..

### Overhead Console Assembly

67 Fastback, black .....C7ZZ-63519A58BK  
 67 Fastback, blue .....C7ZZ-63519A58BL  
 67 Fastback, ivy gold .....C7ZZ-63519A58IG  
 67 Fastback, parchment C7ZZ-63519A58PR  
 67 Fastback, red .....C7ZZ-63519A58RD  
 67 Coupe, black .....C7ZZ-65519A58BK  
 67 Coupe, blue .....C7ZZ-65519A58BL  
 67 Coupe, ivy gold .....C7ZZ-65519A58IG  
 67 Coupe, parchment ....C7ZZ-65519A58PR  
 67 Coupe, red .....C7ZZ-65519A58RD

### OVERHEAD MAP LIGHT SWITCH

Scott Drake has assembled a set of modern switches into his reproduction map light housing to make a easy replacement of old switches. Works as good as it looks.

### Overhead Map Light Switch



67-68: Buttons only  
 C7Z-13764-B



67-68: Switches only  
 C7Z-13764-S

### Overhead Map Light Switch



67-68: Switch and buttons  
C7Z-13764-KIT

### FASTBACK QUARTER PANEL LIGHT



These interior quarter lights are exact copies of the originals. Features include our high quality chrome finish, correct

connector and the flat index to orient the light in the correct position. These are not "one size fits all" like the competition.

#### Quarter Panel Light, Fastback

65-68 Fastback .....C4SZ-13776-B  
69-70 Fastback .....D0AZ-13776-A

### FASTBACK QUARTER PANEL LIGHT

#### LENS

Injection molded white plastic.



#### Quarter Panel Light Lens, Fastback

65-69 .....C1SZ-13783-B

### RED ACCENT LIGHT



Our CCFL light shines red light that will not distract the driver at night but will bring embroidered floor mats to life. We encase

our light in a tough clear plastic housing that can be mounted just about anywhere inside the car. Designed to be used under the dash or under seats, this light can also be mounted in the trunk or temporarily under the hood to show off these areas.

#### Red Accent Light

64-68 Red accent light .....C5Z-13760-RED

### SHIFT INDICATOR LIGHT



A nice reproduction. Features a bright zinc finish for long life. Ford type connectors for quick installation.

#### Shift Indicator Light

65-66 All .....C5Z-15A808-A  
67-68 Without console .....C7Z-15A808-A  
67-68 With console .....C7Z-15A808-B

### UNDER-DASH HARNESS



Includes fuse block, all molded ends and correct color codes. Note: 1965-66 harnesses do not include Wiper Motor

Loom. Refer to Wiper Motor Looms at the end of this section.

#### Under-Dash Harness

64 One speed wiper motor .....

C4Z-14401-1SW

64 Two speed wipers .....C4Z-14401-2SW

65 .....C5Z-14401-WL-2

65 GT or pony interior .....C5Z-14401-WG

65 Three speed heater ...C5Z-14401-WL-3

66 .....C6Z-14401-ALL

67 Standard .....C7Z-14401-STD

67 With tachometer .....C7Z-14401-STD-T

67 GT .....C7Z-14401-GT

67 GT with tachometer ....C7Z-14401-GT-T

68 Standard .....C8Z-14401-STD

68 With tachometer .....C8Z-14401-STD-T

68 With foglamp .....C8Z-14401-STD-F

68 GT with tachometer ....C8Z-14401-GT-T

### AIR CONDITIONER UNDER-DASH

#### HARNESS



Plugs into main A/C unit under dash, connects into back of ignition switch then, runs through firewall to compressor switch.

#### Under-Dash Harness, Air Conditioner

64-66 .....C5Z-19800-ACF

67 .....C7Z-19800-ACF

### SEAT BELT UNDER-DASH

#### REMINDER LIGHT

These lights look exactly like the originals, but feature a state-of-the-art LED light that will not melt the lens like the originals did. The LED light is rated at 100,000 hours & will last for years. This kit comes complete with a timer switch that will turn the light off after a short period of time.

#### Under-Dash Reminder Light, Seat Belt



65-66: Stick on  
C6OZ-10C876-A1



67-68: With bracket  
C7Z-10C876-B

### PARKING BRAKE UNDER-DASH

#### WARNING LIGHT

These lights look exactly like the originals, but feature a state-of-the-art LED light that will not melt the lens like the originals did. The LED light is rated at 100,000 hours & will last for years. This kit comes complete with a switch and bracket assembly to install on the parking brake unit.

#### Under-Dash Warning Light, Parking Brake



64-66: Stick on  
C4DZ-15A852-A1



67-68: With bracket  
C7Z-15A852-A1

### WIPER MOTOR LOOM



Connects to the wiper switch in dash and runs to the under-dash main harness.

#### Wiper Motor Loom

65 Two speed .....C5Z-17B587-WL2

65-66 One speed .....C5Z-17B587-WL1

66 Two speed .....C6Z-17B587-WL2

### INTERIOR ELECTRICAL SWITCHES

#### COURTESY LIGHT SWITCH



White

Available in two finishes! A white finish that is an exact reproduction of the original Ford part, or a new chrome finish. All

our 68-70 switches feature the "Autolite" logo. Note: Our 68-70 versions are the 2 pin type. Many 1970-73 cars used 3 pin type switches for optional door ajar feature.

#### Courtesy Light Switch

64-67 White, bulk .....C3AZ-13713-A

64-67 White .....C3AZ-13713-AK

64-67 Chrome .....C3AZ-13713-ACK

68-70 White with Autolite logo, bulk .....

C8AZ-13713-C

68-70 White with Autolite logo C8AZ-13713-CK

68-70 Chrome with Autolite logo .....

C8AZ-13713-CCK

### COURTESY LIGHT SWITCH SOCKET



The original plastic sockets are very brittle & almost always breaks when installing a new door jamb switch.

Does not fit cars with

door ajar option. Simply install by carefully breaking the old brittle plastic socket apart with pliers, remove, and plug wire leads into the new socket.

#### Courtesy Light Switch Socket

68-73 ..... C8AZ-14489-K

### EMERGENCY FLASHER SWITCH



Switch and bracket for late 1966 Mustangs.

Version without pigtail can also be spliced into early 1966 Mustangs. Early version includes

complete harness.

#### Emergency Flasher Switch

66 without pigtail, for late 1966 ..... C6AZ-13350

### TURN SIGNAL FLASHER

High quality replacement parts, may not appear original. Also used for emergency flashers.

#### Flasher, Turn Signal



65-70: Original style  
CSAZ-13350-B



65-70: Electronic Variable Flasher, for use with our sequential tail lights  
STL-EVF-13350

### HORN SWITCH

Fits deluxe or standard 2 spoke wheel.



#### Horn Switch

70-73 ..... D2AZ-13875

### RIM BLOW HORN SWITCH

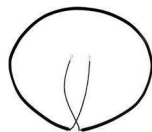

The switch that goes inside the rim of the steering wheel to actuate the horn.

#### Horn Switch, Rim Blow

69 ..... C9AZ-13A875-C  
70-73 ..... D1AZ-13A875-A

### IGNITION SWITCH



Reproduction switches at an affordable price. Switches do not include bezels.

#### Ignition Switch

64-66 ..... C3UZ-11572-A  
67 ..... C5AZ-11572-B  
68-69 ..... C8AZ-11572-A  
71-72 ..... D1AZ-11572-BR

### IGNITION SWITCH PIGTAIL



Correct As Original. Repair harness that requires splicing.

#### Ignition Switch Pigtail

64-66 ..... C3UZ-11572-RPT

### IGNITION SWITCH RETAINER

A "must have" part when installing an ignition switch. Zinc plated for years of service.

#### Ignition Switch Retainer



64-66  
C4DZ-10A885-A



67-68  
C7Z-11A590-B

### NEUTRAL SAFETY SWITCH



These Neutral Safety Switches were unexpectedly made obsolete by Motorcraft and availability was getting scarce, but

they are now made by Scott Drake and available once again! Our Classic Mustang neutral safety switches are high quality reproduction parts made from original Ford prints.

#### Neutral Safety Switch

64-67 C-4, before 12-15-66 ..... C4AZ-7A247-C  
67-69 C-4, C-6, after 12-15-66 .. C9Z-7A247-B

### TURN SIGNAL CANCEL CAM

Great reproduction of an often broken part.

#### Turn Signal Cancel Cam



65-66  
C3DZ-13318-B

### Turn Signal Cancel Cam



67-71: Without tilt  
C7SZ-13318-B



68-69: With tilt  
C8AZ-13318-A



73  
D0AZ-13318-A

### TURN SIGNAL HARNESS SOCKET



This hard to find part is now made by Scott Drake! This makes installing the 68-69 Mustang turn signal switch easier. Made

from translucent ABS plastic using the original Ford print.

#### Turn Signal Harness Socket

68-72 ..... C8AZ-14489-S

### TURN SIGNAL SWITCH



These switches are exact copies of the originals.

#### Turn Signal Switch

64 ..... C3OZ-13341-B  
65-66 ..... C5OZ-13341-BR  
67 With tilt, requires splicing . C7Z-13341-E  
67 Without tilt ..... C7Z-13341-F  
68 Without tilt ..... C8SZ-13341-A  
68-69 With tilt ..... C8SZ-13341-B  
69 Without tilt ..... C9AZ-13341-B  
70-72 Without tilt ..... D2AZ-13341-C  
70-72 With tilt, requires splicing D2AZ-13341-D  
73 With tilt ..... D6AZ-13341-A  
73 Without tilt ..... D6AZ-13341-B

## LIGHT BULBS

### LIGHT BULB

Replacement bulbs from O.E.M. suppliers to the auto industry. Excellent quality bulbs.



#### Light Bulb

64-66 Exterior ..... 1157  
64-69 Exterior ..... 1142

**Light Bulb**

64-70 Interior	1445
64-70 Interior	1895
64-73 Dome	1003
64-73 Interior	1893
64-73 Dashboard	631
64-73 Exterior	97
65-66	1816
65-73 Door, courtesy	1004
67-68 Exterior	53
67-68 Door courtesy	90
67-73 Exterior	1157A
68-73 Interior, exterior	194
70 Ash tray	1892
70-73 Exterior	1156
71 Dome	105
71-73 Dome bulb	561

**PARKING LIGHTS**

**LED PARK AND TURN SIGNAL LIGHT**

LED lights are brighter, more reliable, and run cooler than traditional bulbs.

**Park and Turn Signal Light, LED**



64-66: Panel assembly  
CSZ-13200-LED



64-73: Amber 1157 Bulbs only  
SD-1157-UB

**PARK LIGHT ASSEMBLY**



Complete housing with wiring. Bulb and lens included unless stated otherwise.

**Park Light Assembly**



64-66: Right hand, bulb & lens not included  
CSZ-13206-B



64-66: Left hand, bulb & lens not included  
CSZ-13207-B



67-68: Orange bulb\*  
C8Z-13200-B



69: Right hand  
C9Z-13200-A

**Park Light Assembly**



69: Left hand  
C9Z-13201-A



70: Right hand  
D0ZZ-13200-A



70: Left hand  
D0ZZ-13201-A



71-72: Right hand  
D1ZZ-13200-A

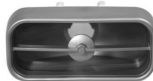

71-72: Mach 1, right or left hand, bulb not included  
D1ZZ-13200-B



71-72: Left hand  
D1ZZ-13201-A

**COMPLETE PARK LIGHT ASSEMBLY**



Complete assembly which includes: main body, electric housing and socket assembly, pigtail, lens, bulb, and gasket.

**Park Light Assembly, Complete**

67-68 Right Hand	C7ZZ-13210/20-K
67-68 Left hand	C7ZZ-13212/21-K

**PARK LIGHT BEZEL**

Very nice reproductions. Ready for paint. Sold in pairs.

**Park Light Bezel**



67-68: Unpainted  
C7Z-13210/12



70: Mach 1, Unpainted  
D0ZZ-13210

**COMPLETE PARK LIGHT KIT**



Kit includes one pair of parking lamp housings, pads, lenses, gaskets, bulbs and mounting hardware. Retainers sold

separately.  
**Park Light Kit, Complete**

64-66	KIT-ELC-1
-------	-----------

**PARK LIGHT LENS**

Made to original specifications.



**Park Light Lens**



64: White, with FoMoCo logo\*  
CSZ-13208-WTR



65-66: Amber, with FoMoCo logo\*  
CSZ-13208-AR



64-66: Amber, without logo  
CSZ-13208-A



67-68: With FoMoCo logo\*  
C7Z-13208-A A



69-70: With Ford logo\*  
D0ZZ-13208/9



71-72: Amber, with Ford logo\*  
D1ZZ-13208/9

**PARK LIGHT LENS GASKET**



Gray foam gaskets to seal lens against housing.

**Park Light Lens Gasket**

64-66	CSZ-13211-A
67-68	C7ZZ-13211-A
69-70	C9ZZ-13211-A
70 Mach 1	C9WY-13211-A
71-72	D1ZZ-13211-A

Electrical

**WE PROUDLY FEATURE AUTHENTIC MUSTANG REPRODUCTIONS FROM SCOTT DRAKE ENTERPRISES!**





### **PARK LIGHT LENS KIT**



This kit includes mounting pads, lenses, gaskets, bulbs and mounting hardware.

**Park Light Lens Kit**  
64-66 .....KIT-ELC-2

### **PARK LIGHT LENS SCREW**

Stainless steel to prevent corrosion.



**Park Light Lens Screw**  
64-68 Set of 4 .....378716-5

### **PARK LIGHT SEAL**

Molded sponge, protects paint from chipping.



**Park Light Seal**  
64-66 .....C5ZZ-13217-A/B

### **PARKING LIGHT RETAINER**

Stamped steel and zinc plated to prevent rust. Fits behind parking lamps.



**Parking Light Retainer**  
64-66 Right hand .....C5ZZ-13220-C  
64-66 Left hand .....C5ZZ-13221-C  
67-68 Right hand .....C7ZZ-13220-A  
67-68 Left hand .....C7ZZ-13221-A

## **SIDE LIGHTS & REFLECTORS**

### **MARKER TO BODY SEAL**

These parts are precision die-cut for a great fit the first time.



**Marker To Body Seal**  
69 Set of 4 .....C9AZ-15A447  
70 Rear .....D0ZZ-15A447  
71-73 Rear .....D1ZZ-15A447

### **QUARTER PANEL REFLECTOR**



This side marker reflector mounts on the rear of the quarter panel.

#### **Quarter Panel Reflector**

 68: Late, with FoMoCo logo\*  
C8GY-13380-A

 68: Late, w/out logo  
C8GY-13380-AR

 68: Early, with FoMoCo logo\*  
C8ZZ-13380-A

### **SIDE MARKER BEZEL**

The bezel that surrounds the marker lens.

#### **Side Marker Bezel**

 68: Early, ready to paint, rear, right hand or left hand  
C8ZZ-13381-A

 69: Chrome, front or rear, right or left  
C9AZ-15A440-A

 70: Chrome, rear, left hand  
D0ZZ-15A440-BL

 70: Chrome, rear, right hand  
D0ZZ-15A440-BR

 70: Chrome, front, left hand  
D0ZZ-15A440-L

 70: Chrome, front, right hand  
D0ZZ-15A440-R

 71-73: Ready to paint, rear, right and left hand  
D1ZZ-15A440-C/D PR

### **SIDE MARKER LENS**



A quality reproduction with correct red, clear, or amber lens.

#### **Side Marker Lens**

 69: Rear, right or left hand\*  
C9AZ-15A201-C

 69: Front, right or left hand\*  
C9DZ-15A215-C

 70: Front, right hand\*  
D0ZZ-15201-A

 70: Front, left hand\*  
D0ZZ-15201-B

 70: Rear, right or left\*  
D0ZZ-15201-R

 71-73: Front, right hand\*  
D1ZZ-15201-A

 71-73: Front, left hand\*  
D1ZZ-15201-B

 71-73: Rear, right hand\*  
D1ZZ-15A201-C

 71-73: Rear, left hand\*  
D1ZZ-15A201-D

### **SIDE MARKER LIGHT**

Complete pair of assemblies. Ready to install. Correct amber bulbs included.



**Side Marker Light**  
68 Right and left .....C8ZZ-15A201-C/D

**SIDE MARKER SOCKET**



Replacement light socket for side markers.

Side Marker Socket  
69-73 ..... D0DZ-15434

**SPORT LAMPS**

**SPORT LAMP LENS**

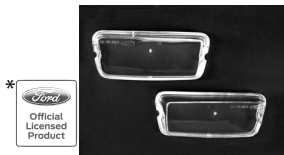

Sport Lamp Lens  
70 Mach 1, with Ford logo\* . C9WY-13208/9

**TAIL LIGHTS & BACK UP LIGHTS**

**LED BACK UP LIGHT**



These LED panels glow white when illuminated. Much brighter and whiter than standard bulbs.

These lights are a

great improvement over stock bulbs and compliment the LED Sequential Tail Light Kits. Available in a kit for 1964-68 Mustangs: Includes two lights and gaskets for both sides of the car, lens, and mounting screws. Also available are replacement bulbs that fit in your standard 1142 light sockets, for 1964-70 Mustangs. Lifetime warranty!

**Back Up Light, LED**

64-70 Panel assemblies .....SD-1142-RFB  
64-70 Bulbs only .....SD-1142-UB

**BACK UP LIGHT HOUSING**



Great chrome, housings include wiring pigtail. Lenses, gaskets, and bulbs sold separately.

**Back Up Light Housing**

64-66 Right hand .....C5ZZ-15511-A  
64-66 Left hand .....C5ZZ-15512-A  
67-68 Right hand .....C7ZZ-15511-BR

**Back Up Light Housing**

67-68 Left hand .....C7ZZ-15512-BR

**BACK UP LAMP, COMPLETE**



**Back Up Lamp, Complete**

69-70 Right hand .....C9ZZ-15511-A  
69-70 Left hand .....C9ZZ-15511-B

**BACK UP LIGHT INSTALLATION KIT**



This kit includes mounting pads, lenses, gaskets, bulbs and mounting hardware.

**Back Up Light Installation Kit**

64-66 .....KIT-ELC-9

**BACK UP LIGHT KIT**



This large kit includes backup housings, pads, lenses, gaskets, bulbs and installation hardware.

**Back Up Light Kit**

64-66 .....KIT-ELC-8  
67-68 .....KIT-ELC-7

**BACK UP LIGHT LENS**

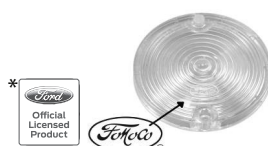

Molded white lenses just like originals. Fits either side.

**Back Up Light Lens**

64-66 Amber - export .....C5ZZ-15514-AMB  
64-68 No logo .....C5ZZ-15514-A  
64-68 With FoMoCo logo\* .....C5ZZ-15514-AR  
69-70 With FoMoCo logo\* .....C9ZZ-15514-B

**BACK UP LIGHT LENS GASKET**



Molded sponge, good fit. Seals lens to housing.

**Back Up Light Lens Gasket**

65-70 .....C5ZZ-15510-A

**BACK UP LIGHT LENS SCREW**



Stainless steel to prevent corrosion.

**Back Up Light Lens Screw**

64-68 Set of 4 .....380438-S

**BACK UP LIGHT PIGTAIL**



The harness that connects to the back up switch on 4 speed cars.

**Back Up Light Pigtail**

70 4 speed .....70-BU-4

**BACK UP LIGHT SWITCH**



Our back-up switch features a weather sealed U.S. made switch with a zinc plated mounting bracket.

**Back Up Light Switch**

64-66 4 speed .....C5ZZ-15520-A  
64-66 3 speed .....C5ZZ-15520-C  
67-68 4 speed .....C7ZZ-15520-A  
67-68 3 speed .....C7ZZ-15520-C

**LICENSE PLATE LIGHT LENS**



A nice reproduction to replace those cracked and yellowed originals.

**License Plate Light Lens**

64-74 .....C4AZ-13564

**SEQUENTIAL CONTROL MODULE**



These control modules feature variable rate adjusters and color coded wire harnesses. Perfect for custom tail lights. Note: requires

STL-EVF-13350 Variable Flasher (found under "Interior Switches", earlier in the Electrical & Lighting category).

**Sequential Control Module**

65-70 .....STL-13A366

**CLASSIC MUSTANG SEQUENTIAL**

**TAIL LIGHT KIT**



These three bulb inserts enhance the brightness of the tail lights by 200 percent. A simple "drop-in" insert. 65-66 also

Electrical

**WE PROUDLY FEATURE AUTHENTIC MUSTANG REPRODUCTIONS FROM SCOTT DRAKE ENTERPRISES!**



57

available with pre-assembled housings.

**Sequential Tail Light Kit, Classic Mustang**

65-66	.....C5ZZ-STL
65-66	Includes housing & high-temp lenses .... C5ZZ-STL-DLX
67-68	.....C7ZZ-STL
69	.....C9ZZ-STL
70	.....D0ZZ-STL

**CLASSIC MUSTANG LED SEQUENTIAL TAIL LIGHT KIT**



Sequential LED tail lights. The ultimate custom look. We combined our new LED tail light panels with our popular

sequential light modules and EVF flasher. Our LED panels were designed with sequential operations in mind. You can choose to have either the large LEDs sequence or the rows of small LEDs. No other product offers you this choice. Electrical connectors and instructions are included for quick and easy installation.

**Sequential Tail Light Kit, Classic Mustang LED**

65-66	Standard LED's.....C5ZZ-LED-STL
67-68	.....C7ZZ-LED-STL

**CLASSIC MUSTANG LED (EASY INSTALL) SEQUENTIAL TAIL LIGHT KIT**

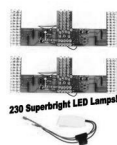

Drake Automotive Group has teamed up with an industry leader in LED Sequential Tail Light systems for the Ford Mustang.

With patented "Smart-signal" technology and exclusive "Batwing" design, these kits offer easy hassle-free installation with no splicing required! These LED's are up to 5 times brighter than stock lights but run cooler and use less energy than traditional bulbs, so they won't melt your lenses. Each kit works with stock lenses and housings, so there is nothing extra to buy. Lifetime warranty! Please note: sequencing speed is not adjustable.

**Sequential Tail Light Kit, Classic Mustang LED (Easy Install)**

64-66	.....SD-0005-UB
67-68	.....SD-6004-UB
67-68	Cal Special/Shelby .....SD-6009-UB
69	.....SD-6003-UB
70	.....SD-6010-UB
71-73	.....SD-6012

**LED STOP AND TURN SIGNAL LIGHT**



The world's brightest LED lights on the market for 1157 light sockets. Auto-parts store LED's don't even compare. Rear LED's

glow red. Lifetime warranty!

**Stop and Turn Signal Light, LED**

64-73	Red 1157 Bulbs .....SD-1157-RFB-RD
-------	------------------------------------

**TAIL LIGHT 3 BULB INSERTS**



These three bulb inserts enhances the brightness of the tail lamps by 200 percent. A simple "drop-in" insert. Can be used

with or without our sequential controllers. C5ZZ-13450-PC lens recommended for 64-66.

**Tail Light 3 Bulb Inserts**

65-66	Twice the brightness ....C5ZZ-STL-13400
67-68	.....C7ZZ-STL-13400
69	.....C9ZZ-STL-13400
70	.....D0ZZ-STL-13400

**LED TAIL LIGHT BULBS**

Same great warranty and features as our superbright LED kits, but equipped with standard LED bulbs to offer you a more affordable kit. Still much much brighter than stock 1157 Bulbs.



**Tail Light Bulbs, LED**

64-66	.....C5ZZ-LED
-------	---------------



**Tail Light Bulbs, LED**

64-66	Super Bright LED Panels .....C5ZZ-LED-SB
-------	--



**Tail Light Bulbs, LED**

67-68	.....C7ZZ-LED
-------	---------------

**64-66 TAIL LIGHT BEZEL**



These are the best the market has to offer. Available in economy or show-quality versions, and available in our new satin finish

for a custom look. Our 64-66 bezels are also available in a kit with the lens (KIT-ELC-3), see "Tail Light Lens & Bezel Kits" later in this

section.

**Tail Light Bezel, 64-66**

64-66	Economy, chrome .....C5ZZ-13489-A
64-66	Show-quality, chrome ...C5ZZ-13489-AR
64-66	Show-quality, satin .....C5ZZ-13489-S

**67-68 TAIL LIGHT BEZEL**

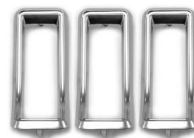

All 67-68 tail light bezels come complete with pads and studs. Available individually or in a kit of 6. Also available in our new

satin chrome finish for a custom look. These are the best on the market. Retaining nuts sold separately, see Tail Light Bezel Retaining Nut later in this section.

**Tail Light Bezel, 67-68**

67	Chrome .....C7ZZ-13489-A
67	Chrome, kit of 6 .....KIT-ELC-5
67	Satin, kit of 6 .....KIT-ELC-5S
68	Chrome .....C8ZZ-13489-A
68	Chrome, kit of 6 .....KIT-ELC-6
68	Satin, kit of 6 .....KIT-ELC-6S

**69 TAIL LIGHT BEZEL**

This tail light trim is made from original Ford tooling for a perfect fit. Also available with our '69 Tail Light Lens (C9ZZ-13450-A), see "Tail Light Lenses" later in this section.

**Tail Light Bezel, 69**



69: Stainless steel  
C9ZZ-13450-S



69: Stamped aluminum  
C9ZZ-13489

**70 TAIL LIGHT BEZEL**



These are beautiful reproductions. Available with a bright chrome finish and black accent lines, or without a chrome

finish for BOSS applications. Available in original Ford tooling or reproduction on chrome versions.

**Tail Light Bezel, 70**

70	Chrome, right hand .....D0ZZ-13489-A
70	Chrome, left hand .....D0ZZ-13489-B
70	Without chrome, right hand ..... D0ZZ-13489-R
70	Without chrome, left hand ..... D0ZZ-13489-L
70	Chrome, right hand, reproduction ..... D0ZZ-13489-AR
70	Chrome, left hand, reproduction ..... D0ZZ-13489-BR

**BILLET TAIL LIGHT BEZEL**

Made from a block of billet aluminum. Our 65-66 versions Feature black button head screws, and are a perfect match to our billet gas caps. 67-68 version features a brushed-aluminum raised trim with contrasting, textured-finish on recessed areas, unique pivoting mounting studs, and includes stainless-steel hardware and body gaskets.

**Tail Light Bezel, Billet**



65-66: With accent lines  
B-13489-A



65-66: Without accent lines  
B-13489-B



67-68  
B-13489-67

**SHELBY TAIL LIGHT BEZEL**

High quality reproductions. Made in the U.S.A.

**Tail Light Bezel, Shelby**

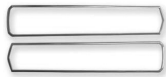

67: Shelby, satin aluminum  
S7MS-13489



68-70: Shelby/68 Cal Special, chrome  
C5SZ-13489-A

**TAIL LIGHT BEZEL SCREW**



Exact copy of the original. Features stainless steel construction.

**Tail Light Bezel Screw**

64-66 Set of 8 .....50398-SK

**TAIL LIGHT HOUSING**

\* Tail Lamp Housing w/ wire pigtail.



**Tail Light Housing**



64: With pigtail  
C4ZZ-13434-A

**Tail Light Housing**



65-66: Original plug in style, includes bulb  
C5ZZ-13434-A



65-66: Concours w/ FoMoCo logo & SAE markings, includes bulb\*  
C5ZZ-13434-B



67: Shelby and Eleanor, ABS plastic housing  
S7MS-13434

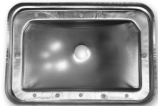

67-68: Right and left hand  
C7ZZ-13434-A

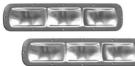

68: Right and left hand  
C8ZX-13434



69  
C9ZZ-13434



70  
D0ZZ-13434



71-73  
D1ZZ-13434

**TAIL LIGHT HOUSING GASKET**

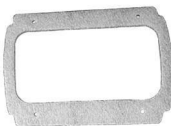

This gasket goes between the tail light housing and the body of the car on 1964 through 1966 Mustangs.

**Tail Light Housing Gasket**

64-66 .....C5ZZ-13420-A

67-68 Bezel to Lens .....C7ZZ-13420-A

69 .....C9ZZ-13420-A

**TAIL LIGHT HOUSING MOUNTING**

**NUT**



These hard to find nuts are concours correct and feature high-quality zinc plating.

**Tail Light Housing Mounting Nut**

64-66 Set of 8 ..... 359606-S8

**Tail Light Housing Mounting Nut**

67-68 Set of 12 .....377523-S

**TAIL LIGHT HOUSING SPACER**

Cadmium plated for corrosion resistance.



**Tail Light Housing Spacer**

64-66 Set of 8 .....C5ZZ-13A547-AK

**TAIL LIGHT HOUSING TO BODY SEAL**



Thick black molded mounting pads which protect and seal trunk from water and dirt.

**Tail Light Housing To Body Seal**

67-68 .....C7ZZ-13520

69 .....C9ZZ-13520

70 .....D0ZZ-13520

71-73 .....D1ZZ-13520

**TAIL LIGHT LENS**

\* Excellent injection molded part, with crisp detail and the correct red color.



**Tail Light Lens**



64-66: Economy, no FoMoCo logo  
C5ZZ-13450-A



64-66: With FoMoCo logo, concours\*  
C5ZZ-13450-AR



64-66: High Temperature, for 3 bulb inserts  
C5ZZ-13450-PC



65-66: Clear, (requires red bulbs)  
C5ZZ-13450-CLR



67: Cougar or Shelby\*  
C7WY-13450



67-68\*  
C7ZZ-13450-A

Electrical

**WE PROUDLY FEATURE AUTHENTIC MUSTANG REPRODUCTIONS FROM SCOTT DRAKE ENTERPRISES!**



59

### Tail Light Lens



68-70: Shelby/68 Cal special\*  
C5Z-13450-C



69: With stainless Trim\*  
C9Z-13450-A



70\*  
D0Z-13450



71-73: With bezel\*  
D1Z-13450

### TAIL LIGHT LENS & BEZEL KIT



This kit includes 2 daily driver style bezels and lenses, gaskets and mounting hardware.

### Tail Light Lens & Bezel Kit

64-66 ..... KIT-ELC-3

### TAIL LIGHT LENS GASKET

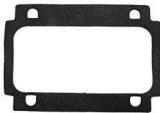

Precision die-cut gaskets for hassle-free installation. Made from the original type of material in each case.

### Tail Light Lens Gasket

64-66 .....C5Z-13461-B  
67-68 .....C7Z-13461-A  
67 Cougar and Shelby ..... C7WY-13461  
68-70 Shelby and Cal Special .....C4SZ-13461-A  
69 .....C9Z-13461-A

### TAIL LIGHT PIGTAIL



These are the correct color code and are just like the originals.

### Tail Light Pigtail

64-66 Left hand .....C40Z-13A408-AL  
64-66 Right hand ..... C40Z-13A408-AR  
67 Shelby ..... S7MS-13A408-A  
68 Shelby ..... S9MS-13A408-A

### TAIL LIGHT RETAINING BOLT



### Tail Light Retaining Bolt

69-73 Does not fit 1970 ..... 382764-S

### TAIL LIGHT WIRING HARNESS



Features the correct color coding for left hand tail lights. Exact copy of original weatherproofing rubber plug and

connecting terminals.

### Tail Light Wiring Harness

64 Coupe & convertible, Without tail light plugs ..... C4Z-14405-CP  
65 Coupe and convertible ... C5Z-14405-CP  
65 Fastback ..... C5Z-14405-FB  
66 Coupe and convertible ... C6Z-14405-CP  
66 Fastback ..... C6Z-14405-FB  
67 Coupe and fastback ... C7Z-14405-65W  
67 Coupe and fastback without low fuel warning light ..... C7Z-14405-65WO  
67 Convertible ..... C7Z-14405-76W  
67 Convertible without low fuel warning light ..... C7Z-14405-76WO  
67 All .....C7Z-14405-ALL  
68 Shelby/California Special ....C8ZX-14405  
68 Coupe and convertible ..... C8Z-14405-CPCV  
68 Fastback .....C8Z-14405-FB  
69 Without safety group .....C9Z-14405-A  
69 With safety group .....C9Z-14405-B  
70 Without light sockets ..... D0Z-14405-A  
70 With light sockets .....D0Z-14405-W5

## UNDER-HOOD ELECTRICAL

### ALTERNATOR HARNESS



Attaches to the back of alternator or generator. Plugs into main headlight harness and grounds to the block. Features correct color

coded terminal covers for water proofing electrical connections.

### Alternator Harness

64 6 Cylinder .....C4Z-14056-6GN  
64 8 Cylinder .....C4Z-14056-8GN  
65 6 cylinder with gauges ..... C5Z-14056-6WG  
65 6 cylinder with warning lights ..... C5Z-14056-6WL

### Alternator Harness

65 8 cylinder with gauges ..... C5Z-14056-8WG  
65 8 cylinder with warning lights ..... C5Z-14056-8WL  
66 6 cylinder ..... C6Z-14056-6  
66 8 cylinder ..... C6Z-14056-8  
67-68 6 cylinder without tachometer ..... C7Z-14056-6WO  
67-68 Big block without tachometer ..... C7Z-14056-BBWO  
67-68 Big block with tachometer ..... C7Z-14056-BBW  
67-68 Small block without tachometer ..... C7Z-14056-SBWO  
67-68 Small block with tachometer ..... C7Z-14056-SBWT  
69 Without tachometer .. C9Z-14056-WOT  
69 With tachometer ..... C9Z-14056-WT  
70 Without tachometer ..D0Z-14056-WOT  
70 With tachometer .....D0Z-14056-WT  
71 With instruments ..... D1Z-14056-WI  
71 Without instruments ..... D1Z-14056-WOI  
72 With instruments ..... D2Z-14056-WI  
72 Without instruments . D2Z-14056-WOI

### ALTERNATOR TERMINAL COVER



Alternator terminal cover (some applications use two, while others three). Packaged as a 3 piece set.

### Alternator Terminal Cover

67-70 .....C7Z-14056-ATC

### AUTOLITE BATTERY



Our Autolite Sta-Ful batteries are authentic reproductions of the originals that use the original case, and not just cover

molds. These batteries are maintenance free, utilizing the latest AGM (Absorbent Glass Mat) technology so they never require adding acid or water filling. The electrolyte is trapped in the separators so the battery can't leak, even if the case is broken. They come fully charged and ready for installation. These are not generic batteries inside a case, they are full true AGM batteries. Long term storage is not recommended. Do not order at the beginning of your restoration. Warranty starts on the "date-of-purchase," not date of installation. Group 27 requires a specific battery tray. Made in the U.S.A.

### Battery, Autolite

64-72 Group 24 ..... C1DZ-10655-A  
64-72 Group 27 ..... C7DZ-10655-B

**BATTERY TRAY MOUNTING KIT**



Includes all hardware necessary to mount battery tray to inner fender apron.

**Battery Tray Mounting Kit**  
64-66 ..... CSZZ-10732-MK

**BATTERY CABLE KIT**



Each of these great kits include all three required cables, including part numbers,

proper terminal and post clamp ends. Starter cables are properly shielded from heat. Most M.C.A. approved. Economy versions do not have part numbers, and terminal clamps are similar to originals.

**Battery Cable Kit**

- 64 Concoars, 8 cylinder \* ..... C4ZZ-14300-8
- 64-66 Concoars, 6 cylinder ..... CSZZ-14300-6
- 64-66 Concoars, 8 cylinder ..... CSZZ-14300-8
- 67 Concoars, 6 cylinder ..... C7ZZ-14300-6
- 67 Concoars, 8 cylinder ..... C7ZZ-14300-8
- 68-69 Concoars, heavy duty, 428CJ ..... C8ZZ-14300-428
- 68-69 Concoars, 6 cylinder ..... C8ZZ-14300-6
- 68-69 Concoars, 8 cylinder ..... C8ZZ-14300-8
- 68-69 Concoars, heavy duty 4 gauge cable \* ..... C8ZZ-14300-HD
- 70-71 Concoars, 6 cylinder ..... D0ZZ-14300-6
- 70-71 Concoars, 8 cylinder ..... D0ZZ-14300-8
- 70-71 Concoars, heavy duty 4 gauge cable \* ..... D0ZZ-14300-HD
- 72-73 Concoars, 6 cylinder ..... D2ZZ-14300-6
- 72-73 Concoars, 8 cylinder ..... D2ZZ-14300-8
- 72-73 Concoars, heavy duty 4 gauge cable \* ..... D2ZZ-14300-HD

**ECONOMY BATTERY CABLE KIT**



Similar quality as our concours cables but without concours correct markings. Cable is correct length. Great option for daily

drivers.

**Battery Cable Kit, Economy**

- 64-66 Economy (no part numbers) ..... CSZZ-14300-E
- 67-70 Economy (no part numbers) ..... C7ZZ-14300-E

**HEAVY DUTY BATTERY CABLE KIT**



These heavy duty battery cables are identical to our economy versions, except they use larger 4g wire to prevent

excessive draw. Makes car starting easier for all cars, and highly recommended for high-compression engines and big block cars. These are similar in appearance to originals, but not concours.

**Battery Cable Kit, Heavy Duty**

- 64-66 4g wires ..... CSZZ-14300-HD
- 67-70 4g wires ..... C7ZZ-14300-HD

**BATTERY CLAMP BOLT KIT**



Carriage bolt and two nuts.

**Battery Clamp Bolt Kit**

- 64-66 ..... CSDZ-10718-MK

**AUTOLITE BATTERY COVER**



Great at shows for an original look. Fits over the top of any group 24 top-post battery with recessed filler caps.

**Battery Cover, Autolite**

- 64-73 Top cover, group 24 ..... C1DZ-10655-BC

**BATTERY COVER TERMINAL EXTENDORS**



Sometimes required when using our Autolite Battery Cover (C1DZ-10655-BC). Extends your battery terminals back to

original height after installing the cover.

**Battery Cover Terminal Extendors**

- 64-73 Use with C1DZ-10655-BC, Autolite Battery Cover ..... C1DZ-10655-TE

**BATTERY FENDER SHIELD**



Rubberized sheet that shields the positive battery post from the inner fender. Kit includes original fasteners.

**Battery Fender Shield**

- 66 ..... C6ZZ-10760-S

**BATTERY HOLD DOWN BOLT KIT**



Kit comes complete with J bolts and mounting nuts.

**Battery Hold Down Bolt Kit**

- 67-70 24F series ..... D0AZ-10756-K
- 67-70 24F series, stainless steel D0AZ-10756-SS

**BATTERY HOLD DOWN CLAMP**

Heavy duty stamped steel construction with black vinyl coating like the original to prevent corrosion.

**Battery Hold Down Clamp**



64-66  
CSDZ-10718-A



67-70: 24F series, billet  
B-10718-BL



67-70: 24F series  
CSAZ-10718-A

**BATTERY HOLD DOWN CLAMP KIT**

Includes battery clamp and bolt (or bolts) required to mount battery on tray.

**Battery Hold Down Clamp Kit**



64-66  
CSDZ-10718-KIT



67-70  
CSAZ-10718-KIT

**BATTERY TRAY**

Exactly like the originals. These battery trays are a popular item for restorers since most of the originals have been destroyed by leaking batteries over the years.

**Battery Tray**



64-66: Black  
CSZZ-10732-C

Electrical

**WE PROUDLY FEATURE AUTHENTIC MUSTANG REPRODUCTIONS FROM SCOTT DRAKE ENTERPRISES!**



### Battery Tray



64-66: use w/"over the top" style clamp kit (part number CSAZ-10718-KIT)  
C5ZZ-10732-D



67-70: Black. Group 24 only.  
C7ZZ-10732-D



71-73: Black  
D1ZZ-10732-B

### DISTRIBUTOR PRIMARY LEAD PIGTAIL



Connects points and condenser, passes through distributor housing and plugs into distributor side of coil.

#### Distributor Primary Lead Pigtail

64-66 High performance .....C5ZZ-12127-HP  
64-68 6 cylinder .....C5ZZ-12127-6PL  
64-68 8 cylinder .....C5ZZ-12127-8PL

### EFI WIRING HARNESS KIT



Our New EFI (Electronic Fuel Injection) Wiring Harness Kit is Plug-And-Play! The wires are top-quality fire

resistant, printed with the name of the sensor or terminal they connect to, equipped with the correct Ford connections and correct length wires, and each kit comes complete with easy to understand instructions. These harnesses fit 302 and 351 Fuel injected HO motors with mass airflow system. Will not fit early speed density cars.

#### EFI Wiring Harness Kit

65-68 .....C5ZZ-14289-EFI

### ENGINE GAUGE FEED HARNESS



Plugs into firewall and connects original style oil pressure sending unit, water temperature sending unit and coil. Also

plugs into heater blower motor on 1964 - 1966 cars.

#### Engine Gauge Feed Harness

64 6 cylinder .....C4ZZ-14289-6  
64 8 cylinder .....C4ZZ-14289-8  
65 6 cylinder with gauges .....  
C5ZZ-14289-6WG

### Engine Gauge Feed Harness

65 6 cylinder with warning lights .....  
C5ZZ-14289-6WL  
65 8 cylinder with gauges & 2 speed heater  
C5ZZ-14289-8WG2  
65 8 cylinder with gauges & 3 speed heater  
C5ZZ-14289-8WG3  
65 8 cylinder with warning lights & 2 speed  
heater .....C5ZZ-14289-8WL2  
65 8 cylinder with warning lights & 3 speed  
heater .....C5ZZ-14289-8WL3  
66 6 cylinder .....C6ZZ-14289-6  
66 8 cylinder .....C6ZZ-14289-8  
67-68 6 cylinder .....C7ZZ-14289-6  
67-68 Big block .....C7ZZ-14289-BB  
67-68 Small block without tachometer .....  
C7ZZ-14289-SBW0  
67-68 Small block with tachometer .....  
C7ZZ-14289-SBWT  
68 Small block with air conditioner .....  
C8ZZ-14289-SBAC  
69-70 351W with air conditioner .....  
C9ZZ-14289351AC  
69-70 6 cylinder .....C9ZZ-14289-6  
69-70 Boss 302 .....C9ZZ-14289-B302  
69-70 Big block .....C9ZZ-14289-BB  
69-70 302, 351W .....C9ZZ-14289-SB  
70 351 Cleveland .....D0ZZ-14289-351C  
71 429 .....D1ZZ-14289-BB  
71-72 302 .....D1ZZ-14289-SB  
71-73 351 Cleveland .....D1ZZ-14289-351  
72 351-4V w/Tach .....D2ZZ-14289-351T

### ENGINE OR TRUNK LIGHT



This handy little lamp can be mounted under the hood or the trunk lid. Features a gravity switch that turns the light on when the lid is

raised and off when lowered.

#### Engine or trunk light

64-73 .....C2RZ-15A700-A

### ENGINE TO FIREWALL GROUND

#### WIRE



Original style heavy gauge black wire with correct terminals.

#### Engine To Firewall Ground Wire

64-68 Concours\* .....FDA-14303-A  
65 .....C5ZZ-14289-GW

### ELECTRIC HORN



#### Horn, Electric

64-73 High pitch, universal .....C5ZZ-13832-A  
64-73 Low pitch, universal .....C5ZZ-13833-A  
65-66 High pitch, concours .....C5ZZ-13832-H  
65-66 Low pitch, concours .....C5ZZ-13833-L  
67-68 High pitch, concours .....C7ZZ-13832-H  
67-68 Low pitch, concours .....C7ZZ-13833-L  
69-70 High Pitch, concours .....B8AZ-13832-B  
69-70 Low Pitch, concours .....B8AZ-13833-B

### OIL PRESSURE EXTENSION LEAD



Oil pressure extension lead with braided yarn covering.

#### Oil Pressure Extension Lead

64-66 With gauges .....C6ZZ-14289-PT

### OIL PRESSURE SENDING UNIT

These senders screw into block and activate warning light when oil pressure is lost or give accurate reading to oil pressure gauge on cars equipped with gauges.

#### Oil Pressure Sending Unit



64-70: 64-65: Warning light 67-70:  
With factory tach  
B6AZ-9278-A



65-73: 65-66: With oil pressure  
gauge 69-73: With oil pressure  
gauge  
C9ZZ-9278-A



67-68: Without factory tach, with  
spade connector  
C7ZZ-9278-A

### HORN RELAY



Mounts on the radiator support for generator equipped cars.

#### Relay, Horn

64 .....C4DZ-13583-A

### REV LIMITER REPAIR PIGTAIL

Easily repairs damaged leads.



Rev Limiter Repair Pigtail  
69-71 .....D0ZZ-12450-RL

### STARTER SOLENOID

This is a good quality starter solenoid at competitive price.



Starter Solenoid  
64-73 Aftermarket .....B6AZ-11450-A  
65 Concours\* .....C5AZ-11450-A  
66 Concours\* .....C6AZ-11450-A  
67-71 Concours\* .....C7AZ-11450-A  
72-73 Concours\* .....D2AF-11450-A

### STARTER SOLENOID CABLE BRACKETS

Kit includes two brackets and grommets for routing battery cable between starter and solenoid on inner fender.



Starter Solenoid Cable Brackets  
64-73 .....C5ZZ-14302-K

### CONCOURS VOLTAGE REGULATOR

We stock these original appearing regulators for all 1964-1973 Mustangs.



Features the proper cover and original logos.

Voltage Regulator, Concours  
64 Generator, with FoMoCo logo\* .....  
C2AF-10505-B  
64 Generator, with Motorcraft logo\* .....  
C3TZ-10505-B  
65 Early 65, with FoMoCo logo\* .....  
C5AF-10316-A  
65-67 Early 67, black and silver with Autolite logo\* .....C5AF-10316-B  
65-67 With air conditioner, black and yellow with Autolite logo\* .....C5TF-10316-A  
68-69 With air conditioner, blue and yellow with Autolite logo\* .....C8TF-10316-A  
68-69 With AC, blue and yellow with Autolite logo - economy reproduction .....  
C8TF-10316-BR  
68-70 Without air conditioner, blue and silver with Autolite logo\* .....C8AF-10316-A

### Voltage Regulator, Concours

70-71 Without air conditioner, blue and silver with Autolite logo\* .....D0AF-10316-A  
72 Without air conditioner, blue and silver with Motorcraft logo\* .....D2AF-10316-A  
72 With air conditioner, blue and yellow with Autolite logo\* .....D2TF-10316-A  
73 Without air conditioner, blue and silver with Autolite logo\* .....D3AF-10316-A  
73 With air conditioner, blue and yellow with Autolite logo\* .....D3TF-10316-A

### VOLTAGE REGULATOR COVER

Generator Regulator Cover.



Voltage Regulator Cover  
64 Black/blue\* .....C2AF-COVER  
64 Black/yellow\* .....C2DF-COVER

### VOLTAGE REGULATOR MOUNTING KIT

3 piece kit. Correct screws to mount voltage regulator.



Voltage Regulator Mounting Kit  
65-67 .....VRM-C5ZL-404  
68 .....VRM-C8ZL-406

### VOLTAGE REGULATOR SCREW CAPS

Plastic caps used to cover sharp points on screws that mount voltage regulator. Sold in pairs.



Voltage Regulator Screw Caps  
64-66 .....C5ZZ-10316-S

### WIRE CLIPS

### UNDERHOOD TURN SIGNAL WIRING CLIPS

These Scott Drake exclusive wire harness clips are great little reproductions with a black or bright chrome finish to catch the eye.

#### Underhood Turn Signal Wiring Clips



67-68: Chrome, set of 5  
377774-C

### Underhood Turn Signal Wiring Clips



67-68: Black, set of 5  
377774-S



67-68: Black, 6 piece, ABS  
377774-SK

### WIRE HARNESS CLIP

Vinyl dipped. Clip is used to hold wiring away from hot engine parts, often attached to LH valve cover bolt. Also found on trunk



floor.  
Wire Harness Clip  
64-73 .....356640-S100

### WIRE LOOM CLIP MASTER KIT

Typical kit does wiring at: battery tray, crossmember, doors, engine feed, fender apron, firewall, gas tank sender, horns,

parking lights, tail lights, and under-dash.  
Note: Includes most common wiring clips, but may not include all clips on the car.

#### Wire Loom Clip Master Kit

65-66 .....C5ZZ-WCK  
67 .....C7ZZ-WCK  
68 .....C8ZZ-WCK  
69 .....C9ZZ-WCK  
70 .....D0ZZ-WCK  
71-73 .....D1ZZ-WCK

### WIRE LOOM MOUNTING KIT

Includes all loom straps, anchors, and clips necessary to correctly install engine bay wiring looms. These are excellent



reproduction that feature excellent fit with concours appearance.

#### Wire Loom Mounting Kit

64-66 .....C5ZZ-14000-BK  
67 .....C7ZZ-14000-BK  
68 .....C8ZZ-14000-BK  
69 .....C9ZZ-14000-BK



**EXTERIOR EMBLEMS**

**BILLET GRILLE EMBLEM MOUNTING CLIPS**

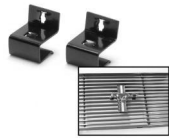

These steel clips are specially designed to mount the C5ZZ-16229-B Running Horse Fender Emblem to a billet grille.

**Billet Grille Emblem Mounting Clips**  
64-11 ..... C5ZZ-16229-BGMC

**EMBLEM KIT**

\*  These kits include every correct emblem for the exterior of your car. Barrel clips are also included. We are the premier manufacturer of emblems, no other maker comes close to our quality, variety or packaging.

**Emblem Kit**



65: GT\*  
C5ZZ-65402828GT



65-66: 6 cylinder, fastback\*  
C5ZZ-6340282-6K



65-66: 8 cylinder, fastback\*  
C5ZZ-6340282-8K



65-66: 6 cylinder, coupe & convertible\*  
C5ZZ-6540282-6K



65-66: 8 cylinder, coupe & convertible\*  
C5ZZ-6540282-8K



66: GT\*  
C6ZZ-65402828GT



67: 6 cylinder\*  
C7ZZ-6540282200



67: 289\*  
C7ZZ-6540282289

**Emblem Kit**



67: 302\*  
C7ZZ-6540282302



67: 390\*  
C7ZZ-6540282390



67: GT, 4 speed\*  
C7ZZ-6540282-GT



67: GT, automatic\*  
C7ZZ-6540282GTA



68: 200, 6 cylinder\*  
C8ZZ-6540282200



68: 289\*  
C8ZZ-6540282289



68: 302\*  
C8ZZ-6540282302



68: 390\*  
C8ZZ-6540282390



68: GT\*  
C8ZZ-6540282-GT



69-72: All\*  
C9ZZ-6540282KIT

**FENDER EMBLEM**



**Fender Emblem**



64-65: 260  
C4DZ-16228-C

**Fender Emblem**



64-66: 289, die-cast zinc, chrome plated  
C30Z-16228-B



64-66: 302 (not a licensed copy of an original Ford emblem)  
C30Z-16228-302

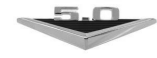

64-66: 5.0 (not a licensed copy of an original Ford emblem)  
C30Z-16228-5.0



64-66: 347  
C30Z-16228-347



64-66: 351  
C30Z-16228-351



65-66: High performance (fits any Scott Drake "V-Badge")  
C5ZZ-16228-B



64-66: High output (fits any Scott Drake "V-Badge")  
C5ZZ-16228-HO



64-73: Powered By Ford, stick-on\*  
S2MS-16228-A

**GT FENDER EMBLEM**

**Fender Emblem, GT**



65: GT Economy  
C5ZZ-16098-D



65: GT, concours, genuine cloisonne  
C5ZZ-16098-DC.



66: GT, porcelain inserts, resembles porcelain style  
C60Z-16098-B

**Fender Emblem, GT**



67: GTA, automatic  
C70Z-16098-A



67: GT, 4 speed  
C7Z-16098-A/B



68: GT  
C7GY-16098-B

**MUSTANG SCRIPT FENDER EMBLEM**



**Fender Emblem, Mustang Script**



64: Mustang, early 4 1/2" version\*  
C5Z-16098-A



65-66: Mustang\*  
C5Z-16098-B



65-66: Mustang 2+2\*  
C5Z-16098-C



68: Mustang script\*  
C8Z-16098-A



69-73: Mustang script, fender and trunk\*  
C9Z-16098-A

**RUNNING HORSE FENDER EMBLEM**



\*Please note: Ford switched to larger pins on back of running horse mid 1968, this included service replacement parts for early cars. Our running horses have correct early version small pins.

**Fender Emblem, Running Horse**



64-68: 64-66: All, right hand 67-68: 6 cylinder, right hand\*  
C5Z-16228-D

**Fender Emblem, Running Horse**



64-68: 64-66: All, left hand 67-68: 6 cylinder, left hand\*  
C5Z-16229-B



64-68: stick-on, sold as a pair LH & RH  
C5Z-16228/9-SK



65-68: 4.6, right hand\*  
C7Z-16228-4.6



65-68: 4.6, Left hand\*  
C7Z-16229-4.6



65-68: 5.0, right hand\*  
C7Z-16228-5.0



65-68: 5.0, Left hand\*  
C7Z-16229-5.0



67-68: 289, Right hand\*\*  
C7Z-16228-C



67-68: 289, Left hand\*\*  
C7Z-16229-C



68: 302, Right hand\*\*  
C8Z-16228-A



68: 302, Left hand\*\*  
C8Z-16229-A



67-68: 351, Right hand\*\*  
C7Z-16228-W



67-68: 351, Left hand\*\*  
C7Z-16229-W

**Fender Emblem, Running Horse**



67-68: 390, Right hand\*\*  
C7Z-16228-D



67-68: 390, Left hand\*\*  
C7Z-16229-D

**SHELBY FENDER EMBLEM**



**Fender Emblm, Shelby**



64-73: Cobra, right hand<sup>§</sup>  
F6ZZ-16228-A



64-73: Cobra, left hand<sup>§</sup>  
F6ZZ-16228-B



67: Shelby GT350<sup>§</sup>  
S7MS-16098-A



67: Shelby GT500<sup>§</sup>  
S7MS-16098-B



68: 428 Cobra Jet\*  
S8MS-16098-G



68: Cobra<sup>§</sup>  
S8MS-16098-S



68-70: Cobra, fender and roof<sup>§</sup>  
C90B-16720-A



69: Flat Cobra snake<sup>§</sup>  
C90B-16228-A



69-70: Shelby<sup>§</sup>  
S9MS-16098-A

**WE PROUDLY FEATURE AUTHENTIC MUSTANG REPRODUCTIONS FROM SCOTT DRAKE ENTERPRISES!**



**Fender Emblm, Shelby**



69-70: 428 Cobra Jet for GT500\*  
S9MS-16C144-A

**GRILLE EMBLEM**



Perfect detail. Mounting hardware included.

**Grille Emblem**



66: Running horse for Shelby, concours\*  
S2MS-8202-K



69: Running horse\*  
C9Z-8213-AR



70: Running horse\*  
D0ZZ-8213-A



71-73: Running horse with tribar, for Mach 1\*  
D1ZZ-8213-B



67: Shelby GT350 grille, dash or deck\*  
S7MS-16098-C



67: Shelby GT500 grille, dash or deck\*  
S7MS-16098-D



69-70: Shelby\*  
S9MS-16098-A

**HOOD LETTERS**



FORD or "SHELBY" hood letters. Only the best. Includes fasteners.

**Hood Letters**



64-66: FORD\*  
C40Z-6240282A/D



67: FORD\*  
C7AZ-16606-A/D E

**Hood Letters**



68-70: SHELBY, chrome, pin version\*  
S8MS-16606-A/E



65-73: SHELBY, chrome, stick-on\*  
S8MS-16606-S



65-73: SHELBY, satin, stick-on\*  
S8MS-16606-SAS

**HOOD SCOOP EMBLEM**



Emblem to go on the sides of the hood scoop. Sold individually.

**Hood Scoop Emblem**



69: 351, black and chrome, diecast  
C9Z-16637-C



69-70: 390, black and chrome, diecast  
C9Z-16637-D



69: 428, black and chrome, diecast  
C9Z-16637-B



69-70: Chrome Cobra Jet script\*  
C9Z-16720-A

**QUARTER PANEL EMBLEM**



Emblems made to factory original specifications.

**Quarter Panel Emblem**



68: California Special\*  
C8ZX-65291A36-A

**ROCKER MOLDING EMBLEM**



Beautiful Reproduction made out of Pressure Die Cast Zinc just like the originals. These can be swedged on like the factory did it or we have included speed clips for a quick and easy install. 2 sets

required per car.  
**Rocker Molding Emblem**



70: Mach 1\*  
D0ZZ-16003-K

**ROOF EMBLEM**



**Roof Emblem**



69-70: Coiled snake, convex for roof\*  
C90B-6542508-A



69-70: Pillar ornament, set of 2\*  
C9ZZ-63517A201A



69-70: Shelby\*  
S9MS-16229-A

**TAIL LIGHT PANEL EMBLEM**

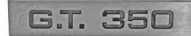

This fine reproduction is die-cast zinc for crisp letters and brushed to duplicate the finish on the original parts. Requires two medium barrel clips (P/N 375890-S).

**Tail Light Panel Emblem**

65-66 GT 350\* ..... S1MS-16098-A

**TRUNK & FENDER EMBLEM**



Die cast zinc painstakingly deburred and chrome plated. Trouble-free mounting. Sold in sets, includes fasteners or 3 M adhesive.

**Trunk & Fender Emblem**



65-72: Mustang, pin version\*  
C5Z-6540282A/G E





65-72: Mustang, Stick on\*  
C5Z-6540282-SK



70: Mach 1 Trunk, chrome, concours\*  
D0ZZ-6340228-KR

**INTERIOR EMBLEMS**

**DASH PANEL EMBLEM**

\*   Excellent reproductions.

**Dash Panel Emblem**



67: Shelby GT350 grille, dash or deck\*  
S7MS-16098-C



67: Shelby GT500 grille, dash or deck\*  
S7MS-16098-D



67-68: Running horse, red & silver, very small 7/8"X3/8", adhesive backed\*  
C7ZZ-65044A90-E



67-68: Running horse tri-bar emblem with base, for Deluxe interior\*  
C7ZZ-65044A90EP



67-68: Running horse tri-bar emblem without base, for Deluxe interior\*  
C7ZZ-65044A90-M EA



67-68: Running horse base only, for Deluxe interior  
C7ZZ-65044A90-P A



68: GT 500\*  
S8MS-6304460-C EA



68: GT 350\*  
S8MS-6304460-D EA



68: Cobra Jet\*  
S8MS-6304460-E EA



69-70: Outer chrome bezel only  
C9Z-6304460 A



69-70: Mach 1, insert only  
C9Z-6304460-AI E

**Dash Panel Emblem**



69-70: Mustang, insert only  
C9Z-6304460-BI



69-70: Grande, insert only  
C9Z-6304460-GI



69-70: Cobra GT 350\*  
S9MS-6304460-A



69-70: Cobra Jet GT 500\*  
S9MS-6304460-B



71-73: Mustang script, except Grande\*  
D1Z-6504774-EM

**DOOR PANEL EMBLEM**



Beautiful detail. Features bright chrome finish and paint. Hardware included.

**Door Panel Emblem**

69-70 69 All, 70 Deluxe: Running horse\* .....  
C9ZB-6520820/3

**SHELBY SEAT BELT INSERT EMBLEM**

\*  They are the most authentic and best looking emblems available.

**Emblem, Shelby Seat Belt Insert**



67: Shelby Cobra\*  
S7MS-63611A73-A



68: Shelby Cobra, gold\*  
S8MS-63611A73-A

**Emblem, Shelby Seat Belt Insert**



69-70: Shelby\*  
S9MS-63611A73-A

**GLOVE BOX EMBLEM**



Pressure die cast, excellent reproductions. Perfect chrome, stripes are painted correct

colors.

**Glove Box Emblem**

64-65 Running horse, curved\* .....  
C4ZB-65060A14-A

65-66 Running horse, flat\* .. C5ZB-65060A14-A

**COBRA INTERIOR EMBLEM**



\*  This small medallion can be used for insertion in shift knobs or other interior applications. 1" diameter.

**Interior Emblem, Cobra**



64-73 \*  
286-101-A

**SILL PLATE EMBLEM**

\*   This is the aluminum emblem which mounts on the center of all scuff plates. Features raised script like original, adhesive backed and protective coating.

**Sill Plate Emblem**



64-66: Black, Ford logo\*  
C5Z-6513208-T



65-66: Shelby\*  
S1MS-6513208-T



67-73: Blue, Ford logo\*  
C7Z-6513208-T



68-73: Blue, Ford logo\*  
C8Z-6513208-T

**WE PROUDLY FEATURE AUTHENTIC MUSTANG REPRODUCTIONS FROM SCOTT DRAKE ENTERPRISES!**



**STEERING WHEEL EMBLEM**



The most authentic and best looking emblems available.

**Steering Wheel Emblem**



67: Running horse\*  
C7ZZ-3649-A



68: Running horse\*  
C8ZZ-3649-AR



68: Shelby Cobra<sup>®</sup>  
S8MS-3649-A



69: For 1969 3-spoke style steering wheel\*  
C9ZZ-3649-B



69-70: Shelby Cobra<sup>®</sup>  
C9MS-3649-A



69-73: For use on 2-spoke wheel  
C9ZZ-3649-S



70-73 \*  
DOZZ-3649

**ENGINE**

**AIR CLEANERS AND COMPONENTS**

**AIR CLEANER**



These are complete air cleaner assemblies. Includes top, bottom and filter element.

**Air Cleaner**



64-65: V8 Chrome/gold, concours, chrome lid and filter, inc. 289 HiPo decal  
C5ZZ-9600-G

**Air Cleaner**



65-67: V8 Chrome/blue, concours, chrome lid and filter, inc. 289 HiPo decal  
C5ZZ-9600



64-71: High performance, economy, chrome top w/ blue bottom, inc. 289 HiPo decal  
C5ZZ-9600-W



64-73: High performance, economy, chrome top w/ blue bottom, inc. 302 HiPo decal  
C8ZZ-9600-W .....



64-73: 6 cylinder, 200-250 w/ Autolite, 1.89" opening, concours, chrome lid and filter  
C4DZ-9600



64-73: 6 cylinder, 1.89" opening  
C4DZ-9600-W

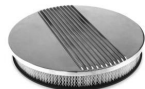

64-73: V8 14" Polished Aluminum Fined  
C5ZZ-9600-AFK



64-73: Oval shape with Mustang logo\*  
C5ZZ-9600-M



64-73: Oval shape with COBRA letters, single carburetor\*  
S1MS-9600-A



64-66: 6 cylinder with open emissions  
C5ZZ-9600-A



65-66: 6 cylinder closed emissions  
C5ZZ-9600-B



67-68: Stock, 260 & 289, closed emissions  
C5ZZ-9600-Y



65-67: Stock, 260 & 289 open emissions  
C5ZZ-9600-Z

**Air Cleaner**



67: 6 cylinder  
C7ZZ-9600-A



64-73: V8, oval, chrome plated  
S1MS-9600-CHR



64-73: oval, without logo, single carburetor  
S1MS-9600-P

**390 GT HIGH PERFORMANCE AIR CLEANER**



Coming soon from Scott Drake, a Concours Reproduction of the extremely rare 67 390 GT High Performance

Air Cleaner under part # C7ZZ-9600-E which includes Blue Base and Chrome Lid. This is also an excellent stock appearing performance upgrade for the very restrictive 68-70 390-428 Air Cleaners. Some early Production 68 390 GT's may have come factory with this Air Cleaner. Chrome Air Cleaner Lid will also be available separately under part # C7ZZ-9661-A. It will fit some other Factory Air Cleaners as well, the Lid's Outside Dimensions are 16.75" so will not fit the more common 17" versions.

**Both Assembly and Lid will be available Summer of 2012.**

- 67 C7ZZ-9600-E w/o CA Emission 390
- 67-68E C7ZZ-9600-C w/CA Emission 390
- 67-68E C7ZZ-9661-A Lid 390, 428, B302

**SHAKER INTERMEDIATE PLATE**



Stamped from Steel like originals. requires drilling 3 holes to attach to air cleaner base and 2 holes for pivot rod. Depending

on engine size minor modification may be required to make work.

**Shaker Intermediate Plate**

- 69-70 Without flapper & vacuum actuator .....
- C9ZZ-9600-IP

**SHAKER INTERMEDIATE PLATE**

**ASSEMBLY**

Stamped from Steel like originals. Depending on engine size minor modification may be required to make work.

**Shaker Intermediate Plate**

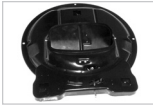

C9ZZ-9D612  
69-70: With flapper & vacuum actuator

**AIR CLEANER BOX**

Air cleaner body and lid only.



**Air Cleaner Box**  
71-73 8 cylinder Ram Air ..... D1ZZ-9600-BOX

**AIR CLEANER DECAL**

Identical to the factory decal that designated engine and carburetor size as well as



service instructions.

<b>Air Cleaner Decal</b>	
64 260 CID*	DF-45
64-65 Service*	DF-83
64-66 Vent	DF-350
64-67 289 High Performance*	DF-15
64-68 Air cleaner, 8 cylinder*	DF-160
64-68 Air cleaner, 6 cylinder*	DF-352
64-73 Front	DF-150
65 170 CID*	DF-95
65-66 289-2V*	DF-13
65-66 289-4V*	DF-14
65-68 200 CID*	DF-59
65-70 Ventra Flow	DF-477
66 200 CID Sprint*	DF-171
66 Part Number	DF-37
66-73 Service*	DF-149
67 Part Number	DF-261
67 Cobra*	DF-744
67-68 289-2V*	DF-104
67-68 289-4V*	DF-105
67-68 Sports Sprint	DF-246
67-68 390 High Performance*	DF-322
67-69 390 CID*	DF-53
67-69 390 4V, premium fuel*	DF-54
68 428-4V, premium fuel*	DF-221
68 427-4V, premium fuel*	DF-316
68 427 4V High Performance*	DF-324
68-69 302 High Performance*	DF-321
68-69 250 CID*	DF-443
68-69 302-2V*	DF-60
68-69 302-4V, premium fuel*	DF-61
69 Boss 302*	DF-162
69 351-2V*	DF-62
69 351-4V, premium fuel*	DF-63
69 428*	DF-778
69-70 Cobra Jet Ram Air*	DF-178
69-70 351 Ram Air*	DF-179

**Air Cleaner Decal**

69-70 428 Cobra Jet*	DF-379
70 250 CID*	DF-172
70-71 302 2V, regular fuel*	DF-182
70-71 302-4V, premium fuel*	DF-183
70-71 351-2V, regular fuel*	DF-184
70-71 351-4V, premium fuel*	DF-185
70-71 390-4V, premium fuel*	DF-479
71 429-4V, regular fuel*	DF-181
71 Boss 351*	DF-260
71 429 Cobra Jet*	DF-395
71 429-4V, premium fuel*	DF-451
71-73 351-2V, regular fuel*	DF-668
72 351 Cobra Jet*	DF-365
72 351 HO*	DF-553
72-73 302-4V, premium fuel*	DF-254
72-73 351-2V, regular fuel*	DF-255
72-73 351-4V, regular fuel*	DF-256
72-73 302-2V, regular fuel*	DF-584
72-73 250 1V*	DF-643

**AIR CLEANER ELEMENT**

Quality air filters designed to meet or exceed the specs of the original factory filter.

**Air Cleaner Element**



64-73: Oval shape, reproduction  
SIMS-9601-



64-74: High performance, concours  
B7SZ-9601-



64-74: Economy  
B7SZ-9601-R

**BILLET AIR CLEANER KNOB**



Here's another nice billet product from Scott Drake. Our air cleaner knob matches our billet radiator cap B-8100 and our billet master cylinder cap B-2162-A. All are beautifully machined and have a soft etched finish. Available with or without the screw hole drilled through. 1/4" x 20 threads.

**Air Cleaner Knob, Billet**

64-73 Solid	B-358871-A
64-73 With hole	B-358871-B

**AIR CLEANER LID GASKET**



New sponge rubber seal which adheres to the inside top of the air cleaner lid.

**Air Cleaner Lid Gasket**

64-73 6 cylinder	C4DZ-9673
65-67 289, 302	C5ZZ-9673
68-73 289, 302, 351 and '67 390	C8ZZ-9673

**AIR CLEANER TO CARBURETOR STUD**

This screw seems to always be missing. We made our screw just a little longer than stock to allow installing the Hi-Po air cleaner. Fit most Autolite 4V carburetors assembly. Zinc plated for years of service. Does not fit Holley or Motorcraft carb.

**Air Cleaner To Carburetor Stud**



64-67: 4V 4 1/2" stud, 1/4" x 20 carb threads  
37005-5



64-68: 2V 4 1/8" stud, 5/16" x 18 carb threads  
370971-5

**AIR CLEANER TO SNORKLE NUT**



Attaches snorkle to air cleaner. Zinc plated.

**Air Cleaner To Snorkle Nut**

64-67	358462-57
-------	-----------

**AIR CLEANER WING NUT**

A nice reproduction.



**Air Cleaner Wing Nut**

64-68 6 cylinder with stud	383132-S
64-73 1/4-20 thread wing nut	358871-S

**HOOD PLENUM**



This is the device that channels the air from the hood scoops to the air cleaner on 1971 through 1973 Mustangs.

**Hood Plenum**

71-73	D1ZZ-16613-A
-------	--------------

**WE PROUDLY FEATURE AUTHENTIC MUSTANG REPRODUCTIONS FROM SCOTT DRAKE ENTERPRISES!**



**SHAKER AIR CLEANER ASSEMBLY**



Fiberglass construction. Features metal air cleaner lid, shaker air cleaner seal and authentic decal. Filter included. See

sheet metal section for hood trim ring. C9ZZ-9600-BB is more than a 1/2" shorter to allow more hood clearance. Neither version includes a flapper plate.

**Shaker Air Cleaner Assembly**

- 69-70 Big block & Boss 302 .....C9ZZ-9600-BB
- 69-70 Small block stock intake .....C9ZZ-9600-S

**SHAKER AIR CLEANER BRACKET**

Exact reproductions that support scoop to air-cleaner base plate.

**Shaker Air Cleaner Bracket**



- 69-70: 428 Cobra Jet  
DOZZ-9A627-C



- 70: Boss 302  
DOZZ-9A627-A



- 70: 351 Cleveland  
DOZZ-9A627-B

**SHAKER AIR CLEANER SEAL**



This rubber seal fits under the shaker intake to help seal around the hood opening.



**Shaker Air Cleaner Seal**

- 69-70 Original Ford\* .....C9ZZ-9B624
- 69-70 Reproduction .....C9ZZ-9B624-C

**SHAKER FLAPPER PIVOT ROD**

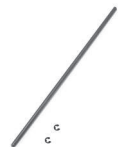

The rod that controls the flapper plate.

**Shaker Flapper Pivot Rod**

- 69-70 With clips .....C9ZZ-9600-PR

**SHAKER FLAPPER PLATE**



Controls air flow to carburetor.

**Shaker Flapper Plate**

- 69-70 Stamped steel .....C9ZZ-9600-FL

**SHAKER SCOOP SPACER PLATE**



This plate attaches Hood Scoop to the Intermediate Plate. Die-cast zinc.

**Shaker Top Scoop**

- 69-70 .....Spacer Plate. C9ZZ-9B634-P

**SHAKER HOOD SCOOP KIT**



All metal construction just like originals. Includes Intermediate Plate, Flapper with Pivot Rod, Vacuum Actuator, Alloy Hood Scoop, Spacer Plate and Rubber Hood Seal. C9ZZ-9600-C Pictured. Look for shaker air cleaner metal base Spring 2012.

- 69-70 With Flapper & vacuum actuator .....C9ZZ-9600-C
- 69-70 Without Flapper & vacuum actuator .....C9ZZ-9600-D

**SHAKER TOP SCOOP**



Die cast alloy like original. Originally used on the Mach 1 and Boss 302.

- 69-70 Alloy .....C9ZF-9B634

**ALTERNATOR COMPONENTS**

**ALTERNATOR BELT**



All belts are constructed by the original manufacturer and made in the U.S.A. Each belt is concours correct with all the authentic inked markings. All belts are approved by Mustang Club of America and

are recognized as concours correct.

**Alternator Belt**

- 65 200 without air conditioner .....C5DE-8620-D
- 65-67 289 High performance .....C5OE-8620-K
- 65-69 260, 289, 302, 66-67 without air conditioner .....C4TE-8620-S
- 66-67 289 with air conditioner ...C4AE-8620-A
- 66-70 200 without air conditioner .....C5DE-8620-C
- 67 390, 428 without air conditioner .....C4AE-8620-D
- 68-69 390 GT, 428CJ without air conditioner ....C6AE-8620-L
- 69-70 428CJ without air conditioner .....C4AE-8620-H
- 70 302 Boss, with power steering .....DOZE-8620-E
- 70 302, Boss 302, 351, 351C without power steering .....DOZE-8620-F
- 70-71 302, 351C with power steering or air conditioner .....C4AE-8620-B

**ALTERNATOR BRACKET**

OEM style brackets. Available in bright chrome or black. Concours versions with correct part numbers stamped into them and will be available late Spring 2012. Ask your dealer for more information.

**Alternator Bracket**



- 65-73: Small block, black  
CSZZ-10145/51BK



- 65-73: Small block, chrome  
CSZZ-10145/51-K



- 69: 351 Windsor, upper head  
bracket  
C9ZZ-10145-A

**CONCOURS ALTERNATOR BRACKETS**

These Alternator Brackets are concours correct. They features all original markings including Ford Part Number, Manufacturer's Logo and FoMoCo stamp where required. These are also the correct thickness per Ford Blueprints and original samples.



Late 65-67	289	C50Z-10156-A
68-69	289-302	C80Z-10156-A



65-67	289	C5AZ-10145-A
68-69	289-302	C70Z-10145-A

### ALTERNATOR FAN



Made from original dies. Plated gold zinc dichromate.

**Alternator Fan**  
65-69 Gold zinc dichromate ... C5AZ-10A310-B

### ALTERNATOR FAN AND PULLEY KIT



Chrome alternator pulley and fan. Includes lockwasher and nut.

**Alternator Fan and Pulley Kit**  
65-73 Chrome, 4 piece kit ... CSZZ-10A310/44C

### ALTERNATOR MOUNTING KIT



Concours correct mounting hardware. Cadmium plated with correct "F" marking. Spacer not included.

**Alternator Mounting Kit**  
65-67 289, 302, 390 and 428 ..CSDZ-10346-MK  
67-70 390 and 428 ..... C7ZZ-10346-MK  
68-69 289 and 302 without smog .....  
C8ZZ-10346-MK

### ALTERNATOR PULLEY

Made by Scott Drake from the original Ford print. Features part number stamped in to the face of the pulley just like the original.

**Alternator Pulley**



65-73: Single  
C5AZ-10344-K



65-73: Dual  
C5AZ-10344-L

### HI PO ALTERNATOR PULLEY



Made by Scott Drake from the original Ford print. Features part number stamped in to the face of the pulley just like the original.

Large diameter pulley was original equipment on 289 HiPo's and Boss 302s. Prevents damage to alternator.

**Alternator Pulley, Hi Po**

64-73 Chrome	.....C5AF-10A352-S
65-73 Black steel	.....C5AF-10A352-C
65-73 Yellow steel	.....C5AF-10A352-H

### ALTERNATOR PULLEY LOCK NUT AND WASHER

Concours correct mounting hardware.



**Alternator Pulley Lock Nut and Washer**

64-73 Gold	.....CSDZ-10346-NG
65-73 Silver	.....CSDZ-10346-NS

### ALTERNATOR SPACER



This spacer is made from extruded aluminum and anodized the correct color.

**Alternator Spacer**

64-69 289 & 302, Gold	..... C5AE-10A370-A
66-70 390 & 428, Pink	..... C5AE-10A370-B
70-73 351C, Silver	.....D00F-10A370-A

## CYLINDER HEAD COMPONENTS

### HEAD GASKET



These are the highest quality U.S. made gaskets. Made by FELPRO.

**Head Gasket**

64-70 6 cylinder	.....C30Z-6051-A
64-73 Small block	.....C3AZ-6051-C/G
67-70 390, 428	..... C7ZZ-6051-D
69 351W	..... C9ZZ-6051-W
70-73 351 Cleveland	..... D0ZZ-6051-C

### HEAD GASKET KIT



This set includes head gaskets, intake manifold, exhaust manifold, carb, base plate, water inlet, valve cover, valve stem seals.

Made by FELPRO.

**Head Gasket Kit**

64-70 6 cylinder	.....C30Z-6051-AK
64-73 Small block	..... C3AZ-6051-C/GK
69 351W	..... C9ZZ-6051-WK
70-73 351 Cleveland	..... D0ZZ-6051-CK

### VALVE STEM SEAL

Made by FELPRO out of long lasting polycrylate for years of service.



**Valve Stem Seal**

64-70 170, 200 intake and exhaust	..... C3DZ-6571-B
64-73 260, 289, 302 exhaust	.....C5ZZ-6571-E
64-73 260, 289, 302 and intake	... C5ZZ-6571-I
67-70 390, 428 intake and exhaust	..... C7ZZ-6571-D
69 351W intake and exhaust	C9ZZ-6571-W
70-73 351 Cleveland exhaust	..... D0ZZ-6571-E
70-73 351 Cleveland intake	..... D0ZZ-6571-I

## DISTRIBUTOR & TIMING

### COIL

Stock to super high power, we have a coil for your needs.

**Coil**



64-73: Yellow top (20,000 volts)  
B6A-12029-B



64-73: Pertronix, Chrome (40,000 volts)  
IGN-40001



64-73: Pertronix, high power, chrome (45,000 volts)  
IGN-40001-2



64-73: Pertronix, black (40,000 volts)  
IGN-40011

**WE PROUDLY FEATURE AUTHENTIC MUSTANG REPRODUCTIONS FROM SCOTT DRAKE ENTERPRISES!**





**Coil**



64-73: Pertronix, high power, black (45,000 volts)  
IGN-40011-2

**COIL BRACKET**



We made our concours bracket capable of holding the smaller coils on the market today as well the original coils. Zinc

plated hex head bolt and nut included. Our bracket is also available in polished stainless steel. Chrome version is a universal bracket that does not resemble original.

**Coil Bracket**

- 64-73 Black ..... C4DZ-12043-A
- 64-73 Stainless .....C4DZ-12043-S
- 64-73 Chrome, universal ..... IGN-10002

**PERTRONIX DISTRIBUTOR**



This stock appearing distributor is the ultimate for the sleeper look. It features a brand new casting along with all

new components including a maintenance free solid state Ignitor, adjustable optimum performance and drivability plus a new High Dielectric strength cap with brass contact cap and a rotor. Very affordable performance distributor without with the aftermarket look which some customers wish to avoid. Fits 260, 289 and 302. Cars with Roller Cam option may need to change out drive gear. Will not fit 351 engines.

**Distributor**

- 64-73 SBV8 .....IGN-D134600

**BILLET DISTRIBUTOR**



Designed to provide maximum ignition performance and easy installation at an affordable price. Now you can upgrade your

outdated points or stock electronic distributor with a performance proven distributor that features the patented Ignitor II module and a CNC machined 6061 T-6 polished billet housing and deck. Comes with a factory configured performance curve with additional spring sets for custom curving.

**Distributor**

- 64-73 With vacuum .....IGN-1307

**Distributor**

- 64-73 No vacuum .....IGN-1308

**FLAME-THROWER DISTRIBUTOR**



Designed for the enthusiast looking for a simple and dependable high energy distributor. Drop in and connect

two wires. it's that simple. features 50,000 volt Flame-Thrower coil that delivers twice the energy across the spark gap compared to a stock HEI distributor. Will not clear some aftermarket intakes.

**Distributor, Flame-Thrower**

- 63-84 Street or strip ..... IGN-D1352
- 63-84 Race only ..... IGN-D1372

**DISTRIBUTOR CAP**



V8 version has Brass contacts-Exact copy of original cap.

**Distributor Cap**

- 55-72 6 cylinder, Motorcraft ..... 7HA-12106-A
- 55-74 V8, Brass .....B7A-12106-A
- 58-74 Autolite logo .....B7A-12106-AR

**DISTRIBUTOR CLAMP**



Features flawless chrome finish and chrome mounting bolt. Will work for most Ford & Lincoln-Mercury applications.

**Distributor Clamp**

- 64-73 Small Block .....C5Z7-12270

**DISTRIBUTOR TUNE UP KIT**



Our tune-up kits have all the required replacement parts. Included in each kit are: rotor, condenser and points.

**Distributor Tune Up Kit**

- 64-73 260, 289, 302, 351, 390 ...COTZ-12000-A

**DISTRIBUTOR VACUUM ADVANCE**

These vacuum advances are made in the U.S.A. by an OEM supplier. Zinc plated to prevent corrosion.

**Distributor Vacuum Advance**



- 64-65: Early 8 cylinder DD-9

**Distributor Vacuum Advance**



- 65-67: 6 cylinder DD-12



- 65-71: 8 cylinder DD-190



- 68-71: Dual vacuum DD-377

**DISTRIBUTOR VACUUM ADVANCE LINES**

Quality one piece lines with correct fittings.



**Distributor Vacuum Advance Lines**

- 64-65 170-6, steel .....MVL003
- 64-65 170-6, stainless ..... MVL003S
- 64-68 Small block, steel .....MVL001
- 64-68 Small block, stainless ..... MVL001S
- 66-68 200-6, steel .....MVL002
- 66-68 200-6, stainless ..... MVL002S

**HARMONIC DAMPER**



High performance or stock specifications, these quality dampers are made in the U.S.A.

**Harmonic Damper**

- 63-67 High Performance "K" ..... C50E-6316-A
- 64-68 5.0 conversion, 3 bolt w/out lip ..... CSAZ-6316-5.0
- 64-68 289, except hi-po .....C5AZ-6316-B
- 65-67 200, 6 cylinder .....C2DZ-6312-A
- 68 302, 3 bolt .....C8AZ-6316-A
- 68-74 Big block 390-428 .....C8AZ-6316-B
- 69 302, 3 bolt with lip .....C90E-6316-D
- 69 351W, 3 bolt .....C90Z-6316-A
- 69 5.0 & 5.8 conversion, 3 bolt, with lip ..... D2TE-6316-5.0
- 69-70 428 SCJ ..... C8AZ-6316-C
- 70-73 302, 4 bolt .....D20Z-6316-A

**PERFORMANCE HARMONIC DAMPER**



Made from extremely tough nodular iron. Suitable for all street applications and mild racing applications. Designed for revving

as high as 6500 rpm. Features gloss black finish with three sets of white timing marks. 80007 used when installing 1981 or newer 302 in a Classic Mustang.

**Harmonic Damper, Performance**

- 64-79 289, 302, 28 oz ..... 80006
- 66-73 390, 428, 50 oz ..... 80009
- 81-93 HP SB Harmonic Damper, 50 oz ... 80007

**HARMONIC DAMPER SPACER**



Correct spacers to fit 80006 & 80007.

**Harmonic Damper Spacer**

- 64-79 351W ..... 81006

**IGNITOR CONVERSION**



Never change points again, plus increase horsepower and improve fuel economy. Fits entirely under the distributor cap,

with no black box to clutter the engine compartment. Installs in minutes, and is completely hidden. Other benefits: Test results show the Ignitor delivers twice the voltage to the spark plugs. No limits to coil and spark energy (spark energy is limited by the coil). A 2:1 improvement over "point type" systems in current fall time. Stable timing with no need for periodic adjustments. Increase spark plug life by 2 to 3 times. No contacts to burn, pit and corrode. No moving and rubbing parts to wear out. Better foul weather performance.

**Ignitor Conversion**

- 64-73 6 cylinder .....IGN-1261
- 64-67 6 cylinder, Pertronix .....IGN-1266
- 64-72 8 cylinder, dual point .....IGN-1281-D
- 64-72 8 cylinder, dual point with vacuum advance .....IGN-1281-DV
- 64-73 8 cylinder .....IGN-1281

**HIGH POWER IGNITOR CONVERSION**



The Ignitor II takes the Ignitor a step further by adding a powerful new microcontroller, that controls the dwell period, for the best

possible spark over the entire RPM range.

Ignitor II offers enhanced performance levels only found in more expensive box type ignition systems. Compared to point type systems Ignitor II develops on average 4 times more available energy between 3,000 and 5,000 RPM, and 2 times more available plug voltage. Higher RPM performance is improved when used with the Flame-Thrower II super low resistance 45,000 volt coil.

**Ignitor Conversion, High Power**

- 64-73 High power 6 cylinder .....IGN-1261-2
- 64-73 High power 8 cylinder .....IGN-1281-2

**SPARK PLUG WIRE SEPERATOR**

Keeps spark plug wires neat and orderly. **Spark Plug Wire Separator**



64-73: Attach to wires  
B6A-12297-A



64-73: Mounts on valve covers  
B8Q-12297-A

**SPARK PLUG WIRE SEPERATOR SET**

These Spark Plug Wire Separators are made of high-quality ABS plastic. Constructed to hold both standard 7mm and 8mm high-performance spark plug wires. Fits directly on valve cover clip. 4 piece sets. **Spark Plug Wire Separator Set**



64-73: Black  
B6AB8Q-12297-KA



64-73: Blue  
B6AB8Q-12297-KB



64-73: Red  
B6AB8Q-12297-KR

**AFTERMARKET SPARK PLUG WIRE SETS**



Our aftermarket wire sets are made from premium radio suppression or wire core cables as per factory specifications.

**Spark Plug Wire Sets, Aftermarket**

- 64-73 Motorcraft, 6 cylinder .C50Z-12259-AMC
- 64-73 Motorcraft, V8 except 390 .....C50Z-12259-BMC

**CONCOURS SPARK PLUG WIRE SETS**



These original type wire sets are made from premium radio suppression core cable. Original appearance and length-matched.

Boots are color correct.

**Spark Plug Wire Sets, Concours**

- 64-66 6 cylinder ..... C50Z-12259-A
- 64-66 8 cylinder ..... C50Z-12259-B
- 65-66 289 High Performance ... C50Z-12259-K
- 66 289 with smog ..... C60Z-12259-A
- 67 6 cylinder ..... C70Z-12259-A
- 67 289 without smog ..... C70Z-12259-B
- 67 390, 428 without smog .. C70Z-12259-C
- 67 289 with smog .....C70Z-12259-F
- 67-68 428 police interceptor, GT500 .....C70Z-12259-D
- 68 289, 302 with smog .....C80Z-12259-E
- 68-69 390, 428 without smog .. C80Z-12259-C
- 68-70 390, 428 with smog ..... C80Z-12259-D
- 68-71 289, 302 without smog .. C80Z-12259-B
- 69-70 Boss 302 .....C90Z-12259-A
- 69-71 351W ..... C90Z-12259-B
- 70-71 351 Cleveland ..... D0ZZ-12259-A
- 71 429, 429C ..... D1ZZ-12259-A

**PERTRONIX SPARK PLUG WIRE SETS**



These low resistance, high performance wire sets feature two current paths. One path is spiral wound stainless steel alloy and

the other is a carbon impregnated fiberglass center core. Other features include low 500 ohm per foot resistance. Silicone jackets used to resist high temperatures, moisture, oil and chemicals. EPDM rubber inner insulation for superior heat resistance and prevention of arching and voltage leaks. Fiberglass reinforcing braid for added strength and flexibility. Available in red, blue and black, these spark plug wires come with a lifetime warranty and are made in the U.S.A.

**Spark Plug Wire Sets, Pertronix**

- 64-73 8mm Black .....IGN-808280
- 64-73 8mm Blue .....IGN-808380
- 64-74 8mm Red .....IGN-808480

**TIMING CHAIN SETS**



Quality timing chain sets in both high performance and stock configurations. Note: C5ZZ-6268-RK will not fit factory 289 HiPo

when using "hatchet" counter balance.

**Timing Chain Sets**

- 64-73 Small block, stock replacement .....C5ZZ-6268-K

**WE PROUDLY FEATURE AUTHENTIC MUSTANG REPRODUCTIONS FROM SCOTT DRAKE ENTERPRISES!**



**Timing Chain Sets**

- 64-73 Small block roller, high performance ..... CSZZ-6268-RK
- 67-70 Roller, big block, high performance ..... CZZZ-6268-RK
- 70-73 351 Cleveland, stock ..... DOZZ-6268-K

**VACUUM LINE HOSE KIT**



All vacuum hoses have correct color striping with repeating "MX" markings. Manufactured by original suppliers.

Markings are very durable and don't come off easily.

**Vacuum Line Hose Kit**

- 68-70 Big block, manual transmission ..... C8ZZ-12226-A
- 68-70 Big block, automatic transmission ..... C8ZZ-12226-B
- 68-73 Small block, dual diaphragm ..... C8ZZ-12226-C
- 68-73 Small block, single diaphragm ..... C8ZZ-12226-D
- 69-70 Boss 302 ..... C9ZZ-12226-A
- 69-70 Boss 429 ..... C9ZZ-12226-B
- 70-73 351 Cleveland with dual diaphragm ..... DOZZ-12226-A
- 71 Boss 351 ..... D1ZZ-12226-A
- 71 429 Cobra Jet, manual transmission ..... D1ZZ-12226-B
- 71 429 Cobra Jet, automatic transmission ... D1ZZ-12226-C
- 71-73 All Ram Air cars ..... D1ZZ-12226-D

**VACUUM MODULATOR LINE**



Runs from intake manifold to modulator on transmission. Includes rubber attaching hose on each end.

**Vacuum Modulator Line**

- 64-65 C-4, V8, steel ..... MVT002
- 64-65 C-4, V8, stainless steel ..... MVT002S
- 64-68 6 cylinder, steel ..... MVT003
- 64-68 6 cylinder, stainless steel ..... MVT003S
- 65-66 C-4, steel ..... MVT001
- 65-66 C-4, stainless steel ..... MVT001S
- 67-69 C-4, V8, steel ..... MVT004
- 67-69 C-4, V8, stainless steel ..... MVT004S
- 68-69 C-6, V8, steel ..... MVT007

**Vacuum Modulator Line**

- 68-69 C-6, V8, stainless steel ..... MVT007S
- 71-73 C-4, V8, steel ..... MVT005
- 71-73 C-4, V8, stainless steel ..... MVT005S
- 71-73 C-6, 351, steel ..... MVT006
- 71-73 C-6, 351, stainless steel ..... MVT006S

**ENGINE BELTS**

**AIR CONDITIONER BELT**



All belts are constructed by the original manufacturer and made in the U.S.A. Each



belt is concours correct with all the authentic inked markings. All belts are approved by Mustang Club of America and are recognized as concours correct.

**Air Conditioner Belt**

- 65-69 Small block 65-67 and 69 before 1-23-69 \* ..... C4ZE-8620-B
- 67-68 Small block after 1-2-67 \* ..C7OE-8620-D
- 70 302, 351W, 351 Cleveland \* ..... DOAE-8620-H

**GENERATOR BELT**



All belts are constructed by the original manufacturer and made in the U.S.A. Each



belt is concourse correct with all the authentic inked markings. All belts are approved by Mustang Club of America and are recognized as concours correct.

**Generator Belt**

- 64 High performance with generator \* ..... C2OE-8620-AC
- 64 Small block with generator \* ..... C4SE-8620-C

**POWER STEERING BELT**



All belts are constructed by the original manufacturer and made in the U.S.A. Each



belt is concours correct with all the authentic inked markings. All belts are approved by Mustang Club of America and are recognized as concours correct.

**Power Steering Belt**

- 64-65 260/289 with generator and Eaton pump \* ..... C3OE-8620-B
- 65 260/289 with air conditioner \* ..... CSAE-8620-E

**Power Steering Belt**

- 65 200 without air conditioner and Ford pump \* ..... C5DE-8620-E
- 65-66 260/289 with Ford pump, without air conditioner \* ..... CSAE-8620-U
- 66 289 with air conditioner \* ..C6OE-8620-D
- 67 390/428 without air conditioner \* ..... CSAE-8620-L
- 67 289 without air conditioner \* ..... C6TA-8620-J
- 67-68 289 with air conditioner \* ..C6OE-8620-A
- 68-69 302/351W without air conditioner and before 10-2-69 \* ..... C6DE-8620-G
- 68-69 390/428CJ/428SCJ without air conditioner and before 10-2-69 \* C8SE-8620-B
- 68-70 390GT/428CJ/428SCJ with air conditioner \* ..... C6AE-8620-T
- 69-70 390/428CJ/428SCJ without air conditioner and after 10-2-69 \* ..C9OE-8620-D
- 70 Boss 302 without air conditioner and 351W with air conditioner \* DOZE-8620-A
- 70 351W without air conditioner \* ..... DOZE-8620-B
- 70-71 351 Cleveland/429 with air conditioner and 302 without air conditioner \* ..... DOAE-8620-K
- 70-71 351C/351 Boss/429 Without air conditioner \* .....D0OE-8620-A

**SMOG PUMP BELT**



All belts are constructed by the original manufacturer and made in the U.S.A. Each



belt is concours correct with all the authentic inked markings. All belts are approved by Mustang Club of America and are recognized as concours correct.

**Smog Pump Belt**

- 68-70 428 Cobra Jet, and Super Cobra Jet without air conditioner \* ... C6OE-8620-B
- 69-70 428 Cobra Jet and Super Cobra Jet with Air conditioner \* .....C8ZE-8620-C
- 70 428 Cobra Jet without air conditioner \* ... DODE-8620-A
- 70 Boss 302 \* ..... DOZZ-8620-A

**ENGINE BLOCK COMPONENTS**

**FULL SET ENGINE GASKET**



Our most complete quality Fel-Pro gaskets set. Includes the following: Head gaskets, exhaust gaskets, exhaust

flanges, valve stem seals, water outlet, carb base plate, oil pan, fuel pump, timing chain cover and water pump gaskets.

**Engine Gasket, Full Set**

- 64-70 6 cylinder .....FS-7916PT2
- 64-73 Small block .....FS-8548PT16
- 67-70 Big block .....FS-8554PT
- 69-70 Boss 302 .....FS-8346PT
- 70-73 351 Cleveland .....FS-8347PT

**ENGINE MASTER FASTENER KIT**



These are really great kits. They include exact original equipment hardware. Again these are not off the shelf generic fasteners, but

have been re-tooled and are made identical to the original. Each kit includes hardware to attach the following: valve covers, air cleaner, intake manifold, oil pan, timing cover, water pump, crank pulley, thermostat housing, heat shield, distributor, carburetor, exhaust manifolds, fuel pump, oil filter adapter, engine tag and ignition coil.

**Engine Master Fastener Kit**

- 64 Small block with generator and air conditioner .....EMK-C20E-336
- 64 Small block High Performance with generator and air conditioner .....EMK-C30E-323
- 64-65 Small block with generator, includes exhaust locks .....EMK-C20E-322
- 65 Small block 289 with aluminum water pump and alternator ....EMK-C50E-559
- 65 Small block 289 with air conditioning ....EMK-C50E-560
- 65 Small block 289 High Performance with aluminum water pump and alternator ..EMK-C50E-561
- 65 Small block 289 with cast iron water pump and alternator ....EMK-C50E-812
- 65 Small block 289 High Performance with cast iron water pump and alternator .....EMK-C5ZE-1067
- 65 Small block GT-350 .....EMK-S1ME-1184
- 66 6 cylinder .....EMK-C6DE-320
- 66 Small block 289 with cast iron water pump and air conditioner and Ramp-locs .....EMK-C60E-337
- 66 Small block GT-350 .....EMK-S2ME-1185
- 66-67 Small block 289 with cast iron water pump and Ramp-locs ...EMK-C60E-324
- 66-67 Small block 289 High Performance with cast iron water pump and Ramp-locs ....EMK-C60E-325
- 67 Big block 390 GT .....EMK-C70E-330
- 67 Small block 289 with air conditioner .....EMK-C70E-562

**Engine Master Fastener Kit**

- 67 Small block GT-350 .....EMK-S7ME-1186
- 67 Big block GT-500 .....EMK-S7ME-331
- 68 Small block 289, 302 .....EMK-C80E-326
- 68 Big block 428 Cobra Jet ..EMK-C80E-333
- 68 Small block 289, 302 with air conditioner .....EMK-C80E-338
- 68 Small block GT-350 .....EMK-S8ME-1187
- 68 Big block GT-500KR and 428 Cobra Jet ...EMK-S8ME-382
- 68 Big block GT-500 .....EMK-S8ME-677
- 68-69 Big block 390 GT .....EMK-C80E-332
- 68-70 6 cylinder .....EMK-C8DE-321
- 69 Small block 302 .....EMK-C90E-1126
- 69 Small block 351 .....EMK-C90E-1128
- 69 Small block 351 with air conditioner .....EMK-C90E-1129
- 69 Small block Boss 302 ....EMK-C9ZE-1180
- 69 Small block 302 .....EMK-D00E-1130
- 69-70 Big block 429 and Boss 429 .....EMK-C9AE-1182
- 69-70 Small block GT-350 without air conditioner .....EMK-C90E-1188
- 69-70 Big block 428 Cobra Jet and Super Cobra Jet .....EMK-C90E-334
- 69-73 6 cylinder 250 .....EMK-C9DE-342
- 69-73 Small block 302 with air conditioner .....EMK-C90E-1127
- 70 Small block 351W .....EMK-D00E-1132
- 70 Small block Boss 302 ....EMK-DOZE-1181
- 70-71 Small block 351 Cleveland with 2 barrel carburetor .....EMK-D00E-1175
- 70-71 Small block 351 Cleveland with 4 barrel carburetor .....EMK-D00E-1176
- 71 Boss 351 .....EMK-D00E-1177
- 72-73 Small block 351 Cleveland with 2 barrel carburetor .....EMK-D20E-1178
- 72-73 Small block 351 Cleveland with 4 barrel carburetor .....EMK-D20E-1179

**ENGINE MOUNT**



Replacement motor mounts. Bonded rubber and steel.

**Engine Mount**

- 64-65 260, 289, Right hand .....C3AZ-6038-G
- 64-65 260, 289, Left hand .....C3AZ-6038-H
- 64-66 6 cylinder right hand .....C4UZ-6038-A
- 64-66 6 cylinder left hand .....C4UZ-6038-B
- 66-72 289, 302, 351W, 69-70 351C, right hand or left hand .....DOZZ-6038-B
- 67-69 200, NOT convertible, right hand or left hand .....C3DZ-6038-E
- 67-70 390, 428 rubber mount ....D1ZZ-6038-A

**HIGH PERFORMANCE ENGINE MOUNT**

**Engine Mount, High Performance**



64-65: Factory 289 Hi-Po C20Z-6039



64-65: Factory 289 Hi-Po C5ZZ-6038-A

**ENGINE MOUNT BLOCK BOLTS**



**Engine Mount Block Bolts**

64-73 V8 .....304668-S

**ENGINE MOUNT BRACKET**

Bolts to frame and motor mount attaches to it. Note: Ford improved their motor mount design in 1966. Our 1966 version is an excellent upgrade for 1964 - 1965 V8 cars and a must for 6 cylinder conversions over to V8 (requires DOZZ-6038-B mounts).

**Engine Mount Bracket**



64-65: 8 cylinder C3DZ-6028/9-C



66-70: 289, 302, 351 C6ZZ-6028/9-A



67-70: 390, 428 C7ZZ-6028-KIT



67-70: 390, 428 engine brackets C7ZZ-6046-PR

**ENGINE MOUNT BRACKET TO BODY BOLTS**



These are the concours correct bolts that attach the engine mount bracket to the base of the shock towers. Serrated flange

nuts included.

**Engine Mount Bracket to Body Bolts**

66-68 .....375117-S

Engine

**WE PROUDLY FEATURE AUTHENTIC MUSTANG REPRODUCTIONS FROM SCOTT DRAKE ENTERPRISES!**



**75**

**ENGINE MOUNT BRACKET TO INSULATOR BOLTS**

These bolts run through both engine mounts and engine mount brackets to secure engine to the car.

**Engine Mount Bracket to Insulator Bolts**



66-69: Concours  
379699-SK



70-73: Concours  
56354-SKt

**TIMING COVER**



A quality after market replacement timing chain cover for cast iron pumps. 289, 302, 351W. Will not fit original style

aluminum water pumps.

**Timing Cover**

64-65 260, 289 For aluminum water pump w/o oil fill tube hode ..... C4AZ-6019-A

65-67 289, 302 For Cast Iron Water Pump Has Molded in Timing pointer, concours ..... C4AZ-6019-B

66-73 289, 302, 351W For cast iron water pump Requires bolt on pointer ... C50Z-6019-B

**TIMING COVER GASKET**

Everything you need, also includes crank shaft seal and sleeve.

**Timing Cover Gasket**



64-73: Small block  
C40Z-6020-A

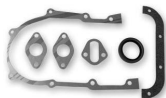

67-73: Big block  
C9ZZ-6020-D



70-73: 351 Cleveland  
D0ZZ-6020-C

**TIMING COVER MOUNTING KIT**



Concours correct fasteners, mounts timing chain cover to engine.

**Timing Cover Mounting Kit**

64 260, 289 with generator ..TCC-C20E-488

**Timing Cover Mounting Kit**

64-65 6 cylinder with generator ..TCC-CODE-499  
64-67 289 with alternator .....TCC-C50E-489  
65-70 6 cylinder with alternator ..TCC-C5DE-500  
68-69 289, 302 and 351 .....TCC-C80E-490

**TIMING POINTER**



Stamped steel pointer mounts to timing chain cover. Black zinc-plated. Includes mounting screw. Fits 289, 302, 351W.

**Timing Pointer**

64-73 .....C20Z-6023-B

**INTAKE MANIFOLD COMPONENTS**

**INTAKE MANIFOLD**



We have taken our highly popular Typhoon™ High Performance street manifold and modified it to produce a

Crosswind variation. The Crosswind design incorporates an open area under the plenum to allow a full flow of cooling air to pass through. This design provides more power and torque due to a colder, more dense intake charge.

**Intake Manifold**

64-85 Polished, Crosswind .... C30Z-9424-CWP  
64-85 Satin, Crosswind ..... C30Z-9424-CWS



Add to your cars performance and beauty with these highly polished or satin finished intake manifolds.

**Intake Manifold**

64-85 Polished ..... C30Z-9424-P  
64-85 Satin ..... C30Z-9424-S

**INTAKE MANIFOLD BOLT KIT**



Concours correct with the exact head markings. Not an off the shelf generic copy. These are 100% correct or your money back!

**Intake Manifold Bolt Kit**

64-67 260, 289 ..... IMB-C40E-478  
67 GT500 ..... IMB-C3AE-493  
67-68 390, 428 ..... IMB-B8AE-475  
68 GT500 ..... IMB-S8ME-477  
68-69 289, 302 ..... IMB-C80E-479  
69 351W ..... IMB-C90E-1131

**Intake Manifold Bolt Kit**

69 Boss 302 .....IMB-C9ZE-1306  
69-70 Boss 429 ..... IMB-C9AE-1376  
69-70 390, 428 ..... IMB-C90E-476  
70 Boss 302 ..... IMB-DOZE-1320  
70-73 351 2V ..... IMB-D00E-1313  
70-73 302 ..... IMB-D00E-1123  
70-73 351 Cleveland 4V ..... IMB-D00E-1321

**INTAKE MANIFOLD GASKET**



**Intake Manifold Gasket**

64-73 Small block .....C3AZ-9441-A  
67-70 Big block ..... C7ZZ-9441-D  
69 351W ..... C9ZZ-9441-W  
70-73 351 Cleveland with 4 barrel ..... D0ZZ-9441-C4

**INTAKE MANIFOLD WASHER KIT**



Very special aluminum washers which are rubber coated. These are the correct ones. Helps eliminate oil leaks. 12 piece kit.

**Intake Manifold Washer Kit**

64-67 ..... IMW-C40E-702

**OIL RELATED PARTS**

**OIL CAP**

\* These factory caps offer you very similar features as the old originals, plus quality you would expect from

**Motorcraft Oil Cap**



64-66: Black, no tube, open, push-on  
CSZZ-6766-FR



64-66: Black, closed with elbow, push-on  
CSZZ-6766-HR



64-66: Chrome, closed with elbow, push-on  
CSZZ-6766-IR



64-68: FoMoCo logo, closed, push-on  
B6AZ-6766-B

**Oil Cap**



64-68: Motorcraft, chrome, twist-on, service replacement, not concours\*  
C3AZ-6766-E



65-66: FoMoCo logo, chrome, with tube, push-on\*  
CSZZ-6766-D



65-67: FoMoCo logo, chrome, twist-on, no emissions control, concours correct for 1967 390 but will fit 68-73 SB and BB Valve Covers as well.  
CSME-6766-A



65-67: FoMoCo logo, Shelby, chrome, push-on\*  
CSZZ-6766-E



65-68: Billet, Push-on  
B-6766-A



65-70: FoMoCo logo, black, with tube, push-on\*  
CSZZ-6766-B



65-70: Chrome and decal, push-on\*  
CSZZ-6766-F



67-70: Autolite Logo, black, closed, twist-on  
C8AZ-6766-A



67-70: Autolite Logo, chrome, closed, twist-on  
C8AZ-6766-B



68-70: No logo, Chrome, closed, twist-on  
C8AZ-6766-BR



68-73: with PCV Black  
D1AZ-6766-A



68-73: with PCV Chrome  
D1AZ-6766-C

**AFTERMARKET OIL CAP**

Brightens the engine compartment and looks sharp. Fits our aftermarket valve covers only.  
**Oil Cap, Aftermarket**



64-73: Chrome, push on, no tube  
W84881B



64-73: Chrome with "OIL" letters, push on  
W89181B



64-73: Chrome, push on, with tube  
W89252B

**OIL CAP PCV ELBOW**



Precision machined to the factory specifications. Light gold anodized finish just like the original. Perfect for our C8AZ-

6766-A or -B oil caps.

**Oil Cap PCV Elbow**

67-70 ..... C8AZ-6767-A

**OIL CAP ADAPTER**



This adapter allows slip-on type oil caps to be used on valve covers with twist-on type oil cap hole.

**Oil Cap Adapter**

64-73 ..... C5AZ-6A868-A

**OIL CAP TO AIR CLEANER HOSE**

Correct hose to connect the oil cap breather to the air cleaner. Features oval FoMoCo logo.

Cut to fit. Requires 2 C3AZ-18572-A Hose Clamps.

**Oil Cap To Air Cleaner Hose**

65-66 Cut to fit\* ..... C4AE-6853-B

**ENGINE OIL DIP STICK**



Our dip sticks are exact reproductions. Don't confuse these with generic imported versions that are kind of close. Stainless steel

versions are polished.

**Oil Dip Stick, Engine**

64 Small block, with generator, light grey ...  
C30Z-6750-B

**Oil Dip Stick, Engine**

64 Small block, with generator, chrome .....  
C30Z-6750-C

65-67 Blue, OE style, 289 ..... C5AZ-6750-B

65-67 Stainless steel handle, OE style, 289 .....  
C5AZ-6750-BC

65-73 Billet w/ Stick ..... B-6750

68-73 Blue, OE style, 289/302 ..... C5AZ-6750-A

68-73 Stainless steel handle, OE style, 289/302  
C5AZ-6750-AC

**ENGINE OIL DIP STICK TUBE**



Original design from Ford Blue Prints available painted or chrome. Perfect fit.

**Oil Dip Stick Tube, Engine**

64 260, black ..... C20Z-6754-A

64 260, chrome ..... C20Z-6754-C

65 289, black ..... C5AZ-6754-A

65 289, chrome ..... C5AZ-6754-C

66-67 289, blue ..... C6AZ-6754-A

66-67 289 chrome ..... C6AZ-6754-C

67-70 390, 428 blue ..... C70Z-6754-A

67-70 390, 428 chrome ..... C70Z-6754-C

68-69 Blue, 68: 289, 302; 69: 302 .....  
C8AZ-6754-A

68-69 Chrome, 68: 289, 302; 69: 302 .....  
C8AZ-6754-C

69 351W blue ..... C90Z-6754-A

69 351W chrome ..... C90Z-6754-C

**ENGINE OIL DIP STICK WITH TUBE**



Resembles the original. All chrome plated. Note: Due to different water pump designs, mounting bracket may need to be modified.

Not concours.

**Oil Dip Stick With Tube, Engine**

64-73 Chrome ..... C5ZZ-6750-K

69-73 351W chrome ..... C9ZZ-6750-K

70-73 351 Cleveland chrome ..... D0ZZ-6750-K

**OIL DRAIN PLUG**

Correct oil drain plug with nylon gasket. Either plain or magnetic.

**Oil Drain Plug**



64-73: Stock with gasket  
D1AZ-6730-A

**WE PROUDLY FEATURE AUTHENTIC MUSTANG REPRODUCTIONS FROM SCOTT DRAKE ENTERPRISES!**



**Oil Drain Plug**



64-73: Magnetic  
C5Z-6730-M

**OIL FILTER**

\* We have concours oil filters available. A must for any show. All are silk-screened with multiple colors.

**Oil Filter**



64-70: Gold, 6000 mile\*  
C1AZ-6731-6000



64-73: White/Red Autolite\*  
C1AZ-6731-FL1F



64-73: Red Rotunda\*  
C1AZ-6731-RIA



64-88: Motorcraft\*  
FL-1A



64-88: Motorcraft, high performance\*  
FL-1HP

**CHROME OIL FILTER COVER**



Quality chrome finish. Slips on your standard oil filter. Secures by tightening allen bolt. Fits all standard oil filters.

**Oil Filter Cover, Chrome**

64-73 .....C5Z-6731-C

**OIL PAN**

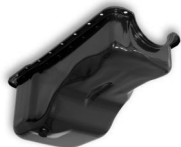

**Oil Pan**

64-70 6 cylinder, black .....C4DZ-6675-B  
64-73 Small block V8, black ..... C5Z-6675-A  
64-73 Small block, blue .....C5Z-6675-B  
64-73 Small block, chrome .....C5Z-6675-C  
64-73 Small block, unpainted ..... C5Z-6675-R

**Oil Pan**

67-70 Concours: 390GT-428CJ, blue w/ part #, baffle, and FoMoCo stamp C60Z-6675-A  
67-70 Big block, blue (except C) . C7Z-6675-B  
67-70 Big block (except Cobra Jet), chrome ..... C7Z-6675-C  
69-73 351W, blue ..... C9Z-6675-B  
69-73 351W, chrome .....C9Z-6675-C  
70-73 351 Cleveland, chrome ..... D0ZZ-6675-C  
71 429, chrome ..... D1ZZ-6675-C

**CAL CUSTOM OIL PAN**



Scott Drake is proud to reintroduce the famous Cal Custom aluminum finned oil pan that was so popular throughout

the 60's, 70's and 80's. It has not been available for years, but it is back again and now even better than before! Not only do these pans look great fully polished with raised fins but they also offer the added benefit of reducing oil temperature to help your engine run cooler. We have even added a strong magnetic drain plug to help protect your engine from destructive metallic particles floating in your oil. These Oil Pans fit: 260, 289, and 302. Also available: Cal Custom Aluminum Finned Valve Covers (C5ZZ-6A582-AF), and Air Cleaner (C5ZZ-9600-AFK).

**Oil Pan, Cal Custom**

64-73 260, 289, 302 ..... C5Z-6675-ALUM

**T OIL PAN**



High capacity aluminum oil pan for 351W Mustangs. Includes pick up tube.

**Oil Pan, T**

69-70 351W .....C9Z-6675-ALUM

**OIL PAN BOLT KIT**



Yes, judges do look under your car! Don't get points taken off because of the wrong bolt. These are concours correct.

**Oil Pan Bolt Kit**

64-73 Small block and 6 cylinder ..... OPB-CODE-484  
67-70 Big block .....OPB-B8AE-340  
69-71 429 ..... OPB-C8SE-486  
70-73 351 Cleveland ..... OPB-D00E-485

**OIL PAN GASKET KIT**

Quality gasket set made by FELPRO.



**Oil Pan Gasket Kit**

64-73 6 cylinder ..... C3DZ-6781-AK  
64-73 Small block ..... C5Z-6781-K  
67-70 Big block ..... C7Z-6781-D  
69 351W ..... C9Z-6781-W  
70-73 351 Cleveland ..... D0ZZ-6781-C

**OIL PAN, BAFFLE, & TUBE KIT**



For Mustang 260/289/302 engines, this kit, from Scott Drake, includes our popular small block oil pan (unpainted)

with the same design of baffle used in the Boss 302, and Boss 302 style oil pickup tube. Reduces the possibility of oil starvation during extreme driving, this kit comes ready to install and paint. Baffle and oil pickup are exact reproductions. Note: C5ZZ-6675 oil pan holds almost 6 quarts of oil.

**Oil Pan, Baffle, & Tube Kit**

65-73 Oil Pan, Baffle, and Tube - fits 260/289/302 ..... C5Z-6675/22-K  
65-73 Baffle & Tube only ..... C5Z-6675/22-B  
69-70 Tube only (fits original Boss 302 oil pans only)..... C9Z-6622-B

**OIL PRESSURE SENDER ADAPTER**



Machined brass adapter threads on to C9ZZ-9278-A sender. This allows the use of C9ZZ-9278-A oil pressure sender on

1967-1968 vehicles. Correct style 67-68 sender is no longer available.

**Oil Pressure Sender Adapter**

67-68 ..... C7Z-9278-ADAPT

**OIL PRESSURE SENDER EXTENSION**

A Beautiful reproduction by Scott Drake. Hex shaped extension. Made from machined metal and chrome or zinc plated.

**Oil Pressure Sender Extension**



64-73: 289-302, zinc  
C20Z-9B339-A



64-73: 289-302, chrome  
C20Z-9B339-C

## OIL PRESSURE SENDING UNIT



These senders screw into block and activate warning light when oil pressure is lost or give accurate reading to oil pressure gauge on cars

equipped with gauges.

### Oil Pressure Sending Unit

64-70 64-65: Warning light 67-70: With factory tach ..... B6AZ-9278-A  
65-73 65-66: With oil pressure gauge 69-73: With oil pressure gauge .... C9ZZ-9278-A  
67-68 Without factory tach, with spade connector ..... C7ZZ-9278-A

## OIL PUMP



These name brand oil pumps are made in the U.S.A. to insure performance and reliability.

### Oil Pump

64-73 260, 289, 302 ..... C5ZZ-6600-A  
70-73 351 Cleveland ..... D0ZZ-6600-A

## SMOG COMPONENTS

### EXHAUST AIR CHECK VALVE



Smog emissions check valve. Fits 6 cylinder and 8 cylinder. Good replacement part not an exact copy. Limited supply!

### Exhaust Air Check Valve

66-71 ..... C60Z-9A487-A

### SMOG DIVERTER VALVE



These are made by Carter, the original supplier to Ford. Not a reproduction but New Old Stock. No Ford part number stamped on

case.

### Smog Divertor Valve

70-72 Boss 302 and Boss 429 ..C8TZ-9B289-AR

### SMOG FERRULE AND NUT



This is the nut and ferrule (one piece) that attaches the smog tube to the cylinder head on 66/67 Mustangs.

### Smog Ferrule and Nut

66-67 ..... C6AZ-9B471-A

## SMOG PUMP FILTER



Brought to you by Scott Drake. New open cell foam.

### Smog Pump Filter

66-67 ..... C6AZ-9A496-A

## UNDER-HOOD COSMETICS

### ECONOMY ENGINE DRESS UP KIT



This is an economical way to dress up your Mustang small block engine or any small block Ford. Brightens engine compartment

for a cleaner look. These kits are pre-packaged, sorry no substitutions. Includes one C5ZZ-9600-W air cleaner with 289 HiPo decal, one pair W89248B valve covers, one W84881B oil cap, one W84889B oil cap grommet and one W89771B PCV grommet. Fits 260-289-302.

### Engine Dress Up Kit, Economy

64-73 ..... C5ZZ-6980

### SHOW-QUALITY ENGINE DRESS UP KIT



Correct, original-style air cleaner with concurs correct valve covers. Includes concurs chrome oil cap. PCV grommet not

included, order part# 382156-S or C8AZ-6892.

Fits 260-289-302

### Engine Dress Up Kit, Show-Quality

64-73 ..... C5ZZ-6980-PRO

### HOOD PROP ROD



This prop rod is made from high quality 304 stainless steel rod and polished to really catch the eye.

### Hood Prop Rod

64-68 Stainless ..... C5ZZ-16826-S

65 Shelby ..... S1MS-16826

### OIL STICK HANDLE



Add some style to your engine compartment with the Scott Drake oil stick handle. This handle is machined from 6061-T6 billet aluminum. We protect it with a satin anodized finish. A perfect match to our engine caps &

covers.

### Oil Stick Handle

65-73 Billet w/ Stick ..... B-6750

### HANDLE TRANSMISSION DIP STICK



Attractive "V" handle made of billet aluminum to replace the stock handle.

### Transmission Dip Stick, Handle

65-73 Billet w/ Stick ..... B-7A020

### UNDER-HOOD CAP

Machined 6061 Billet Aluminum. These caps will add style to your engine compartment.

#### Under-Hood Cap



64-73: Billet  
B-8100



65-66: Billet w/out Stick  
B-3A006-A



65-66: Billet w/ stick  
B-3A006-B



65-68: Billet, Push-on  
B-6766-A



67-70: Billet w/ Stick  
B-3A006-C

### UNDER-HOOD STAINLESS TRIM



This kit will really dress up your engine compartment. High quality polished stainless steel panels and all attaching

hardware included. Complete with installation instructions.

#### Under-Hood Stainless Trim

64-66 ..... ACC-UHT-65

67-68 ..... ACC-UHT-67

69-70 ..... ACC-UHT-69

**WE PROUDLY FEATURE AUTHENTIC MUSTANG REPRODUCTIONS FROM SCOTT DRAKE ENTERPRISES!**





## VALVE COVERS AND COMPONENTS

### PCV FITTING

Exact detail. Gold dichromate finish.



#### PCV Fitting

67-70 Big block ..... C70Z-6A706-A

### PCV HOSE

Concours correct with ink stamped FoMoCo script. Connects PCV valve to



carburetor spacer plate. Requires 2 C3AZ-18572-A Hose Clamps.

#### PCV Hose

65-68 Small block \* ..... C6AZ-6A664-N  
 68-70 Big block \* ..... C8AZ-6A664-D  
 69-70 351W\* ..... C90Z-6A664-A  
 70-73 351 Cleveland\* ..... D0AZ-6A664-C

### AFTERMARKET VALVE COVER

Quality valve covers available at a great price.



#### Valve Cover, Aftermarket

64-66 Economy chrome, fits 260-289-302-351  
 CSZZ-6A582-C  
 64-73 Economy chrome, fits 6-cylinder 170-200-250 ..... C4DZ-6A582-C  
 67-70 Economy chrome, fits 390-427-428 ..... C7ZZ-6A582-C  
 70-73 Economy chrome, fits 351C ..... D0ZZ-6A582-C

### CLASSIC ALUMINUM VALVE COVER



Made by Scott Drake, Classic Aluminum Valve Covers for small block Ford engines! These valve covers are die-cast from high-quality 383-3

aluminum alloy, and then given a durable powder-coated wrinkled finish or polished aluminum finish. They also feature a cadmium plated oil filler tube to help stop corrosion, an improved oil baffle design to accommodate high-lift cam shafts, and will work with most roller rockers. Spark plug wire brackets and PCV grommet included. Available in a variety of styles. Will not fit EFI cars.

#### Valve Cover, Classic Aluminum



64-73: Street Rod, black\*  
 6A582-SR



64-73: Street Rod, polished\*  
 6A582-SRP



64-73: Mustang, block letters, black  
 CSZZ-6A582-A/B (will not clear rollover rockers)



64-85: 289, Black\*  
 6A582-289



64-85: 289, Polished\*  
 6A582-289P



64-85: 302, Black\*  
 6A582-302



64-85: 302, Polished\*  
 6A582-302P



64-85: 351, Black\*  
 6A582-351



64-85: 351, Polished\*  
 6A582-351P



64-85: Shelby, black\*  
 6A582-S

#### Valve Cover, Classic Aluminum



64-85: Shelby, polished\*  
 6A582-SP



64-85: Cobra polished fins, open letter.\*  
 S1MS-6A582-P (will not clear rollover rockers)



65-73: Cobra, solid letters, black  
 S2MS-6A582-A/B (will not clear rollover rockers)



64-73: Cal Custom Polished Aluminum-finned, small block. Will not clear roller rocker.  
 CSZZ-6A582-AF

### ORIGINAL STYLE VALVE COVER



Quality valve covers with a variety of finishes and styles.

#### Valve Cover, Original Style



65-68: Ford blue, fits 260-289-302-352



CSZZ-6A582-BL



64-67: Chrome concours, fits 260-289-302-351  
 CSZZ-6A582-C/D



64-65: Ford gold, fits 260-289  
 CSZZ-6A582-G



68-70: Power By Ford, Ford blue, fits 260-289-302-351\*  
 C80Z-6A582-BL



68-70: Power By Ford, chrome, fits 260-289-302-351\*  
 C80Z-6A582-C



67-70: Power by Ford, chrome, concours, fits 390-428\*  
 C60Z-6A582-C



## VALVE COVER GASKET

Valve cover gaskets, made by Fel-Pro.

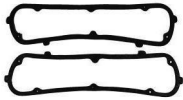

### Valve Cover Gasket

- 62-77 Small block, cork ..... C20Z-6584-AC
- 64-73 6 cylinder ..... CODE-6584-BR
- 64-73 Small block, rubber ..... C20Z-6584-AR
- 67-70 Big block, cork ..... C7ZZ-6584-DC
- 67-70 Big block, rubber ..... C7ZZ-6584-DR
- 70-73 351 Cleveland, cork ..... D0ZZ-6584-CC
- 70-73 351 Cleveland, rubber .... D0ZZ-6584-CR

## VALVE COVER GROMMET

### Valve Cover Grommet



64-68: For original style, stamped-steel valve covers 5/8" ID 1" OD  
C8AZ-6892



64-68: For original style, stamped-steel valve covers 3/4" ID 1" OD  
382156-S



64-73: Pair, Ford motorsport.  
CSZZ-6A892-FMS



64-73: Oil cap, 1 inch inside diameter, works on our chrome aftermarket valve covers  
W84889B



64-73: Oil cap, 3/4" inside diameter, works on our chrome aftermarket valve covers  
W89771B



65-67: 1 inch opening, Aluminum valve covers  
CSZZ-6A892-A



65-73: Round with notches  
C7AZ-6892



67-69: Original factory specs, perfect fit for C80Z-6A582-C  
C6AZ-6892-A

### Valve Cover Grommet



70-71: For original style, stamped steel valve covers  
D00Z-6892

# EXHAUST SYSTEM

## EXHAUST HEADERS

### HI-PERFORMANCE 6 CYL. EXHAUST HEADERS

We believe that a properly modified 6 cyl. will put out as much usable low RPM horsepower as a V8. We offer both the single and dual outlet versions. Single outlet is recommended if no other modifications will be made. Dual outlets work best with Hi-Po Camshaft, 2V carb and Pertronix Ignitor. Single outlet also works well with these modifications. Dual outlet is for customers that want the look and sound of a V8. We recommend buying an exhaust port divider (part # C30Z-9430-EPD) which smooths out air flow between the #3 and #4 cylinder. Will fit Mustangs, Falcons, Rancheros, Comets, Fairlanes, Torinos, and Mavericks.

**Exhaust Headers, Hi-Performance 6 Cyl.**



64-69: Dual outlet, nickel plated, fits 170, 200  
C30Z-9430-H2



64-73: Single outlet, nickel plated, fits 170, 200, 250  
C30Z-9430-H1

### JBA BIG BLOCK, TRI-Y EXHAUST HEADERS



JBA's Tri-Y long tube headers for 390/428 give you the power you're looking for in a package that fits like no other. JBA's designs are application specific to best fit the engine/transmission combination in your Mustang. They also feature big 1-3/4" primaries that flow in to 2-1/4" secondary tubes and terminate in a big 3" collector. Plus they are designed to give maximum ground clearance for street or track use. With heavy-duty stainless steel tubing, thick 3/8" laser-cut flanges and JBA sealing dome collector, you don't have to worry about leaks caused by lesser materials.

\*Note for JBA-6656-S: 69-70 cars with factory

reinforced shock tower may have minor clearance issues. If you are running standard 390 heads versus 390GT heads we can special order you correct headers for the same price. **Exhaust Headers, JBA Big Block, Tri-Y**

67-70 Tri-Y, 390-GT, will not fit standard heads .

JBA-6656-S

69-70 Tri-Y, 428CJ, will clear reinforced towers .

JBA-6655-S1

### JBA SHORTY EXHAUST HEADERS



Custom built premium quality headers. Compare these features to the competition.

Precision laser cut

3/8 inch flanges, Mandrel bent 14 gauge tubes, Patented fire cone which optimizes scavenging, lifetime warranty by maker, sealing dome technology, industrial nickel plating, installation instructions, gaskets and mounting hardware. We feel these are the best headers on the market. Note: 64-65 Mustangs will require 1966-1970 motor mounts and brackets for proper clearance (see "Engine" category).

**Exhaust Headers, JBA Shorty**

64-70 Shorty, 289 and 302 ..... JBA-1650

64-73 Shorty, 289 and 302, ceramic coated .....

JBA-1650-C

64-73 Shorty, 351W ..... JBA-1653-1

### MODIFIED TRI-Y EXHAUST HEADERS



Tubes are CNC mandrel bent, then carefully installed in our precision engineered welding jig for a perfect fit,

& precision welded. They have been fitted on multiple applications and we find them superior to previous suppliers. These fit both automatic & manual, also fit large & small bell housing, along with extra clearance for starter, mounting flange bolts can easily be accessed and they clear Shock Towers.\* Provides full articulation of steering assembly w/out interference. Note: Power Steering cars require Drop Down Bracket. Over forty years of Mustang modifications have resulted in endless configurations and combinations, but we believe this product offers the best overall fit so far. Feature extra thick 3/8" flanges to prevent warping. Metal composite flange gaskets, 1" Primaries, 1" Secondary's and 2 1/2" Collectors. Includes Reducer Cones which taper to 2" with gaskets and all necessary mounting hardware. Cars with larger 164 tooth 302 Bell housings may have to make minor modifications to the Header or

**WE PROUDLY FEATURE AUTHENTIC MUSTANG REPRODUCTIONS FROM SCOTT DRAKE ENTERPRISES!**



Bell Housing for proper clearance. Note some Early 289 cars have been retrofitted with larger Bell Housing.

**Exhaust Headers, Modified Tri-Y**

- 64-68 Black painted .....C5ZZ-9430-BK
- 64-68 304 Polished Stainless Steel .....C5ZZ-9430-SS

**SHORTY EXHAUST HEADERS**



Note: 64-65 Mustangs will require 1966-1970 motor mounts and brackets for proper clearance (see "Engine" category). Quality

header at an affordable price. Nickel plated.

**Exhaust Headers, Shorty**

- 64-70 15/8" shorty .....C5ZZ-9430-SH

**TRI-Y EXHAUST HEADERS**



These feature 1/4" flanges, miter cut 16 gauge tubes & are precision Mig welded to ensure a proper fit & eliminate exhaust

leaks. Comes boxed complete with premium gaskets, all necessary mounting hardware & reducer cones.

**Exhaust Headers, Tri-Y**

- 64-68 Small block, black-non high temp .....S1MS-9430-BL
- 64-68 Small block, ceramic .... S1MS-9430-C/C
- 64-68 Small block, nickel plated S1MS-9430-CR
- 64-68 Small block, unpainted .....S1MS-9430-RAW

**POWER STEERING DROP BRACKET**



A must when using Tri-Y headers on a power steering car. Lowers power steering for proper clearance when using Tri-Y

headers.

**Power Steering Drop Bracket**

- 64-70 .....DBPP-10961-A

**MANIFOLD AND COMPONENTS**

**EXHAUST MANIFOLD**



These manifolds are cast from high quality molds for proper fit and appearance. Includes exhaust flange bolts, nuts and

washers.

**Exhaust Manifold**

- 64-67 Fits 170-200 .....C30Z-9430-AR
- 64-73 Small block std .....C5ZZ-9430/1-DE
- 64-73 Small block, high performance .....C5ZZ-9430/1-B
- 68-70 Cobra Jet 428 .....C80Z-9430/1-BC
- 68-73 6 cylinder with IMCO .....D3BZ-9430-A
- 68-73 6 cylinder without IMCO ...D3BZ-9430-B

**EXHAUST MANIFOLD BOLT KIT**

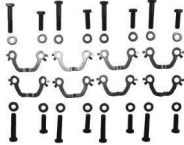

Exact copies made from the original supplier to Ford Motor Co. U.S.A. made.

Ramp-Lok features a special conical washer

designed specifically for exhaust manifolds.

**Exhaust Manifold Bolt Kit**

- 64-65 6 cylinder ..... EMB-CODE-554
- 64-65 Small block, 260-289 .... EMB-C2OE-555
- 64-65 289 High Performance .. EMB-C3OE-556
- 66-67 200 6 cylinder ..... EMB-C6DE-525
- 66-67 289 ..... EMB-C6OE-527
- 66-67 289 High Performance ... EMB-C6ZE-528
- 67-68 390 GT and GT500 ..... EMB-C7OE-539
- 68-69 390 GT, late 1968 ..... EMB-C8OE-540
- 68-69 428 Cobra Jet ..... EMB-C8OE-542
- 68-73 200, 250 6 cylinder ..... EMB-C8DE-526
- 68-73 Small block ..... EMB-C8OE-529
- 69 302, 351W ..... EMB-C9OE-530
- 69-70 Boss 429 ..... EMB-C9AE-543
- 69-70 Boss 302 ..... EMB-C9ZE-531
- 70-71 351 Cleveland 2 Barrel ... EMB-D0OE-533
- 70-71 351 Cleveland 4 Barrel ... EMB-D0OE-534
- 71 429 Cobra Jet ..... EMB-D0OE-544
- 72-73 351 Cleveland 2 Barrel ... EMB-D2OE-535
- 72-73 351 Cleveland 4 Barrel ... EMB-D2OE-536

**EXHAUST MANIFOLD GASKET**



Gasket between the cylinder head and the exhaust manifold.

**Exhaust Manifold Gasket**

- 64-68 6 cyl. w/ exhaust manifold C3DZ-9433-A
- 64-73 170, 200 w/ headers .... C3DZ-9433-HDR
- 70-73 351 Cleveland 4 Barrel ..... DOZZ-9433-B

**EXHAUST MANIFOLD GASKET KIT**

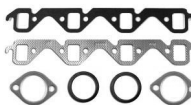

Includes exhaust manifold gaskets, pipe flange gaskets and exhaust manifold to pipe gaskets.

**Exhaust Manifold Gasket Kit**

- 64-73 260, 289, 302, 351W ..... C5ZZ-9433-A/B

**EXHAUST MANIFOLD HEAT RISER**



Tube which attaches to air cleaner and mounts to the R.H. exhaust manifold.

**Exhaust Manifold Heat Riser**

- 65-67 289 ..... C5ZZ-9A603-B
- 68-72 289, 302 ..... C8ZZ-9A603-A

**EXHAUST MANIFOLD HEAT RISER STUD**



**Exhaust Manifold Heat Riser Stud**

- 64-68 ..... 379763-S

**EXHAUST MANIFOLD HEAT SHROUD BOLT**



Screws into RH exhaust manifold.

**Exhaust Manifold Heat Shroud Bolt**

- 65-67 289 ..... 379008-S

**EXHAUST MANIFOLD LOCKING TAB**



Features zinc plating and the correct annealing for crack-free bends. Locks manifold bolts in place, prevents them from

turning.

**Exhaust Manifold Locking Tab**

- 64-65 289 HiPo, set of 8 ..... C30E-9A447-A
- 64-66 260, 289 ..... C20Z-9A447-A

**EXHAUST PIPE FLANGE GASKET**



Donut shaped gasket between the manifold and the down pipe.

**Exhaust Pipe Flange Gasket**

- 64-68 6 cylinder ..... C30Z-9450-A
- 64-73 Small block and 6 cylinder C30Z-9450-B
- 67-70 390 ..... C9ZZ-9450-D
- 69-73 351W and 351 Cleveland .. C9ZZ-9450-A

**EXHAUST PORT DIVIDER**



Smooths out air flow between #3 and #4 exhaust ports to improve economy and performance. Can be used with standard

exhaust manifold and headers. Welding recommended but not required.

**Exhaust Port Divider**

64-73 170, 200, 250 ..... C30Z-9430-EPD

**FACTORY START TUBES**



These starter tubes are specially designed to bolt to shorty headers to ease installation. Requires welding of exhaust system to

these tubes. Connects headers to exhaust system.

**Factory Start Tubes**

64-70 With carburetor connection .JBA-1650ST

64-70 With O2 sensor connection .....

JBA-1650ST-1

**PIPES, CLAMPS & BRACKETS**

**REAR UPPER EXHAUST BRACKET**



**Exhaust Bracket, Rear Upper**

65-70 Left hand, GT ..... C5Z-5277-A

65-70 Right hand, GT ..... C5Z-5277-B

**EXHAUST HANGER**

A variety of hangers to keep exhaust systems at stock positions.

**Exhaust Hanger**



65-66: Left or right hand, dual exhaust.

C5Z-5A246-D



65-68: Left hand

C5Z-5A246-A



65-68: Right hand

C5Z-5A246-B

**Exhaust Hanger**



65-69: Rear, dual

C6Z-5266-AR



70-73: Right hand, Dual exhaust

DOZZ-5260-A



70-73: Left hand, Dual exhaust.

DOZZ-5260-B

**EXHAUST HANGER INSULATOR**



This insulator does just that, it secures the pipe to the hanger and absorbs vibration. The rubber pad keeps it from rattling against

the undercarriage. For 1965 through 1969 Mustangs with V8 engines and dual factory exhaust. You need two of these.

**Exhaust Hanger Insulator**

65-70 ..... CSZZ-5260-B

**EXHAUST PIPE CLAMP**

Pipe clamps in both original and replacement styles.

**Exhaust Pipe Clamp**



65-68: Replacement type

C6Z-5A231-AR



65-69: Original (horse shoe) style

C5Z-5A231-A

**EXHAUST HANGER KIT**



These concours correct exhaust kits are easy to order and offer a savings versus buying all components individually.

**Exhaust Hanger Kit**

64-66 V8 single exhaust hanger mount kit 2 ..

CSZZ-5257-1HMK

64-66 6 cyl. exhaust hanger mount kit .....

CSZZ-5257-6HMK

65-66 Dual exhaust hanger mount kit 2 .....

CSZZ-5257-2AHMK

65-66 Dual exhaust hanger mount kit 2.25 -

Oversized ..... CSZZ-5257-2BHMK

**Exhaust Hanger Kit**

67 6 cyl. single exhaust hanger mount kit  
1.75 ..... C7ZZ-5257-1HMK

67 6/8 cyl. single exhaust hanger mount kit  
2 ..... C7ZZ-5257-2HMK

67-69 Dual exhaust hanger mount kit  
2 - Original transverse muffler  
..... C8ZZ-5257-2AHMK

67-69 Dual exhaust hanger mount kit  
2.25 - Original transverse muffler  
..... C8ZZ-5257-2BHMK

68-70 V8 single exhaust hanger mount kit 2 ....  
..... C8ZZ-5257-1AHMK

68-70 Single exhaust hanger mount kit 2.25 ....  
..... C8ZZ-5257-1BHMK

71-73 Dual exhaust hanger mount kit 2.25 -  
OEM ..... D1ZZ-5257-2HMK

**EXHAUST HANGER RETAINER**



Used on dual exhausts cars this mounts to floor under rear seat. Attaches exhaust muffler hanger to floor. Includes hardware. Not

exact copy of original.

**Exhaust Hanger Retainer**

65-70 Dual exhaust ..... CSZZ-5A247-A

**DUAL EXHAUST KIT**



Economy replacement, dual exhaust system for 1964-66 260 and 289. Can also be adapted for 1967-68 289 and 302 cars. This

kit consists of the "H" pipe, the intermediate pipes, mufflers and exhaust pipes. Made from aluminized steel. All clamps and hangers are sold separately. **Will work with either GT tips or turn downs.**

**NOTE: Not recommended for Convertibles due to very tight clearances in Transmission Tunnel at Convertible Seat Reinforcement Pans and Reinforcement Plate.**

**Modifications to fit Convertibles will most likely be required by an Exhaust Shop. See Concours Exhaust Systems for a trouble free installation.**

**Exhaust Kit, Dual**

64-66 Complete system, standard manifolds w/o resonaters, no clamps or hangers. ...

CSZZ-5246/30-K

64-66 Complete system, standard manifolds w/ GT resonaters, no clamps or hangers .....

CSZZ-5246/30-KR

Exhaust

**WE PROUDLY FEATURE AUTHENTIC MUSTANG REPRODUCTIONS FROM SCOTT DRAKE ENTERPRISES!**



**K GT EXHAUST KIT**



Complete aluminized economical exhaust system for high performance "K" 289 cu.in. Mustangs. Diameter is 2 inches.

This kit fits factory HiPo exhaust manifolds only. Available with or without resonators. Clamps & Hangers sold seperately. **Will work with either GT tips or turn downs.**

**NOTE: Not recommended for Convertibles due to very tight clearances in Transmission Tunnel at Convertible Seat Reinforcement Pans and Reinforcement Plate.**

**Modifications to fit Convertibles will most likely be required by an Exhaust Shop. See Concours Exhaust Systems for a trouble free installation.**

**Exhaust Kit, K GT**

- 64-66 Without resonators ....CSZZ-5246/30-HP
- 64-66 With resonators .....CSZZ-5246/30HPR

**CONCOURS EXHAUST SYSTEM**



We now offer the most comprehensive line of exhaust products for 1964 -1973 Mustangs and 1965-70 Shelbys. These Exhaust

products are of premium quality and made to original factory specifications in the U.S.A. All of our products have been test fitted on the appropriate Mustang prior to production to insure a trouble free installation. We use only the heaviest gauge aluminized tubing available. Mufflers have correct factory brackets when needed and are also aluminized to eliminate early rust out. All Kits are compression bent just like originals for that Concours look. H-Pipes and Hanger kits are sold separately.

**Exhaust System**

- 64-66 6 cyl. single exhaust system 1.75 .....CSZZ-5257-ARK
- 64-66 V8 single exhaust system 2 -Without resonator or Y pipe .....CSZZ-5257-BRK
- 64-66 V8 single exhaust system - Includes resonator, no Y pipe .....CSZZ-5257-DRK
- 64-69 V8 turbo exhaust system 2.25 - No H pipe .....CSZZ-5257-TTQ
- 65-66 GT exhaust system 2 - without resonator or H pipe - fits GT tips ..CSZZ-5257-WOR
- 65-66 GT exhaust system 2 - Includes resonator, no H pipe - fits GT tips .....CSZZ-5257-WRS
- 65-69 V8 Flowmaster exhaust sys 2.25 - Delta flow, no H pipe .....CSZZ-5257-FLM
- 67 289 single exhaust system 2 -without resonator or Y pipe .....C7ZZ-5257-BRK

**Exhaust System**

- 67-69 OEM Dual exhaust system 2 - Transverse single muffler .....C8ZZ-5257-CRK
- 67-69 OEM Dual exhaust system 2.25 - Transverse single muffler .....C9ZZ-5257-CRE
- 68-70 6 cyl. exhaust system 2 C8ZZ-5257-LRK
- 70 OEM Boss 302/429 exhaust sys 2.25 - Requires turn downed tips .....DOZZ-5257-BOS
- 70 OEM Mach1 exhaust sys - For staggered shock cars only 2.25"....DOZZ-5257-MCH
- 70 OEM 351/428 Mach1 exhaust sys - Without staggered shocks 2.25" .....DOZZ-5257-MWO
- 71-73 Non-Mach 2" dual exhaust sys - Requires 2.25" turn down tips ....D1ZZ-5257-ARK
- 71-73 Mach1 dual exhaust sys 2.25 - Requires Mach1 tips .....D1ZZ-5257-TRK

**EXHAUST H AND Y PIPES**



We now offer the most comprehensive line of exhaust products for 1964 -1973 Mustangs and 1965-70 Shelbys. These Exhaust

products are of premium quality and made to original factory specifications in the U.S.A. All of our products have been test fitted on the appropriate Mustang prior to production to insure a trouble free installation. Look for 289-302 "H" pipes in 2.25" Diameter Summer 2012.

**Exhaust Pipes**

- 64-66 6 cyl. exhaust head pipe 1.75 .....CSZZ-5246-D
- 64-66 260-289 single exhaust Y pipe .....CSZZ-5246-F
- 64-66 Small block, dual, Hi-Po manifolds 2" .....CSZZ-5246-K
- 64-68 Small block, dual, standard manifolds 2" .....CSZZ-5246-J
- 67 289 single exhaust Y pipe 2 .....C7ZZ-5246-A
- 67 6 cyl. exhaust pipe 2 - Automatic only ...C7ZZ-5246-J
- 67-68 390 GT exhaust H pipe 2 - Requires factory spacer .....C7ZZ-5246-M
- 68-70 200 exhaust head pipe 2 - Fits both A/T & M/T .....C8ZZ-5246-B
- 68-70 428CJ exhaust H pipe 2.25 - Requires factory spacer .....C9ZZ-5246-F
- 69 351W exhaust H pipe 2.25 C9ZZ-5246-A
- 69 390GT H exhaust pipe 2 - For use without spacer .....C9ZZ-5246-T
- 70 351C-4V exhaust H pipe 2.25 -Will not fit 2V .....DOZZ-5246-A
- 70 428CJ exhaust H pipe 2.25 - For use without spacer .....DOZZ-5246-D









**Exhaust Pipes**

- 71-73 351C-4V exhaust H pipe 2.25 .....D1ZZ-5246-FR

**EXHAUST TIPS**

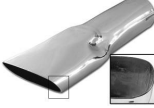
We have the largest selection of concours and economy tips to meet all your customers needs!

**Exhaust Tips**

-  65-66: GT, reproduction, economy CSZZ-5255-C/D
-  65-66: GT, concours, show quality CSZZ-5255-PRO
-  65-66: GT, 2 inch pipe, high-flow louver design. Improves flow by 20% can be expanded to 2.25". Not a direct fit for original exhaust system. CSZZ-5255-GT2
-  67-69: Original style, concours w/ correct rolled tip C7ZZ-5258-C
-  70: Mach 1, concours w/ correct rolled tip DOZZ-5255-A
-  67-70: Mach 1, economy reproduction DOZZ-5255-AR
-  71-73 D1ZZ-5225-G
-  67: Eleanor, cast aluminum, side exhaust S7MS-5255-E
-  65-66: Turn downed tips 2 reduced to 1.875 CSZZ-5257-TIP
-  67-73: Turn downed tips 2.25 C8ZZ-5257-TIP

**EXHAUST TRIM REAR VALANCE**



Beautiful addition to the rear valance, finishes off the cut out for the exhaust pipe. Ours are polished stainless steel like the

originals.

**Exhaust Trim Rear Valance**

65-66 Concours polished S/S CSZZ-5C299-A

65-66 economy Chrome .....CSZZ-5C299-AR

**6 CYL. HEAD PIPE HANGER BRACKET**



**Head Pipe Hanger Bracket, 6 Cyl.**

64-67 6 cylinder, single .....C4DZ-5291-A

**MUFFLER**



Features fully aluminized double wall construction, exact OEM dimensions and proper attaching brackets when

required. Easy to install compared to generic replacements.

**Muffler**

64-66 8 cylinder, single exhaust ..CSZZ-5230-D

64-66 6 cylinder .....CSZZ-5230-T

65-66 Dual exhaust, OEM bracket, LH or RH .....C6ZZ-5230-E

67 Small block, single exhaust C7Z-5230-A

67 6 cylinder .....C7Z-5230-D

68-70 6 cylinder 200 .....C8ZZ-5230-A

68-70 Small block, single exhaust C8Z-5230-B

69 Transverse Dual exhaust ....C9ZZ-5230-C

70 Dual exhaust, 302, 351 ..D0ZZ-5230-B/D

**FUEL SYSTEM**

**ACCELERATOR COMPONENTS**

**ACCELERATOR CABLE**



Cable link between the accelerator pedal and the linkage to the carburetor.

**Accelerator Cable**

69 302, 351, 390, and 428 ...C9ZZ-9A758-A

**Accelerator Cable**

70 302, 351 and 428 .....C9ZZ-9A758-E

**ACCELERATOR LINKAGE KIT**

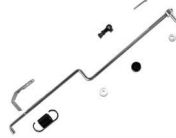

Kit comes complete with accelerator linkage rod, bushings and clip kit, return spring, and bracket.

**Accelerator Linkage Kit**

64-67 289 2 Barrel .....CSZZ-9A702-2K

64-67 289 4 Barrel .....CSZZ-9A702-4K

**ACCELERATOR LINKAGE ROD**



Rod which connects carb to main linkage. Zinc plated. Also available in chrome.

**Accelerator Linkage Rod**

64-67 Chrome .....CSZZ-9A702-C

65-67 Gold zinc .....CSZZ-9A702-D

**ACCELERATOR LINKAGE ROD BUSHING KIT**



All the necessary hardware needed for a trouble free installation. Includes rubber insulator bushing, nylon insert

bushing, cotter key, washer and carb to linkage clip.

**Accelerator Linkage Rod Bushing Kit**

64-67 .....CSZZ-9A702-MK

**ACCELERATOR MOUNTING SCREW**



A precision machined screw with exact detail. Painted black. Made by Scott Drake.

**Accelerator Mounting Screw**

64-68 .....380503-5101

**ACCELERATOR PEDAL**



These steel reinforced parts are molded from high quality rubber for a long life and great appearance.

**Accelerator Pedal**

64-68 With stainless trim .....CSZZ-9735-D

69-70 Without trim .....C9ZZ-9735-D

71-73 Without trim .....D1ZZ-9735

**ACCELERATOR PEDAL ASSEMBLY**



Replace your misaligned pedal with a new safer unit.

**Accelerator Pedal Assembly**

69 .....C9ZZ-9735-K

**ACCELERATOR PEDAL SPRING**



Made of strong spring steel for a long life. Made by Drake.

**Accelerator Pedal Spring**

64-68 .....CSZZ-9760-B

69-70 .....C90Z-9760

**ACCELERATOR RETURN SPRING**



Correct spring, black phosphorus plated.

**Accelerator Return Spring**

64-68 .....CSZZ-9737-B

**ACCELERATOR ROD GROMMET**



This is the small rubber grommet that attaches where the accelerator rod meets the linkage rod to ensure a smooth pivot without sticking.

**Accelerator Rod Grommet**

64-69 .....379009-5

**PEDAL PIVOT ASSEMBLY**

Better quality and fit. Painted detail gray. New lower price. Mixing not allowed for price break. New Lower Price!

**Pedal Pivot Assembly**



64-68: 64-65: 260, 289 All ; 66-68: 289, 302 Manual CSZZ-9725-A



66-68: 66-68: 289, 302 Automatic C6ZZ-9725-

**WE PROUDLY FEATURE AUTHENTIC MUSTANG REPRODUCTIONS FROM SCOTT DRAKE ENTERPRISES!**



**RETURN SPRING BRACKET**



Neat detail item, stamped steel with zinc plating.

**Return Spring Bracket**

64-65	Bell crank	.....	C5ZZ-9741-K
64-66	4 Barrel	.....	C5ZZ-9741-C
64-68	2 Barrel	.....	C3AZ-9741-A
65-66	2 Barrel	.....	C5ZZ-9741-A

**KICK DOWN CABLE**



Kick Down Cable - 10.2" long. Fits 6 cylinder and V8.

**Kick Down Cable**

66-68	.....	C60Z-7A187-D
-------	-------	--------------

**TRANSMISSION KICK DOWN CABLE KIT**

**KIT**



A 9-piece kit, our Transmission Kick Down Cable Kit includes our cable, lever, spring & bracket, along with all the

hardware for simple installation.

**Transmission Kick Down Cable Kit**

66-68	.....	C60Z-7A187-KIT
-------	-------	----------------

**CARBURETOR COMPONENTS**

**CARBURETOR ACCELERATOR PUMP**



This Diaphragm Pump mounts on the front all 64-73 Autolite 2V carbs as well as 64-67 Autolite 4V Carbs. With today's

Gas these commonly fail, especially when sitting for extended periods of time. Complete failure will cause dangerous fuel leaks, but many times these will affect performance well before a leak actually starts. Good idea to replace every 2-3 years or if sitting for 6 months or more.

**Carburetor Accelerator Pump**

64-73	2V/4V V8	.....	C4AZ-9B559-A
-------	----------	-------	--------------

**CARBURETOR SPACER**

A nice reproduction of a part that is commonly in need of replacement.

**Carburetor Spacer**



64-68:	6 cylinder	.....	C3UZ-9A589-B
--------	------------	-------	--------------



65-68:	289 4 barrel	.....	C30Z-9A589-C
--------	--------------	-------	--------------

**CARBURETOR SPACER GASKET**



The gasket that goes between the spacer and the manifold and between the manifold and carburetor.

**Carburetor Spacer Gasket**

64-66	4 Barrel	.....	C2AZ-9447-E
64-73	2 Barrel	.....	C3AZ-9447-B
64-73	6 Cylinder	.....	C3DZ-9447-A
67-70	4 Barrel	.....	C7ZZ-9447-A
67-70	4 Barrel	.....	C7ZZ-9447-D3
67-70	4 Barrel	.....	C7ZZ-9447-D4
70-73	2 Barrel	.....	D0ZZ-9447-C2

**CHOKE/HEAT RISER AND RELATED**

**CHOKE CABLE**



This is the exact replacement for the manual choke cable. Mounting hardware is included. Originally built for High

Performance 289.

**Choke Cable**

65-66	.....	C5ZZ-9700-AR
-------	-------	--------------

**CHOKE THERMOSTAT SHIELD**



This stamped steel part bolts to carburetor and holds heater hose against choke.

**Choke Thermostat Shield**

65-69	.....	C5ZZ-9861
-------	-------	-----------

**CHOKE TUBE KIT**

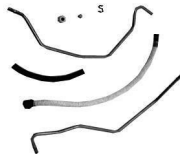

We have these steel tubes made for us to exacting O.E.M. standards and specifications. All choke tubes have the

proper fiberglass insulation, fittings, rubber hose, and S-clip. Also includes cold air tube when applicable. A part# ending in "S" denotes stainless steel.

**Choke Tube Kit**

64-69	64-69:	170, 200	.....	MCT003			
64-69	64-69:	170, 200	Stainless	..... MCT003S			
70	70:	200	.....	MCT004			
70	70:	200	Stainless	..... MCT004S			
64-73	64-73:	260, 289, 302, 2 BBL.	64-66:	260, 289-2 or 4 BBL. 69:	351W-2BBL	.....	MCT001
64-73	64-73:	260, 289, 302, 2 BBL.	64-66:	260, 289-2 or 4 BBL. 69:	351W-2BBL	Stainless	..... MCT001S
67-68	67:	"A" code, 289, 4 BBL. 68:	"J" code, 302, 4 BBL.	.....	MCT008		
67-68	67:	"A" code, 289, 4 BBL. 68:	"J" code, 302, 4 BBL. Stainless	.....	MCT008S		
67-68	67-68:	390, Big block	.....	MCT002			
67-68	67-68:	390, Big block	Stainless	.....	MCT002S		
67	67:	428, dual 4 BBL., Shelby only	.....	MCT007			
67	67:	428, dual 4 BBL., Shelby only	Stainless	.....	MCT007S		
68-69	68-69:	428 CJ	.....	MCT009			
68-69	68-69:	428 CJ	Stainless	.....	MCT009S		
69-70	69:	351W, 4 BBL. 70:	351, 4 BBL., Shelby	.....	MCT005		
69-70	69:	351W, 4 BBL. 70:	351, 4 BBL., Shelby	Stainless	.....	MCT005S	
69	69:	351W, 2 barrel	.....	MCT013			
70-73	70-73:	2 BBL., 4 BBL.	.....	MCT011			
70-73	70-73:	2 BBL., 4 BBL. Stainless	.....	MCT011S			
64-73	64-73:	Universal kit for headers	.....	MCT014			

**FUEL FILTERS, PUMPS, & SENDING UNITS**

**FUEL FILTER**

Filters protect your carburetor from costly repairs by trapping dirt. For original carburetor's only. Please confirm thread size you need.

**Fuel Filter**



64-65:	Element	.....	C4AZ-9365-B
--------	---------	-------	-------------



64-73:	5/16"	.....	W89258B
--------	-------	-------	---------

**Fuel Filter**



64-73: 3/8"  
W89418B



65-73: In line  
C2RZ-9155-A



66-67: V8, w/ 7/16" threads  
CSAZ-9155-B



66-73: 6-cyl. and Small Block  
D30Z-9155-B



68-71: Boss and Big Block  
D3AZ-9155-C

**SENDING UNIT FUEL FILTER**



Replaceable filters which attaches to original fuel sending unit.

**Fuel Filter, Sending Unit**

64-73 3/8"	.....D1AZ-9A011-A
64-73 5/16"	.....D1FZ-9A011-A
69	.....C9ZZ-9275-SS
70	.....D0ZZ-9275-SS
71	.....D1ZZ-9275-SS

**FUEL HOSE**



Quality U.S.A. made hose with concurs repeating GAS markings. Also include OEM mounting hardware.

**Fuel Hose**

64-68 5/16"	.....C5ZZ-9327-A
67-73 3/8"	.....C7ZZ-9327-A

**FUEL PUMP**



These original style diaphragm pumps are all-new, not rebuilt. Includes mounting gasket. Not concurs.

**Fuel Pump**

64-65 170, 200 and 240 engines	.....C3AZ-9350-Y
64-65 Early 260 and 289	.....C50Z-9350-A

**Fuel Pump**

66-67 289	.....C5AZ-9350-B
66-67 200 6 cylinder	.....C5UZ-9350-C
67 390	.....C6AZ-9350-B
68-69 390	.....D8TZ-9350-C
68-70 428 engine	.....C7AZ-9350-A
68-73 200 and 250 6 cylinder	.....D3TZ-9350-A
70-73 351 Cleveland	.....D7SZ-9350-C

**FUEL PUMP FILTER CANISTER**

Concourse correct, and quality reproduction with silk-screened logo and authentic markings.

**Fuel Pump Filter Canister**



64-66  
C3AZ-9355-G



64-66: White, original fit  
C3AZ-9355-A

**FUEL PUMP MOUNTING GASKET**

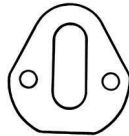

Always replace this gasket when replacing the fuel pump. Made in the U.S.A.

**Fuel Pump Mounting Gasket**

64-73	.....C3AZ-9417-C
-------	------------------

**FUEL PUMP REBUILD KIT**



Use this kit to rebuild your original Carter fuel pump on your Boss 302, Boss 429, 428PI, 428CJ or 429 SCJ. This kit will work

only on pumps with a screw together body.

**Fuel Pump Rebuild Kit**

67-73	.....C7AZ-9349-A
-------	------------------

**FUEL TANK SENDING UNIT**



Complete sending unit with either original brass float or economy plastic float. Gasket included. Does not include retaining ring.

Scott Drake's commitment to service includes inspecting, pressure testing and performing an OHMS test on 100% of our sending units to help assure a trouble free installation. Features zinc plated steel construction.

**Sending Unit, Fuel Tank**

64-67 Steel, 5/16" tube, brass float	.....C5ZZ-9275-BR
--------------------------------------	-------------------

**Sending Unit, Fuel Tank**

64-67 Stainless steel, 5/16" tube, float	.....C5ZZ-9275-C
64-67 Zinc plated steel, 5/16" tube, plastic float	.....C8ZZ-9275-CR
64-68 Zinc plated steel, 3/8" tube, plastic float	.....C8ZZ-9275-CR
64-68 Stainless steel, 3/8" tube	.....C8ZZ-9275-C
64-68 Steel, 3/8" tube, brass float	.....C8ZZ-9275-BR
69 Zinc plated steel, plastic float	.....C9ZZ-9275-C
70 Zinc plated steel, plastic float	.....D0ZZ-9275-C
71-73 Zinc plated steel, plastic float	.....D1ZZ-9275-C

**SENDING UNIT FLOAT**



Correct brass float with original style construction. Lasts longer than cheap plastic floats available on many imported fuel

senders. Plastic floats commonly leak causing premature fuel gauge failure.

**Sending Unit Float**

64-73 Brass	.....C0AZ-9202-B
-------------	------------------

**SENDING UNIT GASKET**



**Sending Unit Gasket**

64-73	.....C0AF-9276-A
-------	------------------

**SENDING UNIT RETAINING RING**



Our reproduction ring features original fit and the same heavy duty steel construction as the original.

**Sending Unit Retaining Ring**

64-73	.....C0AZ-9A307-B
-------	-------------------

**FUEL LINES**

**BRAKE AND FUEL LINE CLIP KIT**



Convenient kit which mounts front to rear gas lines and long brake line. Kit includes all clips, fasteners and instructions.

**Brake And Fuel Line Clip Kit**

64-67	.....380374-MK
-------	----------------

**WE PROUDLY FEATURE AUTHENTIC MUSTANG REPRODUCTIONS FROM SCOTT DRAKE ENTERPRISES!**





**PUMP TO CARBURETOR FUEL LINE**



These reproduction fuel lines are exact duplicates of the originals, and feature all the correct fittings. Available in original

steel or corrosion resistant stainless steel.

**Fuel Line, Pump To Carburetor**

64-65	170	.....MGL006
64-65	170, stainless	..... MGL006S
66-67	200	.....MGL004
66-67	200, stainless	.....MGL004S
68-70	200	.....MGL017
68-70	200, stainless	..... MGL017S
64	260	.....MGL003
64	260, stainless	.....MGL003S
65	289	.....MGL001
65	289, stainless	..... MGL001S
66-67	289	.....MGL002
66-67	289, stainless	.....MGL002S
64-65	289 with Holley	.....MGL011
64-65	289 with Holley, stainless	.....MGL011S
66-67	289 with Holley 715	.....MGL021
66-67	289 with Holley 715, stainless	..MGL021S
67-70	390, 428 police interceptor	.....MGL007
67-70	390, 428 police interceptor, stainless	..... MGL007S
67	390 2 barrel	.....MGL014
67	390 2 barrel, stainless	.....MGL014S
67	390 4 barrel	.....MGL015
67	390 4 barrel, stainless	.....MGL015S
67	428 8 barrel	.....MGL020
67	428 8 barrel, stainless	.....MGL020S
68	302 4 barrel	.....MGL022
68	302 4 barrel, stainless	.....MGL022S
68-70	289, 302 2 barrel	.....MGL005
68-70	289, 302 2 barrel, stainless	.....MGL005S
69	351, 4 barrel	.....MGL009
69	351, 4 barrel, stainless	.....MGL009S
69-70	Boss 302	.....MGL010
69-70	Boss 302, stainless	.....MGL010S
69-70	Boss 429	.....MGL008
69-70	Boss 429, stainless	.....MGL008S
70-73	351 Cleveland 2 barrel	.....MGL016
70-73	351 Cleveland 2 barrel, stainless	..... MGL016S
70-73	351 4 barrel	.....MGL013
70-73	351 4 barrel, stainless	.....MGL013S
70-73	429 Cobra Jet	.....MGL018
70-73	429 Cobra Jet, stainless	.....MGL018S
70-73	429 Super Cobra Jet	.....MGL019
70-73	429 Super Cobra Jet, stainless	..MGL019S
71	302 2 bbl., stainless	..... MGL024S
71	302 2 bbl.	.....MGL024
71	Boss 351 Cleveland, stainless	..MGL023S
71	Boss 351 Cleveland	.....MGL023

**TANK TO PUMP FUEL LINE**



Features corrosion resistant lines with the correct fittings. Because of their long length, all lines are gently bent so they are

FedEx shippable. These are easily straightened upon receipt.

**Fuel Line, Tank To Pump**

64-67	6 cylinder, 5/16, 1 piece (64- Early 67) ....	MLG004
64-67	6 cylinder, 5/16, 1 piece, stainless (64- Early 67) .....	MLG004S
67	6 cylinder, 5/16, 2 piece .....	MLG007
67	6 cylinder, 5/16, 2 piece, stainless .....	MLG007S
68-70	6 cylinder, 3/8, 2 piece .....	MLG008
68-70	6 cylinder, 3/8, 2 piece, stainless .....	MLG008S
71-73	6 cylinder, 5/16, 1 piece .....	MLG010
71-73	6 cylinder, 5/16, 1 piece, stainless .....	MLG010S
64-67	8 cylinder, 5/16, 1 piece .....	MLG002
64-67	8 cylinder, 5/16, 1 piece stainless .....	MLG002S
65-66	Larger (3/8") for high performance cars (Shelby) .....	MLG012
67	8 cylinder, 5/16, 2 piece .....	MLG003
67	8 cylinder, 5/16, 2 piece, stainless .....	MLG003S
68	8 cylinder, 3/8, 2 piece Except cars with staggered shocks .....	MLG009
68	8 cylinder, 3/8, 2 piece, stainless, except cars with staggered shocks .....	MLG009S
68-70	8 cylinder, 3/8, 2 piece, with staggered shocks, including Boss302 and Boss 429 .....	MLG001
68-70	8 cylinder, 3/8, 2 piece, with staggered shocks, including Boss 302 and Boss 429, stainless .....	MLG001S
69-70	8 cylinder, 3/8, 2 piece .....	MLG005
69-70	8 cylinder, 3/8, 2 piece, stainless .....	MLG005S
71-73	8 cylinder, 3/8, 2 piece .....	MLG006
71-73	8 cylinder, 3/8, 2 piece, stainless .....	MLG006S
71-73	8 cylinder, 5/16, 1 piece, with vapor return line .....	MLG011
71-73	8 cylinder, 5/16, 1 piece, with vapor return line, stainless. ....	MLG011S

**FUEL LINE BRACKET**



Mounts to the drivers side of the water pump to secure fuel line on its path to the carburetor.

**Fuel Line Bracket**

64-65	Zinc .....	C5ZZ-9D319
66	Plain .....	C6ZZ-9D319

**FUEL LINE GROMMET**

This is the grommet that protects the fuel line as it passes through the driver's side inner fender panel.

**Fuel Line Grommet**



71-73: Two-hole  
D1ZA-9K288-AA



71-73: 3/8", one-hole  
D1ZZ-9288

**FUEL TRANSFER LINE**



This line transfers fuel from the front fuel bowl to the rear fuel bowl on Holley carburetors.

**Fuel Transfer Line**

64-67	715 Holley .....	MGL012
64-67	715 Holley, stainless steel .....	MGL012S

**FUEL TANKS AND COMPONENTS**

**FUEL FILLER TUBE**



Fuel inlet filler tube. Perfect copy of the original. Plated to stop corrosion.

**Filler Tube, Fuel**

64-66	.....	C5ZZ-9034-B
67-68	.....	C7ZZ-9034-A
69	.....	C9ZZ-9034-A
70	Without California emissions .....	D0ZZ-9034-A

### FUEL FILLER FLANGE GASKET

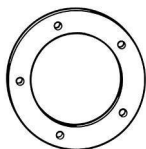

These reproduction seals are made from fuel resistant cork and are perfect replacements for restorations or service.

Will prevent fuel spills or water from entering the trunk area via the filler tube flange.

**Fuel Filler Flange Gasket**  
64-71 ..... CSZZ-9076-A

### FUEL FILLER HOSE



American made fuel resistant rubber. Perfect fit. Available with red stripes and Autolite logo.

**Fuel Filler Hose**  
64-67 4 inch, all black ..... C4GY-9047-A  
64-67 With Autolite logo ..... C4GY-9047-AL  
65-70 6 inch, all black, without California emissions ..... C8ZA-9047  
68-70 With logo, 70 without California emissions ..... C8ZA-9047-AL

### FUEL FILLER PIPE TO TRUNK FLOOR SEAL



**Fuel Filler Pipe To Trunk Floor Seal**  
71-73 ..... D1ZZ-9008

### FUEL PIPE HOSE CLAMP



Original style wire clamps for retaining the filler hose to the tank standpipe and filler neck.

**Fuel Pipe Hose Clamp**  
64-70 ..... CSZZ-8287

### STAINLESS STEEL FUEL TANK



Quality stainless steel gas tank for years of rust free service. Has drain plug 20 gallon capacity.

**Fuel Tank**  
64-68 Stainless steel, has drain plug ..... CSZZ-9002-SS  
69 Stainless steel, has drain plug ..... C9ZZ-9002-SS  
70 Stainless steel, with drain plug ..... DOZZ-9002-SS

### FUEL TANK

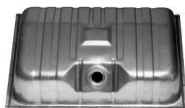

These hand crafted North American gas tanks use industry standard Ni-Terne steel. This high liability part is backed by a

company known for leading the industry in safety and craftsmanship. Seam welded and pressure tested under water twice for integrity. Each tank has a 3 year warranty by the manufacturer. New retaining ring and gasket included. 1 year warranty on Imports. **Fuel Tank Made in the U.S.A.**

64-68 With drain plug ..... CSZZ-9002-D1A  
64-68 Without drain plug ..... CSZZ-9002-D2A  
69 20 gallon capacity ..... C9ZZ-9002-A  
70 22 gallon capacity, without California emissions ..... DOZZ-9002-A  
71-73 ..... D1ZZ-9002

### Fuel Tank Imported

64-68 With drain plug ..... CSZZ-9002-DI  
69 ..... C9ZZ-9002-AI  
70 ..... DOZZ-9002-AI

### FUEL TANK FILLER KIT



This convenient kit saves time and money.

**Fuel Tank Filler Kit**  
64-67 ..... KIT-FUL-1

### FUEL TANK FILLER MOUNT SCREW



Special sheet metal screws used to attach filler tube to tail lamp panel. Cadmium plated. Screw on fuel caps only, not for pop

open type.  
**Fuel Tank Filler Mount Screw**  
64-68 Set of 5 ..... 42120-SK

### FUEL TANK MOUNTING KIT



Includes eleven cadmium plated sheet metal screws, one black oxide captive washer bolt, and one "J" plate nut.

**Fuel Tank Mounting Kit**  
64-68 ..... CSZZ-9002-MK

## GAS CAPS

### ELEANOR GAS CAP CONVERSION KIT



#### KIT

This kit is used to relocate the gas cap to the driver's side "B" pillar as typically seen on Eleanor Mustangs. Kit includes everything

needed for an authentic conversion.  
**Eleanor Gas Cap Conversion Kit**  
67-68 ..... S7MS-9030/9034K

### GAS CAP

\*  Made by Scott Drake, authentic Concours Mustang Gas Caps! Made in the U.S.A., these gas caps are the best on the market, far superior to import reproductions. These caps also feature a security cable on back to prevent theft. Officially licensed by Ford.  
**Gas Cap**



64: No cable\*  
CSZZ-9030-A



65: With cable\*  
CSZZ-9030-B



65: T5\*  
CSZZ-9030-C



66: GT\*  
C6ZZ-9030-A



66: Standard\*  
C6ZZ-9030-B



67: Standard\*  
C7ZZ-9030-A



67: GT pop open  
C7ZZ-9030-B



67: GT Twist on  
C7ZZ-9030-C

**WE PROUDLY FEATURE AUTHENTIC MUSTANG REPRODUCTIONS FROM SCOTT DRAKE ENTERPRISES!**



**Gas Cap**



67: Deluxe pop open\*  
C7ZZ-9030-D



67-68: w/out emblem, use w/  
original emblem or our 67-68 Shelby  
emblems below  
C7ZZ-9030-WOE



67: GT350 Emblem only  
S7MS-9030-350



67: GT500 Emblem only  
S7MS-9030-500



68: GT350/500 Emblem only  
S8MS-9030-E



68: GT500KR Emblem only  
S8MS-9030-KRE



68: Standard twist on\*  
C8ZZ-9030-A



68: Deluxe pop open\*  
C8ZZ-9030-C



68: GT pop open  
C8ZZ-9030-D



69: Standard twist on\*  
C9ZZ-9030-A



69: Deluxe pop open\*  
C9ZZ-9030-C



70: Non vented\*  
D0ZZ-9030-D

**Gas Cap**



70: Deluxe pop open\*  
D0ZZ-9030-E



69: GT Deluxe pop open\*  
C9ZZ-9030-B



71-73: Vented, no cable\*  
D1ZZ-9030-A



71-73: Vented with cable\*  
D1ZZ-9030-B



71-73: Mach 1  
D1ZZ-9030-C



66: Shelby GT-350\*  
S2MS-9030-A

**ALUMINUM BILLET GAS CAP**

\*   The perfect finishing touch for your "Resto-Mod". Machined from a solid block of billet aluminum. Features our black button head screws and our quality internal components. Security cable included to deter theft. Available with several types of emblems and also in black anodized. Will not fit 1970 cars with California emissions.

**Gas Cap, Aluminum Billet**



64-73: Cobra emblem\*  
B-9030-COBRA



64-73: GT emblem  
B-9030-GT



64-73: Horse emblem\*  
B-9030-H

**Gas Cap, Aluminum Billet**



64-73: Plain  
B-9030-P

**BLACK ALUMINUM BILLET GAS CAP**

\*   The perfect finishing touch for your "Resto-Mod". Machined from a solid block of billet aluminum. Features our own silver button head screws and our quality internal components. Security cable included to deter theft. Available in natural finish and with several styles of emblems. Will not fit 1970 cars with California emissions.

**Gas Cap, Black Aluminum Billet**



64-73: Cobra emblem\*  
B-9030-COBRA-BK



64-73: GT emblem  
B-9030-GT-BK



64-73: Horse emblem\*  
B-9030-H-BK



64-73: Plain  
B-9030-P-BK

**LOCKING GAS CAP**

\*  This original looking cap features a hidden key slot beneath a flip-up cover. Will not fit: 67-70 Shelby's, 68 GT/CS, 70 Mach 1 or any 1970 with California Emission Control.

**Gas Cap, Locking**



65-73 \*  
CSZZ-9030-L

**GAS CAP LOCK**

A unique way to stop gas cap theft. Works with twist off type gas caps only. Assembly required.

**Gas Cap Lock**

64-66 .....ACC-9030-LOCK

# GRILLE

## FOG LIGHT BARS & BRACKETS

### FOG LIGHT BAR

We believe that we offer the best quality at a price that is reasonable and competitive. Ours are just like the originals - these are pressure die cast in zinc. This process is very expensive, but is the only way to produce a part with high detail and a smooth polished finish, which is the first step toward a superior chrome job.

#### Fog Light Bar



65  
CSZZ-8390-D/E



66  
C6ZZ-8390-A/B

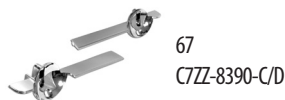

67  
C7ZZ-8390-C/D

### FOG LIGHT BAR BRACKET

Mounts to grill, helps support fog lamps. Good quality steel stampings.

#### Fog Light Bar Bracket



65: GT  
CSZZ-15266/7-A



66: GT  
C6ZZ-15266-A



67: GT  
C7ZZ-15266/7-A



68: GT  
C8ZZ-15266/7-A

### FOG LIGHT HOUSING ASSEMBLY



These Fog Light Housing Assemblies are the best on the market. Assemblies include triple chrome-plated rims, silver

painted housings on back, an exact copy of the wiring harness, cup mounting washer, and serrated flange nut. They also feature the correct wire exit and drain hole. Bulb not included.

#### Fog Light Housing Assembly

65-67 Concours correct ..... C5RZ-15200-A

68 Without correct wire pigtail .....  
C8ZZ-15200-A

68 Blue plug, concours correct .....  
C8ZZ-15200-AC

68 w/out crossbar, w/out correct wire pigtail  
C8ZZ-15200-SPEC

## GRILLE PANEL & COMPONENTS

### GRILLE



Perfect attention to detail. These grilles are perfect replacements

for previously hard to find parts.

#### Grille

64-65 Standard ..... CSZZ-8200-CR

64-65 GT, for fog lights ..... C5ZZ-8200-DR

66 All ..... C6ZZ-8200-AR

67 ..... C7ZZ-8200-AR

68 ..... C8ZZ-8200-AR

69 Black plastic ..... C9ZZ-8200-A

70 Without Sport Lights ..... D0ZZ-8200-A

70 Mach 1 ..... D0ZZ-8200-B

70 Mach 1, reproduction ..... D0ZZ-8200-BR

71-72 Mach 1, With stainless steel moldings\* ..  
D1ZZ-8200-C

71-72 Standard, moldings not included .....  
D1ZZ-8200-DR

73 Standard ..... D3ZZ-8200-A

73 Mach 1 ..... D3ZZ-8200-B

73 Mach 1, reproduction ..... D3ZZ-8200-BR

### BILLET GRILLE



These beautiful billet grilles mount in the existing grill location and look awesome.

#### Grille, Billet

64-66 ..... CSZZ-8200-BLT

65-66 Lower, for R code car with no bumper ....  
CSZZ-8200-RLB

#### Grille, Billet

65-66 Lower, for R code car with bumper style .  
CSZZ-8200-SLB

67-68 ..... C7ZZ-8200-BLT

67-68 Eleanor upper and lower .. S7MS-8200-E

69 Billet, polished ..... C9ZZ-8200-BLT

### BILLET GRILLE EMBLEM

#### MOUNTING CLIPS



These steel clips are specially designed to mount the CSZZ-16229-B Running Horse Fender Emblem to a billet grille.

#### Billet Grille Emblem Mounting Clips

64-11 ..... CSZZ-16229-BGMC

### GRILLE BAR

Our grille bars are pressure die-cast for precision and a perfect fit. Excellent plating and durability, just like the originals. Includes mounting hardware.

#### Grille Bar



64-65  
CSZZ-8390-B/C



67  
C7ZZ-8390-B/C

### GRILLE BAR MOUNTING BRACKET

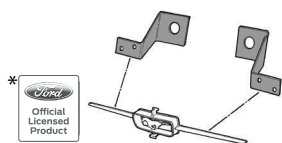

Stamped steel brackets that attach grill bars to grill. Painted black as original.

#### Grille Bar Mounting Bracket

64-65 Painted black\* ..... CSZZ-8182/3-A

### GRILLE CORRAL

Perfect reproductions with show-quality chrome!

#### Grille Corral



68: Small corral  
C8ZZ-8213-A



68: Large outer corral  
C8ZZ-8419-A

Grille

**WE PROUDLY FEATURE AUTHENTIC MUSTANG REPRODUCTIONS FROM SCOTT DRAKE ENTERPRISES!**



### Grille Corral



71-72: Standard grille  
D1ZZ-8419-A



73  
D3ZZ-8419-A

### GRILLE CORRAL AND HORSE

\* Beautiful copy of the original, with Show quality chrome. Made by Scott Drake.

#### Grille Corral And Horse



64-65: Standard or GT\*  
CSZZ-8213-AR



64-65: Blem\*  
CSZZ-8213-BLEM



66: Standard\*  
C6ZZ-8213-A



66: GT\*  
C6ZZ-8213-B



67\*  
C7ZZ-8213-A

### GRILLE CORRAL AND HORSE KIT

We have combined our beautifully chromed grille horse and small grille corral in one convenient package. Mounting hardware included.

#### Grille Corral And Horse Kit

68 \* ..... C8ZZ-8213/224-A

### GRILLE CORRAL LED LIGHT KIT



Add some flair to the front of your Mustang with a Grille Corral that lights up. Our kits work with your existing 1964-67 Corral and Running Horse emblem. Kits include back

reflector panel, waterproof LED modules, and electrical connectors. Simple installation with flexible wiring options. Grille Corral and Horse available separately from Scott Drake (part #'s C5ZZ-8213-AR, C6ZZ-8213-A, & C7ZZ-8213-A).

#### Grille Corral LED Light Kit

64-65 ..... C5ZZ-8213-LED  
66 ..... C6ZZ-8213-LED  
67 ..... C7ZZ-8213-LED

### GRILLE EMBLEM

Perfect detail. Mounting hardware included.

#### Grille Emblem

69 Running horse\* ..... C9ZZ-8213-AR  
70 Running horse\* ..... D0ZZ-8213-A

### GRILLE HORSE

A brilliant chrome running horse for the standard grille. These are all show-quality. See "Emblem" category for grille emblems.

#### Grille Horse

64-66 \* ..... C5ZZ-8A224-B  
67 \* ..... C7ZZ-8A224-A  
68 \* ..... C8ZZ-8A224-A  
71-72 \* ..... D1ZZ-8213-A  
71-73 Running horse with tribar, for Mach 1\* ...  
D1ZZ-8213-B

### GRILLE LATCH TOP PLATE

A nice reproduction. Painted black.



#### Grille Latch Top Plate

64-65 ..... C5ZZ-8194-A

### GRILLE SUPPORT BRACKET

#### Grille Support Bracket

64-66: Black  
C5ZZ-8390-FR



69  
C9ZZ-8182-A

### Grille Support Bracket



70  
D0ZZ-8232-A

## MOLDING & TRIM

### GRILLE MOLDING



'64-'66 version  
Fits on outside of grill opening. 64-70 molding includes mounting hardware. For all 71-73 molding, mounting clips are

sold separately.

#### Grille Molding

64-66 Right hand, wide ..... C5ZZ-8242-AR  
64-66 Left hand, wide ..... C5ZZ-8243-AR  
67-68 Right hand, wide ..... C7ZZ-8190-AR  
67-68 Left hand, wide ..... C7ZZ-8191-AR  
67-68 Right hand, narrow ..... C7ZZ-8242-AR  
67-68 Left hand, narrow ..... C7ZZ-8243-AR  
69 Lower grille panel ..... C9ZZ-8221-A  
69 Right hand, wide ..... C9ZZ-8242-AR  
69 Left hand, wide ..... C9ZZ-8243-AR  
69 Right hand, narrow ..... C9ZZ-8242-BR  
69 Left hand, narrow ..... C9ZZ-8243-BR  
69 Center, narrow ..... C9ZZ-8419-AR  
70 Center, wide, Lower ..... D0ZZ-8221-A  
71-72 Upper or lower ..... D1ZZ-8419-B  
71-72 Right hand ..... D1ZZ-8419-C  
71-72 Left hand ..... D1ZZ-8419-E  
73 Right hand ..... D3ZZ-8242-A  
73 Left hand ..... D3ZZ-8243-A  
73 Upper or lower ..... D3ZZ-8419-C

### GRILLE MOLDING JOINT COVER

Our own reproduction. Chrome is better than original, recessed area is painted Argent Silver. All necessary fasteners are included.

#### Grille Molding Joint Cover



66: Center  
C6ZZ-8221-A



67-68: Center Joint Cover  
C7ZZ-8221-AR

# HARDWARE

## ENGINE & ENGINE COMPARTMENT HARDWARE

### AIR CLEANER TO SNORKLE NUT

Attaches snorkle to air cleaner. Zinc plated.



**Air Cleaner To Snorkle Nut**  
64-67 ..... 358462-S7

### AIR CLEANER WING NUT

A nice reproduction.



**Air Cleaner Wing Nut**  
64-68 6 cylinder with stud ..... 383132-S  
64-73 1/4-20 thread wing nut ..... 358871-S

### BATTERY CLAMPBOLT KIT

Bolt to secure the battery in the tray.



**Battery Clamp Bolt Kit**  
67-70 ..... DOAZ-10756-A

### CARBURETOR MOUNTING NUT

Exact copies, not off the shelf standards. Thin design nut like originals. Mounts carb to intake. 4 Piece Set.



**Carburetor Mounting Nut**  
64-73 ..... MCN001

### CLUTCH FAN BOLT

4 piece set.



**Clutch Fan Bolt**  
66-73 ..... C5OE-1804

### ENGINE MASTER FASTENER KIT



These excellent kits include original equipment hardware. These high quality fasteners have been re-tooled and are made

identical to the original. Each kit includes hardware to attach the following: valve covers, air cleaner, intake manifold, oil pan, timing cover, water pump, crank pulley, thermostat housing, heat shield, distributor, carburetor, exhaust manifolds, fuel pump, oil filter adapter, engine tag and ignition coil.

#### Engine Master Fastener Kit

64 Small block with generator and air conditioner ..... EMK-C2OE-336

64 Small block High Performance with generator and air conditioner ..... EMK-C3OE-323

64-65 Small block with generator, includes exhaust locks ..... EMK-C2OE-322

65 Small block 289 with aluminum water pump and alternator .... EMK-C5OE-559

65 Small block 289 with air conditioning .... EMK-C5OE-560

65 Small block 289 High Performance with aluminum water pump and alternator .. EMK-C5OE-561

65 Small block 289 with cast iron water pump and alternator .... EMK-C5OE-812

65 Small block 289 High Performance with cast iron water pump and alternator .... EMK-C5ZE-1067

65 Small block GT-350 ..... EMK-S1ME-1184

66 6 cylinder ..... EMK-C6DE-320

66 Small block 289 with cast iron water pump and air conditioner and Ramp-locs EMK-C6OE-337

66 Small block GT-350 ..... EMK-S2ME-1185

66-67 Small block 289 with cast iron water pump and Ramp-locs ... EMK-C6OE-324

66-67 Small block 289 High Performance with cast iron water pump and Ramp-locs .... EMK-C6OE-325

67 Big block 390 GT ..... EMK-C7OE-330

67 Small block 289 with air conditioner ..... EMK-C7OE-562

67 Small block GT-350 ..... EMK-S7ME-1186

67 Big block GT-500 ..... EMK-S7ME-331

68 Small block 289, 302 ..... EMK-C8OE-326

68 Big block 428 Cobra Jet .. EMK-C8OE-333

68 Small block 289, 302 with air conditioner EMK-C8OE-338

68 Small block GT-350 ..... EMK-S8ME-1187

68 Big block GT-500KR and 428 Cobra Jet ... EMK-S8ME-382

68 Big block GT-500 ..... EMK-S8ME-677

68-69 Big block 390 GT ..... EMK-C8OE-332

68-70 6 cylinder ..... EMK-C8DE-321

### Engine Master Fastener Kit

69 Small block 302 ..... EMK-C9OE-1126

69 Small block 351 ..... EMK-C9OE-1128

69 Small block 351 with air conditioner .... EMK-C9OE-1129

69 Small block Boss 302 .... EMK-C9ZE-1180

69 Small block 302 ..... EMK-D0OE-1130

69-70 Big block 429 and Boss 429 ..... EMK-C9AE-1182

69-70 Small block GT-350 without air conditioner ..... EMK-C9OE-1188

69-70 Big block 428 Cobra Jet and Super Cobra Jet ..... EMK-C9OE-334

69-73 6 cylinder 250 ..... EMK-C9DE-342

69-73 Small block 302 with air conditioner .... EMK-C9OE-1127

70 Small block 351W ..... EMK-D0OE-1132

70 Small block Boss 302 .... EMK-D0ZE-1181

70-71 Small block 351 Cleveland with 2 barrel carburetor ..... EMK-D0OE-1175

70-71 Small block 351 Cleveland with 4 barrel carburetor ..... EMK-D0OE-1176

71 Boss 351 ..... EMK-D0OE-1177

72-73 Small block 351 Cleveland with 2 barrel carburetor ..... EMK-D2OE-1178

72-73 Small block 351 Cleveland with 4 barrel carburetor ..... EMK-D2OE-1179

### FAN SPACER BOLT KIT



**Fan spacer bolt kit**  
64-73 Silver zinc ..... 379205-K

### HEATER CABLE CLAMP BRACKET KIT

#### KIT

Secures cable to heater control assembly, heater plenum and heater box. Black oxide bracket with screw.



**Heater Cable Clamp Bracket Kit**  
64-68 ..... 378897-S

### HEATER HOSE CLAMP

Designed for any one-inch hose, this clamp can be used for the breather hose between the valve cover and air cleaner



on 1964 - 1967 Mustangs.  
**Heater Hose Clamp**  
60-67 ..... C3AZ-18572-A

**WE PROUDLY FEATURE AUTHENTIC MUSTANG REPRODUCTIONS FROM SCOTT DRAKE ENTERPRISES!**



### INTAKE MANIFOLD BOLT KIT



Concours correct with the exact head markings. Not an off the shelf generic copy. These are 100% correct or your money back!

#### Intake Manifold Bolt Kit

64-67	260, 289	IMB-C40E-478
67	GT500	IMB-C3AE-493
67-68	390, 428	IMB-B8AE-475
68	GT500	IMB-S8ME-477
68-69	289, 302	IMB-C80E-479
69	351 W	IMB-C90E-1131
69	Boss 302	IMB-C9ZE-1306
69-70	Boss 429	IMB-C9AE-1376
69-70	390, 428	IMB-C90E-476
70	Boss 302	IMB-D0ZE-1320
70-73	351 2V	IMB-D00E-1313
70-73	302	IMB-D00E-1123
70-73	351 Cleveland 4V	IMB-D00E-1321

### STARTER BOLT



These are the real thing. Not just a generic bolt. Yes, judges do check these details. 2 piece set. Special 1/2" head.

#### Starter Bolt

65-73	Special 1/2" head	C8ZL-1410
-------	-------------------	-----------

### UNDER HOOD DETAILING KIT



PICTURE IS FOR REFERENCE ONLY  
Exact contents will vary based on application

These Under Hood Detail Kits vary from year to year but most Kits include mounting hardware for: Hood Hinges, Hood, Outer

Shock Tower Bolts and Nuts, Top Fender Bolts, Hood Latch Support, Grille, Cowl Braces, Upper Shock Tower Cap Bolts and Nuts, Top Shock Mounting Bolts, Fan Shroud, Starter Solenoid, Voltage Regulator, Horns, Heater Blower Motor, Battery Hold Down (Bracket not included), Washer Nozzles, Washer Bracket, Wire Harness Ties and Clips.

#### Under Hood Detailing Kit

65	C5ZB-UH
66	C6ZB-UH
67	C7ZB-UH
68	C8ZB-UH
69	C9ZB-UH
70	D0ZB-UH
71	D1ZB-UH
73	D3ZB-UH

### VALVE COVER BOLT

These valve cover bolts come in either allen or hex head style.

#### Valve Cover Bolt



64-73: Allen head, black  
VCB-AB



64-73: Allen head, stainless steel  
VCB-AS



64-73: Hex head, zinc plated  
VCB-HC

### VALVE COVER BOLT SET



A great addition to a concours engine. These exact copies feature details of the originals. All head markings are correct.

Not an off the shelf generic copy.

#### Valve Cover Bolt Set

64-73	170, 200, 250 6 cylinder	VCB-CODE-480
64-73	Small block, Boss 302 with stamped steel covers	VCB-C20E-481
65-68	Cobra valve covers "RBW"	VCB-S1ME-1438
69-73	Plain head with washers	VCB-S9ME-1619
70-73	351 Cleveland	VCB-D00E-482
67-70	390, 427, 428	VCB-B8AE-339
70-71	Boss 302, 351 with aluminum covers and Boss 351 "E" logo	VCB-D0ZE-483
67-68	428 Shelby "RBW" logo	VCB-S7ME-310
69-70	GT-350	VCB-S9MB-1619
64-73	Hex head, cadmium plated	VCB-HC-5

### VOLTAGE REGULATOR MOUNTING KIT



3 piece kit. Correct screws to mount voltage regulator.

#### Voltage Regulator Mounting Kit

65-67	VRM-C5ZL-404
68	VRM-C8ZL-406

### VOLTAGE REGULATOR SCREW CAP



Plastic caps used to cover sharp points on screws that mount voltage regulator.

#### Voltage Regulator Screw Cap

64-66	C5ZZ-10316-S
-------	--------------

### WINDAGE TRAY BOLT KIT



Add a windage tray. This kit has eight bolts, four that hold the tray and four that replace main cap bolts.

#### Windage Tray Bolt Kit

65-73	Eight bolt kit	C9ZE-3256
-------	----------------	-----------

### WIRING LOOM TIES



These wire loom ties are found through out the engine compartment. Black nylon. Complete kits available. See electrical

section.

#### Wiring Loom Ties

64-73	376914-S
-------	----------

## EXTERIOR HARDWARE

### BACK UP LIGHT SPACER



Stamped steel and zinc plated. Mounts on backup lamp housing stud between rear valence and nut. 4 piece set. This unique

spacer is also used on 65-66 Fastback Louvers.

#### Back Up Light Spacer

64-68	359972-58
-------	-----------

### BILLET GRILLE EMBLEM MOUNTING CLIPS



These steel clips are specially designed to mount the C5ZZ-16229-B Running Horse Fender Emblem to a billet grille.

#### Billet Grille Emblem Mounting Clips

64-11	C5ZZ-16229-BGMC
-------	-----------------

**COWL-HOOD GROUNDING STRAP**



This piece is an exact reproduction. Brass contact strap with correct mounting screw.

**Cowl-Hood Grounding Strap**  
67-68 .....C5AA-18870-A

**DOOR GRILLE MOUNTING KIT**



This kit is required to mount our dlx door grilles. 24 piece kit includes black screws and unique mounts.

**Door Grille Mounting Kit**  
67-68 .....C7ZN-3301

**DOOR HINGE MOUNT KIT**



OE looking bolts with built in washers. Black oxide finish.

**Door Hinge Mount Kit**  
64-65 6 bolts, black, 3/8" threads 379043-SMK  
66-68 6 bolts, black, 5/16" threads .. 380575-S2

**DOOR LATCH SCREW**



Correct screws with special star washers. Set of six.

**Door Latch Screw**  
64-70 Set of 6 .....356782-S

**EMBLEM BARREL CLIP**



A must when re-mounting emblems. Correct in every way.

**Emblem Barrel Clip**  
64-73 Pin diameter range .184-.190 (large) .... 375480-S  
64-73 Pin range diameter .120-.130 (medium) 375890-S  
64-73 Pin range diameter .062-.072 (small) .... 378362-S

**EXTERIOR TRIM SCREW KIT**



Exterior screw kits include outside mirror, parking lamp lens, back up lamp lens, headlamp door and tail lamp screws.

**Exterior Trim Screw Kit**  
64-66 ..... ITS-65-EXT  
67-68 ..... ITS-67-EXT

**AFTERMARKET FENDER AND BODY BOLT**

Not concourse correct head pattern, but very good looking. All 5/16-18 x 7/8 long.  
**Fender And Body Bolt, Aftermarket**



64-73: Polished stainless steel, 5/16-18x7/8 long 378178-SS



66-68: Black, 5/16-18x7/8 long 378178-DB



66-68: Bright cadmium finish, 5/16-18x7/8 long 378178-DC

**CONCOURS FENDER AND BODY BOLT**

Authentic copies of the original. These are the most commonly used bolts on all Fords, virtually used throughout car but most visible on fenders.

**Fender And Body Bolt, Concourse**



65-67: HTS, External star, black, 5/16-18x15/16 long 7/8 OD 378156-S2-HTS



65-67: HTS with rings, external star, black, 5/16-18x15/16 long 7/8 OD 378156-S2-HTS/R



65-67: SEMS, external star, black, 5/16-18x15/16 long, 7/8 OD 378156-S2-S



65-67: ANCHOR, external star washer, black, 5/16-18x1& 1/16 long 7/8 OD 378178-S2-ANCH



66-67: DITTO, conical toothed washer, black, 5/16-18x1 inch long 13/16 OD 378178-S2-DITTO

**Fender And Body Bolt, Concourse**



66-67: SEMS, conical toothed washer, black, 5/16-18x1 inch long 13/16 OD 378178-S2E



66-67: SEMS, conical toothed washer, black, 5/16-18x1 1/4 long, 13/16 OD 378242-S2-SEMS



67-73: FLAG, conical washer, yellow gold, 1/4-20x7/8 long, 3/4 OD 57030-S236



67-73: N, conical washer, 5/16-18x7/8 long, 7/8 OD B-11598



68: Anchor disc



68: RBW, conical disc washer, black, 5/16-18x1 inch long 13/16 OD 378178-S2



68: S, conical toothed, silver, 5/16-18x7/8 long, 7/8 OD 378178-S7



68-73: FLAG, conical washer, black, 5/16-18x7/8 long, 7/8 OD 57039-S2



69-70: FLAG, conical washer, yellow gold, 5/16-18x7/8 long, 7/8 OD 57039-S36



69-70: FLAG, conical washer, soft silver, 5/16-18x7/8 long, 7/8 OD 57039-S7

**SMALL FENDER AND VALANCE BOLT**



This bolt has a 1/4-20 thread and is 3/4 inch long from the head down. It is used several places throughout the car, but primarily

in the front sheet metal such as the valance, headlamp assembly to fenders, etc.

**Fender And Valance Bolt, Small**

64-73 ..... 43263-S BOLT

Hardware

**WE PROUDLY FEATURE AUTHENTIC MUSTANG REPRODUCTIONS FROM SCOTT DRAKE ENTERPRISES!**



95



### FENDER TO COWL BOLT

Made of heavy gauge spring steel. Includes bolt and retainer.



Fender To Cowl Bolt  
65-66 ..... 378685-S2

### FENDER TO COWL NUT SET

Pair of captive nuts on stamped steel winged plates. Snaps into rocker. Very special nut hard to find.



Fender To Cowl Nut Set  
64-70 ..... 359613-SK

### FRONT VALANCE MOUNTING KIT

This kit is used to mount front valance to fenders, stone deflector and lower front cross member.



Front Valance Mounting Kit  
64-68 ..... 43263-SMK

### GRILLE MOUNTING CLIP

A must for holding the grille moulding in place. Made from tough ABS plastic. Will not fit 71-72.



Grille Mounting Clip  
71-72 ..... D1ZZ-8251-A  
73 ..... D3ZZ-8251-A

### GRILLE MOUNTING KIT

These are not just generic pieces. OE correct. Show quality.



Grille Mounting Kit  
65 12 piece kit ..... C5ZB-8200-MK  
66 16 piece kit ..... C6ZB-8200-MK  
67 10 piece kit ..... C7ZB-8200-MK  
68 10 piece kit ..... C8ZB-8200-MK  
69-70 7 piece kit ..... C9ZB-8200-MK

### HEADLIGHT ADJUSTING KIT

Includes threaded adjusting stud and nylon insert. Nylon insert is slightly larger than O.E.M. and requires minimal filing



for proper fit.  
Headlight Adjusting Kit  
64-66 ..... C3MY-13181/032K

### HEADLIGHT ADJUSTING NUT

These are the nuts that are used to adjust the headlamp beam trajectory. It is also available in the headlamp adjusting



kit, Part # C5ZZ-13008-MK.  
Headlight Adjusting Nut  
64-66 ..... C3MY-13181-A

### HEADLIGHT ASSEMBLY HARDWARE KIT

A complete kit to mount a headlight assembly to the fender, everything you need. Sold each, it takes two per car.  
Headlight Assembly Hardware Kit



64-66  
C5Z-13008-MK

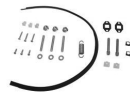

67-68  
C7Z-13008-MK



69: 1 side (2 kits required per vehicle)  
C8AZ-13118/9-MK

### HEADLIGHT DOOR RETAINER CLIP KIT

#### KIT

Mounts on headlamp assembly, headlamp door screws attach to this clip. 8 piece set.



Headlight Door Retainer Clip Kit  
64-66 ..... 357033-SK

### HEADLIGHT DOOR SCREW KIT

Special Phillips Head screw, exact copy. Made from rust proof stainless steel. 8 piece set.



Headlight Door Screw Kit  
64-66 ..... 378852-SK

### HOOD HINGE MOUNTING KIT



Hood Hinge Mounting Kit  
64-70 ..... 359662-SMK

### J NUT FASTENER



Correct fasteners that are used under fender bolts. Fender bolts thread into J nuts. Also used on many other applications

throughout the Mustang.  
J Nut Fastener  
64-73 5/16x18 ..... 379831-S  
64-73 1/4x20 ..... 43263-SNUT

### LICENSE PLATE MOUNTING KIT

Kit includes 4 screws, 2 metal nuts, 2 self-threading plastic nuts and 2 anti-rattle bumper.



License Plate Mounting Kit  
64-73 ..... 380707-SK

### LICENSE PLATE NUT FASTENER

Self threading white plastic. Used in front and rear valances. Perfect match.



License Plate Nut Fastener  
64-73 ..... 380707-S

### MASTER BODY KIT

All concours correct. These new kits include all sheet metal attaching hardware necessary to properly reassemble



a Mustang body. Most kits include Battery tray, bumper guard-front, bumper guard rear, bumper guard mount brackets, bumper guard pads, cowl braces, door hinges, door latches, fenders, fender pillar brackets, fender extensions, fender splash shields, fender splash shield brackets, floorboard hole covers, grille, grille supports, headlamp doors, hood and hood hinges, hood bumper, hood latch and catch, hood latch support, quarter panel extensions, stone deflector, suspension bumper brackets-front, trunk latch and striker, trunk lid and hinges, valance front and valance

rear. Also includes assembly instructions.

**Master Body Kit**

64-65	.....	MBK-C5ZB-MASTER	
66	.....	MBK-C6ZB-MASTER	
67	.....	MBK-C7ZB-MASTER	
67	Shelby	.....	MBK-S7MB-MASTER
68	.....	MBK-C8ZB-MASTER	
68	Shelby	.....	MBK-S8MB-MASTER
69	.....	MBK-C9ZB-MASTER	
69-70	Shelby	.....	MBK-S9MB-MASTER
70	.....	MBK-D0ZB-MASTER	
71	.....	MBK-D1ZB-MASTER	
72	.....	MBK-D2ZB-MASTER	
73	.....	MBK-D3ZB-MASTER	

**MASTER CHASSIS KIT**



These kits are huge! Once again these are not generic off the shelf typical bolts. Each one is an exact copy from the

original equipment manufacturer. A typical kit would include the following: Accelerator bellcrank, rear axle retainers/rear brake plates, front brake plates, brake booster, brake cables, brake calipers, brake drums, brake hoses, spring perches, control arms, front crossmember, axle housing, differential carrier, driveshaft, engine mounts, gas cap, gas tank, filler neck, idler arm, leaf spring front eye, master cylinder, parking brake control, pitman arm, proportioning valve, rag joint, front shocks, shock brackets, steering gear, steering linkage, strut rods, sway bar insulator brackets, transmission crossmember, transmission insulator and wheel cylinders. Remember only fasteners are included.

**Master Chassis Kit**

65	289 High Performance, disc	.....	MCK-C5ZS-DCHP
65	260-289, disc	.....	MCK-C5ZS-DCSB
65	260-289, drum	.....	MCK-C5ZS-DRSB
65	170, 200, drum	.....	MCK-C5ZS-DRSX
66	289 High Performance, disc	.....	MCK-C6ZS-DCSB
66	289, drum	.....	MCK-C6ZS-DRSB
66	170, 200, drum	.....	MCK-C6ZS-DRSX
67	390, 428, disc	.....	MCK-C7ZS-DCBB
67	289 High performance, disc	.....	MCK-C7ZS-DCSB
67	289, drum	.....	MCK-C7ZS-DRSB
67	200, drum	.....	MCK-C7ZS-DRSX
68	390, 428, disc	.....	MCK-C8ZS-DCBB
68	289, 302, disc	.....	MCK-C8ZS-DCSB
68	289, 302, drum	.....	MCK-C8ZS-DRSB
68	200, drum	.....	MCK-C8ZS-DRSX
69	390, 428, disc	.....	MCK-C9ZS-DCBB
69	302, 351, disc	.....	MCK-C9ZS-DCSB
69	302, 351, drum	.....	MCK-C9ZS-DRSB
69	200, drum	.....	MCK-C9ZS-DRSX

**Master Chassis Kit**

69	250, drum	.....	MCK-C9ZS-DRSX
69	428, disc	.....	MCK-C9ZS-HDBB
69	Boss 429, disc	.....	MCK-C9ZS-HDBG
69	Boss 302, Boss 351, disc	.....	MCK-C9ZS-HDSB
70	Boss 429, disc	.....	MCK-D0ZD-HDBG
70	302, 351, disc	.....	MCK-D0ZS-DCSB
70	302, 351, drum	.....	MCK-D0ZS-DRSB
70	200, drum	.....	MCK-D0ZS-DRSS
70	250, drum	.....	MCK-D0ZS-DRSX
70	428, disc	.....	MCK-D0ZS-HDBB
70	Boss 302, Boss 351, disc	.....	MCK-D0ZS-HDSB
71	429, disc	.....	MCK-D1ZS-DCBB
71-73	302, 351, disc	.....	MCK-D1ZS-DCSB
71-73	250, disc	.....	MCK-D1ZS-DCSX
71-73	302, 351, drum	.....	MCK-D1ZS-DRSB
71-73	250, drum	.....	MCK-D1ZS-DRSX

**MOLDING HARDWARE**



We offer these complete hardware kits for your customer's convenience. Kits include high strength backing plates and all

necessary screws, clips, or rivets.

**Molding Hardware**

64-66	Left or right	.....	C5ZZ-6510182-K
67-68	Left hand	.....	C7ZZ-6510182-KL
67-68	Right hand	.....	C7ZZ-6510182-KR

**BULK REAR VALANCE FASTENER**



This is the correct one, not an after market product off the shelf, but made from our own tooling. Plated to prevent rust. Kit

includes nuts.

**Rear Valance Fastener, Bulk**

64-73	.....	372719-S100-B
-------	-------	---------------

**REAR VALANCE MOUNTING KIT**



Rear Valance Hardware kit contains 2 clips and 2 nuts.

**Rear Valance Mounting Kit**

64-70	.....	372719-S100
-------	-------	-------------

**REAR VALANCE MOUNTING SET**

Set contains 11 screws.



**Rear Valance Mounting Set**

64-68	.....	376525-SK
-------	-------	-----------

**SERRATED FLANGE NUT**

A 5/16x18 serrated flange nut that is used in several locations throughout.



**Serrated Flange Nut**

64-73	.....	34392-S
-------	-------	---------

**STONE DEFLECTOR MOUNTING KIT**



**Stone Deflector Mounting Kit**

64-66	10 piece kit	.....	SDM-C5ZB-119
67-68	10 piece kit	.....	SDM-C7ZB-208

**TAIL LIGHT HOUSING MOUNTING NUT**

These hard to find nuts are concours correct and feature high-quality zinc plating. 64-66 pictured. 67-68 feature external lock



washers like originals.

**Tail Light Housing Mounting Nut**

64-66	Set of 8	.....	359606-S8
67-68	Set of 12	.....	377523-S

**TOP FENDER HARDWARE KIT**



Our top fender hardware kit is a convenient way to get the right hardware in one package. 24 pieces. 12 black bolts

and 12 J clips. Kit uses 378178-DB bolts.

**Top Fender Hardware Kit**

64-68	.....	378178-TFM
-------	-------	------------

Hardware

**WE PROUDLY FEATURE AUTHENTIC MUSTANG REPRODUCTIONS FROM SCOTT DRAKE ENTERPRISES!**



## FUEL SYSTEM HARDWARE

### FUEL PUMP MOUNTING KIT



Concours correct fasteners, mounts fuel pump to engine.

#### Fuel Pump Mounting Kit

64-73 6 Cylinder, 170,200,250 . FPM-CODE-518  
64-73 Small Block 260,289,302,351W .....  
FPM-C50E-519

## INTERIOR HARDWARE

### ARM REST BASE TO DOOR PANEL SCREW



Cadmium plated truss head screws. Just like original. 4 Piece Set.

#### Arm Rest Base To Door Panel Screw

64-66 .....377905-S

### ARM REST PAD TO BASE SCREW KIT



Attaches pad to chrome base. Black oxide. 4 piece set.

#### Arm Rest Pad To Base Screw Kit

64-66 .....32930-SK

### ARM REST RETAINING CLIPS



Very unique clips, exact copies of the originals.

#### Arm Rest Retaining Clips

64-66 .....BA-7024146-A  
67-68 .....C7AB-6224146-C

### DASH PANEL NUT



These are exact reproductions. Gold zinc plated. Almost too nice to hide behind the dash. Sold in sets of 8 pieces.

#### Dash Panel Nut

67-68 ..... 376642-S36

### DOOR SILL PLATE SCREW



Chrome plated oval head screw to hold sill plates in position.

#### Door Sill Plate Screw

64-68 Set of 18 .....376290-SK  
64-70 Bulk .....376290-S

## FIREWALL INSULATION FASTENERS



#### Firewall Insulation Fasteners

64-73 Plastic replacement .....357036-S100-P  
68-73 Rubber .....C8Z-6501691

### HORN RING RETAINER SCREW



Mounts plastic retainer to horn ring assembly.

#### Horn Ring Retainer Screw

64-68 .....51763-S

### INSIDE DOOR HANDLE AND WINDOW CRANK SCREW

We have these exact reproductions made especially for us. You want to use right parts, not something close. Chrome plated just like the originals. Sold in sets of 4.

#### Inside Door Handle And Window Crank Screw



65-66: Set of 4  
379259-S



67-70: Set of 4  
381571-S

### INTERIOR FASTENER KIT



Now available from Scott Drake, Interior Assembly Fastener Kits! These comprehensive kits include almost every fastener needed for your vehicle's interior. Each application within the kit is separately packaged so you know exactly where it goes,

and most oval head sheet metal screws in our kits are stainless with chrome, black, or zinc finish.

Interior Fastener Kit

65-66	Fastback, standard	.....	KIT-65Z-63A
65-66	Fastback, deluxe	.....	KIT-65Z-63B
65-66	Coupe, standard	.....	KIT-65Z-65A
65-66	Coupe, deluxe	.....	KIT-65Z-65B
65-66	Convertible, standard	.....	KIT-65Z-76A
65-66	Convertible, deluxe	.....	KIT-65Z-76B
67	Fastback, standard	.....	KIT-67Z-63A
67	Fastback, deluxe	.....	KIT-67Z-63B
67	Coupe, standard	.....	KIT-67Z-65A
67	Coupe, deluxe	.....	KIT-67Z-65B
67	Convertible, Standard	.....	KIT-67Z-76A
67	Convertible, deluxe	.....	KIT-67Z-76B
68	Fastback	.....	KIT-68Z-63
68	Coupe	.....	KIT-68Z-65
68	Convertible	.....	KIT-68Z-76
69	Fastback	.....	KIT-69Z-63
69	Coupe	.....	KIT-69Z-65
69	Convertible	.....	KIT-69Z-76
70	Fastback	.....	KIT-70Z-63D
70	Coupe	.....	KIT-70Z-65D
70	Convertible	.....	KIT-70Z-76D
71-73	Fastback, Deluxe	.....	KIT-71Z-63L

### INTERIOR TRIM SCREW KIT



Convenient kits that are packaged for impulse sales. Skin packaging includes screw descriptions on front of card for extra

convenience. Kit includes the basic screws used on most interior restorations. All screws are brilliantly chromed plated. This kit contains pillar trim, kick panel, coat hooks, visor bracket, rear view mirror, door sill plates and windshield trim screws.

#### Interior Trim Screw Kit

64-66	Coupe	.....	ITS-65-CP
64-66	Convertible	.....	ITS-65-CV
64-66	Deluxe	.....	ITS-65-PO
65-66	Fastback	.....	ITS-65-FB
67-68	Coupe	.....	ITS-67-CP
67-68	Convertible	.....	ITS-67-CV
67-68	Fastback	.....	ITS-67-FB

### KICK PANEL SCREW



Chrome plated broad head screws to secure plastic kick panels in position. Kit does one car. Some cars only use 4 per car.

#### Kick Panel Screw

64-68 Set of 6 .....350075-SK

**SEAT RETAINING NUT**



Another exact reproduction by Scott Drake. Painted to prevent rust. Color is dark red.

Seat Retaining Nut  
64-70 Set of 4 ..... 378643-SK

**SEAT TRACK BOLT**



Seat Track Bolt  
64-70 Set of 4 ..... 379874-SK

**WINDOW GUIDE**



Prevent the glass from rattling in the door. White ABS plastic. 16 required for each car.

Window Guide  
69-70 ..... C9Z-6521496

**SHIFTER, CLUTCH & DIFFERENTIAL HARDWARE**

**PRESSURE PLATE BOLT SET**



These are the real thing, not just a generic copy.

Pressure Plate Bolt Set  
65-72 Set of 6 ..... B7AT-3263

**REAR END HOUSING NUT AND WASHER KIT**



Original style, cadmium plated self-locking nuts. Kit includes 10 nuts and 10 washers.

Rear End Housing Nut And Washer Kit  
64-73 20 piece kit, silver cad. nuts ..... MDK001  
68-73 20 piece kit, red nuts ..... MDK002

**SHIFT COVER SCREW**

Correct color and size.



Shift Cover Screw  
64-68 Automatic ..... 52720-SK

**SHIFTER SPRING**

This is the tension spring that goes behind the trunnion at the base of the manual shifter. See transmission section for shifter rebuild kits.



65-68: 3 speed  
C2AZ-7208-C



65-68: 4 speed  
C2AZ-7208-D

**SHIFTER TRUNNION**

These are the metal cups that are located at the end of the shifter to firm up a loose, wobbly shifter. Also sold in kits, see "Transmission" section.

Shifter Trunnion



64-68: 4 speed  
C2AZ-7B125-A



64-68: 3 speed  
C2AZ-7B125-B

**SUSPENSION HARDWARE**

**SHOCK TOWER BOLT**



Special bolts that slip into shock tower to retain shock tower cap.

Shock Tower Bolt  
64-66 Set of 6, silver zinc ..... 355471-SK  
67-73 Set of 6, black zinc ..... 378353-SK

**SHOCK TOWER NUT**



Special hex nut with external star washer. Zinc plated.

Shock Tower Nut  
64-66 Set of 6 Nuts ..... 33923-SK

**Shock Tower Nut**

64-66 Set of 4 Top Mount Bolts ..... 373406-SK

**SHOCK TOWER NUT**



Now available from Scott Drake, these 1967-73 Mustang Shock Tower Nuts are zinc plated. The flanged nuts are used

to hold the Shock Tower Caps in place. Six piece set.

Shock Tower Nut  
67-73 Set of 6 ..... 33791-SK

**HEATING & AC**

**AIR CONDITIONING**

**AC & HEATER INTERIOR (ELECT CTRLS AND DASH BEZELS)**



Inside package air conditioning/heater assembly. Features electronic control package and original dash bezels.

Everything needed for the interior.  
AC & Heater Interior (Elect Ctrls and Dash Bezels)  
64-66 ..... IP-1165M  
67 ..... IP-1267M  
68 ..... IP-1268M

**AC & HEATER INTERIOR PACKAGE (ELECTRONIC CONTROLS)**



Inside package air conditioning/heater assembly. Features electronic control package. Everything needed for the interior

of the car except factory AC vents. Made for you to re-use your original dash vents. Passenger and Driver side vents also available from Scott Drake.  
AC & Heater Interior Package (Electronic Controls)  
67 ..... IP-1367M  
68 ..... IP-1368M

**HURRICANE AC & HEATER KIT (ELECTRONIC CONTROLS)**



Complete Heater A/C Conversion System with upgraded Electronic controls. Must be used in conjunction with your

original A/C Dash Vents and Control Panel.

Heater & AC

**WE PROUDLY FEATURE AUTHENTIC MUSTANG REPRODUCTIONS FROM SCOTT DRAKE ENTERPRISES!**



Designed to be used we 134a refrigerant. R12 Kit can be special ordered as well as a kit with Compressor bracket on opposite side than original. Additional charges may apply.

- AC & Heater Kit (Electronic Controls), Hurricane**
- 67 Fits non-AC w/ original 289 w/out power steering .....CAP-1367M-289
  - 67 Fits non-AC w/ original 289 w/ factory power steering .....CAP-1367M-289P
  - 67 Fits non-AC w/ original 390 w/ factory power steering .....CAP-1367M-390
  - 68 Fits non-AC w/ original 289-302 w/out power steering .....CAP-1368M-289
  - 68 Fits non-AC w/ original 289-302 w/ factory power steering .....CAP-1368M-289P
  - 68 Fits non-AC w/ original 390 .....CAP-1368M-390

**HURRICANE AC & HEATER KIT (ELECTRONIC CONTROLS AND ORIGINAL DASH BEZELS)**



Complete Heater A/C Conversion System with upgraded Electronic controls. Includes Factory A/C Control Panel & RH

Dash Vents. Designed to be used we 134a refrigerant. R12 Kit can be special ordered as well as a kit with Compressor bracket on opposite side than original. Additional charges may apply.

- AC & Heater Kit (Electronic Ctrl's and Dash Bezels), Hurricane**
- 65-66 Fits 289 w/out generator .....CAP-1165M-289
  - 65-66 Fits 200/6-cyl w/out generator .....CAP-1165M-6
  - 67 Fits non-AC w/ original 289 w/out power steering .....CAP-1267M-289
  - 67 Fits non-AC w/ original 289 w/ factory power steering .....CAP-1267M-289P
  - 67 Fits non-AC w/ original 390 w/ factory power steering .....CAP-1267M-390
  - 68 Fits non-AC w/ original 289-302 w/out power steering .....CAP-1268M-289
  - 68 Fits non-AC w/ original 289-302 w/ factory power steering .....CAP-1268M-289P
  - 68 Fits non-AC w/ original 390 .....CAP-1268M-390

Heater & AC

**HURRICANE AC & HEATER KIT (MANUAL CABLE CONTROLS)**



The Hurricane is a complete system that

replaces your original heater box and adds a modern, high efficiency A/C and heater/ defroster in its place. It is a custom fit that utilizes all the factory firewall holes. No extra holes are needed. A new 3 speed switch neatly intergrates into the factory heater control plate. Compact design allows easy installation and retains the glove box.

- AC & Heater Kit (Manual Cable Controls), Hurricane**
- 65-66 260, 289 with alternator .....CAP-1065M-289
  - 67-68 289 Mustang and Cougar without power steering .....CAP-1067M-289
  - 67-68 289 Mustang and Cougar with power steering .....CAP-1067M-289P
  - 67-68 6 cylinder .....CAP-1067M-6
  - 69-70 302, 351W Mustang and Cougar .....CAP-1069M-302
  - 69-70 351 Cleveland, Mustang and Cougar .....CAP-1069M-351C
  - 69-70 390, 428 Mustang and Cougar .....CAP-1069M-390

**AC KIT**



This complete package includes the underdash unit, drain tube, mounting brackets, compressor, all necessary hoses,

receiver /dryer and condensor. This kit performs better than the original ever did and requires less horsepower to operate.

- AC Kit**
- 64-66 OE style for 6 cylinder .....CAP-365M-6
  - 64-66 OE style for V8 .....CAP-365M-289
  - 67-68 289 with power steering .....CAP-367M-289P
  - 69-70 1300 series for Mustang and Cougar .....CAP-1369-390

**AC VENT**

Replacement air conditioning vents for the instrument panel.

**AC Vent**



67: Left hand side, includes knobs  
C7Z-19C696-A

**AC Vent**



67-68: Right hand side  
C7Z-19893-A

68: Left hand side, includes knobs  
C8Z-19C696-AEA

**AC VENT DUCT HOSE ADAPTERS**

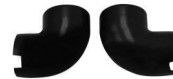

- AC Vent Duct Hose Adapters**
- 67-68 .....C7Z-19C692

**AC VENT HOSES**

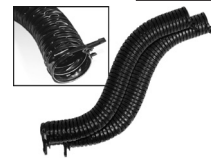

- AC Vent Hoses**
- 67-68 with cam-locks .....C7Z-18556-A/C

**AIR CONDITIONER BLOWER SWITCH**



Air conditioning blower switch (five terminal) for 1966 Mustang.

- Air Conditioner Blower Switch**
- 66 5 terminal .....C6Z-19986

**AIR CONDITIONER DRAIN HOSE**



Molded rubber flex hose, just like original. Now by Drake!

- Air Conditioner Drain Hose**
- 65-68 .....C8TZ-19858-A

**AIR CONDITIONER FEED HARNESS**



Plugs into main A/C unit under dash, connects into back of ignition switch then, runs through firewall to compressor switch.

- Air Conditioner Feed Harness**
- 64-66 .....C5Z-19800-ACF

**Air Conditioner Feed Harness**  
67 .....C7ZZ-19800-ACF

**AIR CONDITIONER HOSE STRAPS**

Holds A/C hose from cowl braces.



**Air conditioner Hose Straps**  
67-70 .....C7ZA-430

**AIR CONDITIONER REGISTER**

Our high quality registers feature a great fit to provide an exact replacement for the originals. Injection molded for a precision fit and long life.

**Air Conditioner Register**



64-65: Front, chrome  
C3AZ-19A671-A



64-65: Side, black  
C5ZZ-19A671



66: Front, chrome  
C6AZ-19A671-A



66: Side, black  
C6ZZ-19A671

**AIR CONDITIONER REGISTER CLIP**

These clips are needed for correct installation of registers. Sold in a set of 8 for your convenience.



**Air Conditioner Register Clip**  
64-66 Set of 8 .....C3AZ-19A683-K

**AIR CONDITIONER THERMOSTAT**



Made by original supplier. Stops evaporator coil from freezing up.

**Air Conditioner Thermostat**  
64-66 .....C5ZZ-19A671-A  
67-73 .....C7ZZ-19A671

**AIR CONDITIONER VACUUM MOTOR**



Works for most applications. Modification to bracket may be required. Replacement style.

**Air Conditioner Vacuum Motor**  
67-73 .....C7AZ-18A318-AR

**AIR CONDITIONER VACUUM SWITCH**



Mounts on the main air chamber and opens and closes the air vent. Made of nylon with a steel and brass plunger.

**Air Conditioner Vacuum Switch**  
67-70 .....C7ZZ-18C311

**AIR VENT ASSEMBLY**



Complete air vent including the cable, knob, and bracket. Very well built.

**Air Vent Assembly**  
65-66 .....C5ZZ-6501934-A  
67-68 .....C7ZZ-6501934-A  
69-70 Left hand .....C9ZZ-6501934-L  
69-70 Right hand .....C9ZZ-6501934-R

**ALUMINUM LIQUID LINE**



Connect to 90 degree liquid fitting at bottom of radiator core support and climbs shock tower to connect to sight glass

hose.  
**Aluminum Liquid Line**  
64-66 .....C5ZZ-19837-B

**COIN TRAY**

Exact reproduction with polished aluminum trim and textured vinyl insert.



**Coin Tray**  
64-65 .....C5ZZ-19869

**COMPRESSOR ADJUSTER**



**Compressor Adjuster**  
65-67 6cylinder .....C5ZZ-7105-A

**COMPRESSOR CLUTCH BRUSHES**

These are exact reproductions made from the original tooling.



**Compressor Clutch Brushes**  
64-70 .....C5ZZ-2979

**COMPRESSOR CONVERSION KIT**



Update your factory AC system with this compressor conversion kit. Sanden compressor and custom hoses provide

a neat, clean underhood appearance. Kits include mounting brackets and hardware. Increase engine performance, gas mileage while eliminating vibration and belt noise.

**Compressor Conversion Kit**

64-65 V8, R134a	50-3065
64-65 289, R12	50-3065R12
64-65 6 cylinder, R134a	50-3165
64-65 6 cylinder, R12	50-3165R12
66 289, R134a	50-3066
66 6 cylinder R134a	50-3166
66 6 cylinder, R12	50-3166R12
67 289, R134a	50-3067
67 289, R12	50-3067R12
67 6 cylinder, R134a	50-3167
67-68 67-390, 68-289, 390, R12	50-3068R12
68 V8, R134a	50-3068
68 6 cylinder, R12	50-3168R12
69-70 302, R134a	50-3069
69-70 302, R12	50-3069R12
69-70 6 cylinder, R134a	50-3169
69-70 6 cylinder, R12	50-3169R12
71-73 6 cylinder, R134a	50-3171
71-73 6 cylinder, R12	50-3171R12

Heater & AC

**WE PROUDLY FEATURE AUTHENTIC MUSTANG REPRODUCTIONS FROM SCOTT DRAKE ENTERPRISES!**



## UNDERHOOD PERFORMANCE / COMPRESSOR CONVERSION KIT



These kits include our popular Sanden style compressor & bracket, Super-Kool condenser with factory style drier, new AC hoses

and compressor safety switch. Maximize AC performance, increase engine horsepower, and improve gas mileage!

### Compressor Conversion Kit, Underhood Performance /

65	V8	50-0012
65	200	50-0017
66	V8	50-0013
66	200	50-0014
66	200	50-0015
67	SB	50-0016
68	SB & BB	50-0018
68	200	50-0019
69-70	V8	50-0020
69-70	6-Cylinder	50-0021

## COMPRESSOR COVER



This cover plate bolts to the top of the original A/C compressor to dress up the

engine compartment. A nice match to our Aluminum Finned Valve Covers. Features Cobra or Mustang logo or plain. Available in satin or polished. Mounting hardware included.

### Compressor Cover



64-73: Cobra, satin<sup>s</sup>  
CSZ-19703-CS



64-73: Mustang, polished\*  
CSZ-19703-MP



64-73: Mustang, satin\*  
CSZ-19703-MS



64-73: Plain, polished  
CSZ-19703-PP



64-73: Plain, satin  
CSZ-19703-PS

## SANDEN COMPRESSOR MOUNT KIT



This is the kit you will need to install a Sanden compressor on your original York compressor bracket.

### Compressor Mount Kit, Sanden

64-73 ..... CSZ-2882-SCMK

## CONDENSER



Exact reproduction of the original aluminum serpentine condenser. The original material and construction design is absolutely

mandatory for proper system function and to prevent engine over-heating.

### Condenser

64-66	.....	CSZ-19712-A
67-68	.....	C7Z-19712-A
69-70	.....	C9Z-19712-A
71-73	.....	D1Z-19712-A

## HIGH PERFORMANCE CONDENSER DRYER KIT

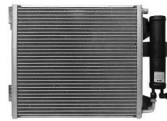

Includes OEM style receiver drier and mounting bracket for easy installation into original factory locations. New design

technology incorporates a high heat-rejection, low refrigerant and air pressure drop as compared to the original condensers.

### Condenser Dryer Kit, High Performance

64-66	.....	CSZ-19712-HPK
67-68	.....	C7Z-19712-HPK
69-70	.....	C9Z-19712-HPK

## CONDENSER HOSE GROMMET

These grommets protect the condenser hoses as they pass through the radiator support on earlier Mustangs. Sold as a set of two.

### Condenser Hose Grommet



64-66  
378264S/379075S



67-68  
C7Z-19819

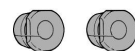

69-70  
C9Z-19819

## CONDENSER MOUNTING BRACKET



Painted black to stop corrosion. Four special brackets used to mount condenser.

### Condenser Mounting Bracket

64-66 ..... CSZ-19B594-R

## DASH SPACER BAR



Fills gap between dash and A/C unit. Painted black. Helps hold interior air conditioning unit to dash.

### Dash Spacer Bar

64-65	.....	CSZ-19C604
66	.....	C6Z-19C604

## DISCHARGE HOSE



Concours high pressure hoses with correct authentic looking fittings. Made in the U.S.A. Hoses need replacing

when they show dry rot and cracking. Check crimped sleeves to hose for looseness by twisting fitting.

### Discharge Hose

64-66	6 cylinder, concours	.....	CSZ-19972-6
64-66	8 cylinder, concours	.....	CSZ-19972-8
67-68	6 cylinder, concours	.....	C7Z-19972-6
67-68	8 cylinder, concours	.....	C7Z-19972-8
69-70	8 cylinder, concours	.....	C9Z-19972-8
71-73	6 cylinder, concours	.....	D1Z-19972-6
71-73	8 cylinder, concours	.....	D1Z-19972-8

## FILTER DRYER



Exact replacement to original dryer. Dryer removes moisture and should be changed anytime system is recharged. It is the life

of your system. Stainless steel filter element. Filter stops contaminants from clogging expansion valve.

### Dryer, Filter

64-66	.....	C4AZ-19959-B
67-68	.....	C7Z-19959-A
69-70	.....	C9Z-19959-A
71-73	.....	D1Z-19959-A

**DRYER MOUNTING BRACKET**



Made by Scott Drake. Exact detail. Painted flat black. Mounting hardware included.

Dryer Mounting Bracket  
64-66 .....C5ZZ-19838-A

**EVAPORATOR**



All new high output coils with more tubing passes makes these evaporators perform much better than the original coils. New

copper tube coils eliminate corrosion problem that plague aluminum versions.

**Evaporator**

64-65 Factory Under Dash .....C5ZZ-19860-A  
66 .....C6ZZ-19860-A  
67-68 .....C7ZZ-19860-A  
69-70 Late 69 .....C9ZZ-19860-B  
71-73 .....D1ZZ-19860-A

**EXPANSION VALVE**



**Expansion Valve**

64-66 .....C5ZZ-19849  
67-68 .....C7ZZ-19849  
69-70 .....C9ZZ-19849  
71-73 .....D1ZZ-19849

**FIREWALL AIR CONDITIONER HOSE GROMMET**



Firewall Air Conditioner Hose Grommet  
64-66 .....C5ZZ-198588-A

**FIREWALL GROMMET BRACKET**

Painted black to prevent corrosion.



Firewall Grommet Bracket  
64-66 .....C5ZZ-198589-A

**HEATER & AC CONTROL KNOBS**

These exact reproductions are a great finishing touch. Made from die cast zinc and

heavily chrome plated for durability. Black and chrome lettering on 64-68 versions is crisp and clear.

**Heater & AC Control Knobs**



64-66: Heater, chrome  
C5DZ-18519-K



64-66: Heater, satin  
C5DZ-18519-K



67: Air conditioner  
C7ZZ-18519-ACK



67: Non A/C  
C7ZZ-18519-AK



68: Air conditioner  
C8ZZ-18519-ACK e



68: Non A/C  
C8ZZ-18519-AK



69-70: Heater, chrome plated plastic  
C9ZZ-18519-A

**HEATER AND AIR CONDITIONER VACUUM LINE HOSE KIT**

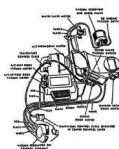

This kit includes color coded rubber hose, 2 plastic "T" connectors and vacuum diagram.

Heater And Air Conditioner Vacuum Line Hose Kit  
67-68 .....C7ZZ-188372-A

**IDLER BEARING REPAIR KIT**



Repair your own idler bearings. Includes dust cover.

Idler Bearing Repair Kit  
64-70 .....C5ZZ-2990-A

**IDLER PULLEY AND BRACKET**



Quality rebuilds, core not required.

**Idler Pulley And Bracket**

65-66 Adjustable .....C5ZZ-8678-B  
65-66 Non-adjustable .....C5ZZ-8678-C  
68 Adjustable .....C8ZZ-8678-A

**LIQUID LINE HOSE ASSEMBLY**



Connects to filter dryer outlet and extends through radiator core support.

**Liquid Line Hose Assembly**

64-66 .....C5ZZ-19837-A

**QUICK DISCONNECT FITTING**

Manufactured by the original maker to the original specifications. Features concours markings stamped into fitting.

**Quick Disconnect Fitting**



67-73: Female  
C7ZZ-19B596-F



67-73: Male/Female  
C7ZZ-19B596-M/F

**SERVICE VALVE**



Fits on top of compressor. Exact copy. For aluminum valve cap see below. Aftermarket plastic cap included. #8 are

smaller and are the discharge hose, #10 is the larger size for the suction side of hose.

**Service Valve**

64-66 Flare/Rotolock, discharge .C5ZZ-19752-A  
67-68 Flare/Rotolock, suction ....C7ZZ-19752-A  
69 O-ring/Rotolock, discharge .....  
C9ZZ-19752-D  
69 O-ring/Rotolock, suction ..C9ZZ-19752-S  
70-73 O-ring/Tube-O, discharge D1ZZ-19752-D  
70-73 O-ring/Tube-O, suction ....D1ZZ-19752-S

Heater & AC

**WE PROUDLY FEATURE AUTHENTIC MUSTANG REPRODUCTIONS FROM SCOTT DRAKE ENTERPRISES!**





### SERVICE VALVE CAPS



Aluminum caps which fit on the service valves, these are exact copies. A must for any detailed engine compartment.

**Service Valve Caps**  
64-73 .....CSZZ-19752-C

### SIGHT GLASS HOSE



High quality US made hose. Not exact copy of original but great for daily drivers.

**Sight Glass Hose**  
64 6 and 8 cylinder .....CSZZ-19837-C  
67-68 6 and 8 cylinder with 90 degree fitting ..  
C7ZZ-19837-A  
69-70 6 and 8 cylinder .....C9ZZ-19837-A  
70-73 6 and 8 cylinder .....D1ZZ-19837-A

### SUCTION HOSE



Constructed in original Ford style black thermoplastic material with nylon barrier. All hose assemblies are built compliant for

R-12 or 134a refrigerants.  
**Suction Hose**  
64-65 8 cylinder, concours .....CSZZ-19864-8  
64-65 6 cylinder, concours .....CSZZ-19867-6  
66 6 cylinder, concours .....C6ZZ-19864-6  
66 8 cylinder, concours .....C6ZZ-19864-8  
66 8 cylinder, economy .....C6ZZ-19864-8R  
67-68 6 cylinder, concours .....C7ZZ-19864-6  
67-68 8 cylinder, concours .....C7ZZ-19864-8  
69-70 8 cylinder, concours .....C9ZZ-19864-8  
71-73 6 cylinder, concours .....D1ZZ-19864-6  
71-73 8 cylinder, concours .....D1ZZ-19864-8

### VACUUM CANISTER



Mounts to passenger fender well. Controls doors inside AC unit, includes built in check valve.

**Vacuum Canister**  
67-70 .....C8ZZ-19A566

## HEATER

### LEFT HAND AIR VENT INLET GASKET



This is the seal for the air vent housing on the drivers (left hand) side, under the dash on Mustangs from 1964 through 1968.

**Air Vent Inlet Gasket, Left Hand**  
64-68 .....C20Z-6501999

### HEATER BLOWER MOTOR FAN SWITCH

**Blower Motor Fan Switch, Heater**



64-65: 2 speed, before 4/1/65  
C4DZ-18578



65-66: 3 speed  
C5ZZ-18578



67  
C7ZZ-19986



68  
C8ZZ-19986

### BLOWER MOTOR FAN SWITCH (FOR AC CARS)

Blower motor fan switch for cars equipped with factory in-dash AC. Dash mounted control switch.

**Blower Motor Fan Switch (for AC Cars)**



67  
C7ZZ-19986-AC



68  
C8ZZ-19986-AC



69-70  
C9ZZ-19986-AC

### DEFROSTER CONTROL CABLE

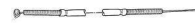

These parts are exactly like the originals. They feature correct cable covers, color coding, wire type and ends.

**Defroster Control Cable**  
64-66 Defroster .....C4DZ-18548-A

### DEFROSTER DUCT

A nice reproduction. 67-68 features wire mesh screen like original.

**Defroster Duct**



64-66: Pair with clips  
C5ZZ-18490-A



67-68: Left hand without air conditioner  
C7ZZ-18490-L



67-68: Right hand without air conditioner  
C7ZZ-18490-R

### DEFROSTER DUCT CLIP



These clips hold the defroster outlet nozzles to the dashboard. Four (one set) are required for a complete installation.

**Defroster Duct Clip**  
64-70 Set of 4 .....372850-5

### DEFROSTER DUCT KIT



Complete kit includes two hoses with outlet ducts attached, and installation clips.

**Defroster Duct Kit**  
64-66 .....C5ZZ-18490-K

### DEFROSTER HOSE



We also sell defroster hoses individually. Hose is authentic flex style, made from original type polypropylene coated

fabric. Available with or without cam-locks which will provide a quick secure installation.

**Defroster Hose**

64-70 .....B5A-18556-C  
64-70 with cam-locks .....CSZZ-18556-A

**HEATER & AC CONTROL KNOBS**

These exact reproductions are a great finishing touch. Made from die cast zinc and heavily chrome plated for durability. Black and chrome lettering on 64-68 versions is crisp and clear.

**Heater & AC Control Knobs**

 64-66: Heater, chrome  
C5DZ-18519-K

 64-66: Heater, satin  
C5DZ-18519-KS

 67: Air conditioner  
C7Z-18519-ACK

 67: Non A/C  
C7Z-18519-AK

 68: Air conditioner  
C8Z-18519-ACK

 68: Non A/C  
C8Z-18519-AK

 69-70: Heater, chrome plated plastic  
C9Z-18519-A

**HEATER BLOWER MOTOR**

High quality replacement part at a reasonable price.

**Heater Blower Motor**

 64-65: 2-speed  
CODZ-18527-A

 65-68: 3-speed motor, will not work with early 65 cars with 3 wired, 2 speed motors  
CSZZ-18527-B

 65-68: 3-speed motor with squirrel cage(fan)  
CSZZ-18527-K

**Heater Blower Motor**

 67-73: With Air Conditioner  
C7Z-18527-A

 69-73: Without Air Conditioner  
C9Z-18527-A

**HEATER BLOWER MOTOR TO FIREWALL NUT**

 Concours correct nuts with sealer.

**Heater Blower Motor to Firewall Nut**  
64-73 ..... 370546-S

**HEATER BOX ASSEMBLY**

 Complete heater box assembly, features fiberglass box and steel stamped air chamber whirl cage. Motor is not included.

**Heater Box Assembly**  
64-65 2 speed .....CSZZ-18A542-K  
65-66 3 speed .....C6ZZ-18A542-K  
67-68 3 speed .....C7ZZ-18A542-K  
69-70 With gasket and clips .C9ZZ-18A542/3-A

**HEATER BOX CASE CLAMP**

 Special steel clamps that hold both halves of the heater box together.

**Heater Box Case Clamp**  
64-68 ..... CODF-19A779-A

**HEATER CONTROL CABLE**

 These parts are exactly like the originals. They feature correct cable covers, color coding, wire type and ends.

**Heater Control Cable**  
64-66 Defroster ..... C4DZ-18548-A  
64-66 Heat, Temperature and Defrost .....  
CSZZ-18518-52-K  
64-66 Temperature .....CSZZ-18518-B  
64-66 Heat control .....CSZZ-18552-A  
67-68 Without air conditioner ...C7ZZ-18518-A  
67-68 With air conditioner .....C7ZZ-18518-B

**Heater Control Cable**

69-73 W/out AC ..... D1ZZ-18518-A

**HEATER CONTROL VALVE**

This is used on cars equipped with factory Air Conditioning to stop the flow of warm coolant when AC is on. Not exact replacement.

**Heater Control Valve**

 67-68: OEM type  
C7ZZ-18495-A

 69-73  
D4AZ-18495-A

**HEATER CORE**

 Our heater cores are the finest available anywhere for any price. Constructed from corrosion resistant copper and brass. A great buy for anyone needing to make repairs to this vital part.

**Heater Core**

64-68 Without air conditioner ..C5DZ-18476-A  
64-68 Aluminum .....C5DZ-18476-AL  
67-73 With air conditioner .....C9ZZ-18476-B  
69-70 Without air conditioner ...C9ZZ-18476-A  
71-73 Without air conditioner .. D1ZZ-18476-B

**HEATER CORE END CAP**

 These foam rubber end caps protect the core from damage due to excessive vibration. Prevents rattles and improves heater performance with better sealing of the box.

**Heater Core End Cap**

65-68 Without air conditioner ...C5ZZ-18500-C  
67-73 With air conditioner .....C7ZZ-18500-C

**HEATER CORE TO CONTROL VALVE**

**HOSE**

 Both ends have 90 degree molded ends. Attaches heater core to water control valve. AC cars only.

**Heater Core To Control Valve Hose**

67-68 .....C7ZZ-18472-CVAC  
69-73 .....C9ZZ-18472-CVAC

Heater & AC

**WE PROUDLY FEATURE AUTHENTIC MUSTANG REPRODUCTIONS FROM SCOTT DRAKE ENTERPRISES!**



### HEATER DASH PLATE



Our reproduction heater dash plate is a fine pressure die-cast zinc unit made to Scott Drake's high standards. Excellent chrome

plating on face. Includes mounting studs and nuts. See Audio section for 69-70 Radio/Heater Dash Plate.

#### Heater Dash Plate

- 64-66 Chrome .....CSZZ-18A651
- 64-66 Satin .....CSZZ-18A651-S

### HEATER HOSE



These are the exact copies, approved by Mustang Club of America. They feature the correct grooves running the length

of the hose, correct colored stripe and part numbers, air conditioned cars have a 90 degree bend on one end of the hose when appropriate. Colored markings are very durable and don't come off easily. Below part numbers are for our reference only and do not reflect part numbers on actual hoses.

#### Heater Hose

- 64-68 64-early 68, white stripe .CSZZ-18472-W
- 67-68 67-early 68 w/ AC, white stripe .....C7ZZ-18472-ACW

- 68 After 2-1-68 w/ AC, red stripe .....C8ZZ-18472-ACR

- 68 All After 2-1-68, red stripe C8ZZ-18472-R

- 68-69 w/out AC, red stripe .....CSZZ-18472-R

- 69 w/ AC, red stripe .....C9ZZ-18472-ACR

- 69 Red stripe .....C9ZZ-18472-R

- 70 before 2-1-70, yellow stripe .....D0ZZ-18472-AY

- 70 after 2-1-70 w/ AC, yellow stripe .....D0ZZ-18472-BACY

- 70 After 2-1-70, yellow stripe .....D0ZZ-18472-BY

- 70-73 w/out AC, yellow stripe ...CSZZ-18472-Y

- 71 w/ AC, yellow stripe ....D1ZZ-18472-ACY

- 71-73 Yellow stripe .....D1ZZ-18472-Y

- 72 w/ AC, yellow stripe ....D2ZZ-18472-ACY

- 72 Yellow stripe .....D2ZZ-18472-Y

- 73 w/ AC, yellow stripe ....D3ZZ-18472-ACY

- 73 Yellow stripe .....D3ZZ-18472-Y

### HEATER HOSE KIT



Generic replacement hoses are American made. Black hose includes four original style post-type clamps.

#### Heater Hose Kit

- 64-68 Generic .....CSZZ-18472-K

### SHOW QUALITY HEATER HOSE KIT



These show quality hoses include original style 5/8-inch inside diameter ribbed hose with 1/4" wide white stripe, plus four post-

type band clamps.

#### Heater Hose Kit, Show quality

- 64-66 Show quality .....CSZZ-18472-WK

### FIREWALL HEATER HOSE PLUG



Rubber plug for heater core or a/c holes on non-air conditioned cars.

#### Heater Hose Plug, Firewall

- 67-68 .....377678-S2

### HEATER INLET GASKET



This gasket seals the fresh air tube in the cowl to the heater box inlet on 1964 through 1970 Mustangs.

#### Heater Inlet Gasket

- 64-70 .....CSZZ-18A569-A

### HEATER JUMPER HARNESS



Connects heater switch to engine gauge harness which plugs into heater motor.

#### Heater Jumper Harness

- 64-65 2 speed only .....CSZZ-18570-JMP

### HEATER PLENUM



Our replacement heater plenums are molded from virgin ABS plastic for good looks and durability. Cable clamp and screw

are attached, and inner door has closed cell foam bumpers installed.

#### Heater Plenum

- 64-68 View box packaging .....CSZZ-18471-A

- 64-68 Bulk, multiples of 10 only CSZZ-18471-B

### HEATER RESISTOR ASSEMBLY



#### Heater Resistor Assembly

- 65-67 3 speed .....C20A-18591-A

- 67 3-speed, w/ AC .....C7ZZ-19A706-A

#### Heater Resistor Assembly

- 68-73 3-speed, w/ AC .....C8ZZ-19A706-A

### HEATER SEAL KIT



Everything you need to completely reseal the heater system and make it perform at top efficiency. Kit includes all foam seals and

rubber gaskets required for the entire heater system.

#### Heater Seal Kit

- 64-66 All .....CSZZ-18500-A

- 67-68 Without air conditioner ...C7ZZ-18500-A

- 67-68 With air conditioner .....C7ZZ-18500-B

- 69-70 With air conditioner .....C9ZZ-18500-A

- 69-70 Without air conditioner ...C9ZZ-18500-B

### BYPASS HOT WATER ELBOW

These beautiful reproductions replace rusty and corroded originals. Also available in chrome for V8.

#### Hot Water Elbow, Bypass



- 65-72: 6 cylinder  
8M-18599



- 64-68: 170, 200 silver zinc  
C20Z-18599-B



- 64-73: Small block, gold zinc  
C6AZ-18599-B



- 64-73: Small block, chrome  
C6AZ-18599-C



- 64-73: Small block, silver zinc  
C6AZ-18599-S



- 67-68: Big block, gold zinc  
C8AZ-18599-A



- 67-68: Big block, chrome  
C8AZ-18599-C



- 69-70: Boss 302, w/water restrictor,  
silver zinc  
C9ZZ-18599-A

**Hot Water Elbow, Bypass**



69-70: 428, silver zinc  
D0AZ-18599-B

69-73: 351, 390, silver zinc  
D0AZ-18599-A

70-71: 351, 390, chrome  
D0AZ-18599-C

**WATER VALVE BRACKET**



Exact reproduction with zinc dichromate finish.

**Water Valve Bracket**

67-68 .....C7Z-18A635-A

**INTERIOR PARTS & UPHOLSTERY**

**BEZELS, KNOBS, SPACERS, AND CIGARETTE LIGHTERS**

**DASH ASH TRAY**

This is an exact copy to the original, not the hand fabricated part assembled with generic pop rivets that is also available. Best Quality at the Best Price. Painted Black with correct zinc plated housing. Note: console and quarter panel ash trays can be found in the "Console" and "Quarter Panel" sections of this category. **Ash Tray, Dash**



64-66  
CSZ-6204810-A



67: Note: will not fit 68  
C7Z-6204810-A

**DASH BEZEL AND KNOB KIT**

Our six piece kit includes ignition bezel, light switch knob and bezel, wiperknob and bezel, and a cigarette lighter element and knob assembly. \*Deluxe kit includes headlamp and wiper retaining nuts.

**Bezel and Knob Kit, Dash**



65-66: Deluxe  
CSZ-10852-DLXK



65-66  
CSZ-10852-K



67-68: Bezels & Knobs  
C7Z-10852-K

**BEZEL INSTALLATION TOOL**



These dedicated tools are perfect for installing or removing various bezels on your Mustang.

**Bezel Installation Tool**

67 .....1967 CV Top Switch Bezel & 2010  
Antenna Bezel ..... T-67

**CIGARETTE LIGHTER**

These are the best on the market and we invite comparison with any other lighter assembly available. Includes die-cast chromed knob and lighter element with shell. Exactly like the originals.

**Cigarette Lighter**



64-66  
CSZ-15052-K



67-70  
C7AZ-15052-K

**CIGARETTE LIGHTER BEZEL AND ELEMENT**

Excellent detailing and chrome plating. Like originals.

**Cigarette Lighter Bezel and Element**



64-66  
C4DZ-15054-A

**Cigarette Lighter Bezel and Element**



70  
D0ZZ-10852-L

**CIGARETTE LIGHTER KNOB**

Excellent detailing and chrome plating. Like originals.

**Cigarette Lighter Knob**



64-66  
CSZ-15052-A



70  
D0ZZ-15052

**CIGARETTE LIGHTER SOCKET AND RETAINER**



Made by the original supplier. Fits our cigarette lighters.

**Cigarette Lighter Socket and Retainer**

64-70 ..... C4AZ-15055-B

**CONTROL PANEL BEZELS AND LENSES**



Made by Drake! These bezel & lenses are an excellent reproduction of a rare option. Fits both dash and console versions.

**Control Panel Bezels and Lenses**

67-68 .....C7Z-10C876-KIT

**CONVERTIBLE TOP SWITCH**

Exact copy from Scott Drake. For 64-66 knob & bezel sold separately.

**Convertible Top Switch**



64-66  
C4DZ-15668-A



67: Includes bezel and knob  
C7Z-15668-A



69-70  
C9Z-15668 A

Interior

**WE PROUDLY FEATURE AUTHENTIC MUSTANG REPRODUCTIONS FROM SCOTT DRAKE ENTERPRISES!**



### Convertible Top Switch



71-73  
D1ZZ-15668

### CONVERTIBLE TOP SWITCH BEZEL AND KNOB



Quality chrome plated with black painted "UP" and "DN" markings.

Convertible Top Switch Bezel and Knob  
64-66 ..... C4DZ-10852-K

### EMERGENCY FLASHER BEZEL



This commonly broken piece is now made by Scott Drake! Using ABS construction this part is made from Ford's original print for exact detail. For fixed columns only.

Emergency Flasher Bezel  
67 ..... C70Z-15C580-A

### EMERGENCY FLASHER KNOB



Machined brass, exact shape and threads as originals.

Emergency Flasher Knob  
67 Non-tilt ..... C70Z-17513-A  
67 Tilt ..... C70Z-17513-B  
68-69 Tilt ..... C8MY-17513-C

### FOG LIGHT SWITCH KNOB AND BEZEL



Nice touches for corroded or missing original parts.

Fog Light Switch Knob and Bezel  
65-67 ..... C5ZZ-15259-AK

### HEADLIGHT SWITCH BEZEL

New, chrome bezels really make a freshly painted dash pop. Beautiful reproductions.



64-66  
C4DZ-10852-B

### Headlight Switch Bezel



67-68  
C7Z-10852-A



69-70  
C9Z-10852-L

### HEADLIGHT SWITCH COVER



Molded rubber cover which fits over headlamp dimmer switch.

Headlight Switch Cover  
65-73 ..... C5Z-13533

### HEADLIGHT SWITCH KNOB

Knob is die-cast zinc, chrome plated with very good detail. Switch shaft is zinc plated to prevent rust or corrosion.

#### Headlight Switch Knob



64  
C4Z-11661-A



65-66  
C5Z-11661-B



67-68  
C7Z-11661-A



69-70  
C9Z-11661

### HEADLIGHT SWITCH RETAINING NUT



Beautiful chrome retaining nut that holds headlight switch into the dash. These were previously difficult to find. Made

from original factory prints.  
Headlight Switch Retaining Nut  
65-66 ..... C5Z-11650-A  
67-68 ..... C7Z-11650-A

### HEATER & AC CONTROL KNOBS

These exact reproductions are a great finishing touch. Made from die cast zinc and heavily chrome plated for durability. Black and chrome lettering on 64-68 versions is crisp and clear.

#### Heater & AC Control Knobs



64-66: Heater, chrome  
C5DZ-18519-5E



64-66: Heater, satin  
C5DZ-18519-KS



67: Air conditioner  
C7Z-18519-ACK



67: Non A/C  
C7Z-18519-AK



68: Air conditioner  
C8Z-18519-AK



68: Non A/C  
C8Z-18519-AK



69-70: Heater, chrome plated plastic  
C9Z-18519-A

### HEATER DASH PLATE



Our reproduction heater dash plate is a fine pressure die-cast zinc unit made to the highest standards. Excellent chrome

plating on face. Includes mounting studs and nuts.

#### Heater Dash Plate

64-66 Chrome ..... C5Z-18A651  
64-66 Satin ..... C5Z-18A651-S

### IGNITION BEZEL TOOL



Don't scratch that new bezel or freshly painted dash with a screw driver. A dedicated tool made by Scott Drake.

Ignition Bezel Tool  
67-68 ..... T-100-YL

**Ignition Bezel Tool**

69 ..... T-109-CL

**IGNITION SWITCH BEZEL**

High Quality Chrome. Don't forget to check out our bezel tool made specifically for this bezel to prevent damage. **1969 Chrome Ignition Bezel Spacer will be available Summer 2012 under part number "C9ZZ-11574."**

**Ignition Switch Bezel**



64-66  
C3AZ-11584-A



67-68  
C60Z-11584-A



69  
C9AZ-11584-A

**RADIO AND HEATER BEZEL INSERT**



Wood vinyl covering for radio and heater bezels. Walnut.

**Radio and Heater Bezel Insert**

69-70 Wood vinyl .....WG-130-V

**IGNITION SWITCH RETAINER**

A "must have" part when installing an ignition switch. Zinc plated for years of service.

**Ignition Switch Retainer**



64-66  
C4DZ-10A885-A



67-68  
C7ZZ-11A590-B

**RADIO BEZEL**

**Radio Bezel**



67-68: Black/chrome, without console  
C8Z-18842-AR

**Radio Bezel**



69-70: Black/chrome  
C9ZZ-6504774-B



69-70: Walnut woodgrain  
C9ZZ-6504774-F



71-73: Black/chrome  
D1ZZ-18842-A

**RADIO KNOB AND DIAL SET**



Pressure die cast construction. Not cheap light weight plastic. Chrome plated and concurs correct.

**Radio Knob and Dial Set**

64-66 .....C4AZ-18817/30-A  
69-70 .....C9ZZ-18817-K

**TURN SIGNAL LIGHT LEVER -**

**SHORT**



Same quality as our standard length Turn Signal Light Levers, but in a 5 1/2" length. Perfect for smaller diameter steering

wheels.

**Turn Signal Light Lever - Short**

64-66 ..... S1MS-13305-A  
67-73 ..... S7MS-13305-A

**TURN SIGNALL LIGHT LEVER**

Perfect copies to replace those rusted or tweaked originals. Swedged like originals, not machined like competitors.

**Turn Signall Light Lever**



64-66: Chrome  
C5ZZ-13305-A



64-66: Satin  
C5Z-13305-S



67-73: Chrome  
C7Z-13305-A

**Turn Signall Light Lever**



67-73: Satin  
C7Z-13305-S

**WINDSHIELD WIPER SWITCH RETAINING NUT**



This beautifully chromed nut holds the wiper switch into the dash. This nut is almost always damaged from improper tools

used for removal and installation. Made from original factory prints.

**Windshield Wiper Switch Retaining Nut**

65-66 ..... C4DZ-17512-A

**WIPER BEZEL STEM NUT TOOL**



Special tool designed to insert into wiper bezel stem nut used for assembly or disassembly. Will not damage nut.

**Wiper Bezel Stem Nut Tool**

64-66 ..... T-110-RD

**WIPER KNOB**

Excellent reproductions. Chrome plating, look like originals.

**Wiper Knob**



64-66  
C4AZ-17513-A



69-70  
C9ZZ-17513

**WIPER SWITCH BEZEL**

A beautiful chrome and black reproduction of the original.

**Wiper Switch Bezel**



64-66  
C4DZ-10852-A



69  
C9ZZ-10852-W

Interior

**WE PROUDLY FEATURE AUTHENTIC MUSTANG REPRODUCTIONS FROM SCOTT DRAKE ENTERPRISES!**



109

### WIPER SWITCH SPACER



Used to install wiper switch to dash. Once a hard part to find now available for trouble free installations. Plated.

**Wiper Switch Spacer**  
64-66 .....C4DZ-17C443-A

### FIREWALL INSULATOR



Features bonded thermal insulation. Mounting kit included. Die cut for a good fit or molded for a perfect fit.

**Firewall Insulator**  
64-66 Die-cut, economy ..... C5ZZ-6501670-A  
64-66 All Molded..... MUST-6466-C  
67-68 Die-cut, economy ..... C7ZZ-6501670-A  
67-68 w/o Factory AC Molded .. MUST-6768-HC  
69-70 Die-cut, economy ..... C9ZZ-6501670-A  
71-73 Die-cut, economy ..... D1ZZ-6501670-A

### ACCOUSTISHIELD FIREWALL INSULATOR



QuietRide Mustang Firewall Insulators are vacuum molded from a high definition rubber material to fit the exact contours of

the humps and heater wells of the Mustang cars. Firewall insulators are year make and model specific for heater only cars, Factory AC cars and Mach I cars. HeatShield insulation is added for increased thermal acoustic stop engine heat and noise from entering the passenger cabin. All factory holes are punched or perforated for easy installation. Concours quality. Mounting pins included.

**Firewall Insulator, AcoustiShield**  
64-66 All ..... C5ZZ-6501670-M  
67-68 w/Factory AC ..... MUST-6768-AC  
6768 w/o Factory AC ..... C7ZZ-6501670-M  
69-70 All ..... MUST-6970-C  
69-70 All Mach1 ..... MUST-6970-CMI  
See "Sheet Metal" section for complete kits.

## CARPET, FLOOR MATS, & UNDERLAYMENT

### CONVERTIBLE CARPET KIT



This is the good stuff. 1964-1968 are constructed from 80% Rayon 20 % Nylon, 1969-1970 are 100% Nylon. All edges are

sewn to prevent unraveling. Drivers side has molded, colored keyed rubber heel and toe pad. All carpet is backed with a heavy 27 ounce jute insulation layer. Also features a precut gearshift hole. Fastbacks include small lower quarter panel sections.

**Carpet Kit, Convertible**  
64 Black ..... CAR64-CV-BK  
65-68 Aqua ..... CAR65-CV-AQ  
65-68 Bright blue ..... CAR65-CV-BB  
65-68 Black ..... CAR65-CV-BK  
65-68 Dark brown ..... CAR65-CV-BN  
65-68 Bright red ..... CAR65-CV-BR  
65-68 Dark blue ..... CAR65-CV-DB  
65-68 Dark green ..... CAR65-CV-DG  
65-68 Dark saddle ..... CAR65-CV-DS  
65-68 Emberglow ..... CAR65-CV-EM  
65-68 Ivy gold ..... CAR65-CV-IG  
65-68 Maroon ..... CAR65-CV-MR  
65-68 Nugget gold ..... CAR65-CV-NG  
65-68 Saddle ..... CAR65-CV-SA  
69-70 Black ..... CAR69-CV-BK  
69-70 Dark blue ..... CAR69-CV-DB  
69-70 Dark green ..... CAR69-CV-DG  
69-70 Ginger ..... CAR69-CV-GI  
69-70 Maroon ..... CAR69-CV-MR  
70 Vermillion ..... CAR69-CV-VE  
71-73 Black ..... CAR71-CV-BK  
71-73 Medium blue ..... CAR71-CV-BL  
71-73 Ginger ..... CAR71-CV-GI

### COUPE CARPET KIT



This is the good stuff. 1964-1968 are constructed from 80% Rayon 20 % Nylon, 1969-1970 are 100% Nylon. All edges are

sewn to prevent unraveling. Drivers side has molded, colored keyed rubber heel and toe pad. All carpet is backed with a heavy 27 ounce jute insulation layer. Also features a precut gearshift hole. Fastbacks include small lower quarter panel sections.

**Carpet Kit, Coupe**  
64 Black ..... CAR64-CP-BK  
64 Red ..... CAR64-CP-BR  
64 Dark blue ..... CAR64-CP-DB  
65-66 Dark teal ..... CAR65-6-CP-DT  
65-68 Aqua ..... CAR65-CP-AQ  
65-68 Bright blue ..... CAR65-CP-BB  
65-68 Black ..... CAR65-CP-BK  
65-68 Dark brown ..... CAR65-CP-BN  
65-68 Red ..... CAR65-CP-BR

### Carpet Kit, Coupe

65-68 Dark blue ..... CAR65-CP-DB  
65-68 Dark green ..... CAR65-CP-DG  
65-68 Dark saddle ..... CAR65-CP-DS  
65-68 Emberglow ..... CAR65-CP-EM  
65-68 Ivy gold ..... CAR65-CP-IG  
65-68 Maroon ..... CAR65-CP-MR  
65-68 Nugget gold ..... CAR65-CP-NG  
65-68 Saddle ..... CAR65-CP-SA  
69-70 Black ..... CAR69-CP-BK  
69-70 Dark brown ..... CAR69-CP-BR  
69-70 Dark blue ..... CAR69-CP-DB  
69-70 Dark green ..... CAR69-CP-DG  
69-70 Ginger ..... CAR69-CP-GI  
69-70 Maroon ..... CAR69-CP-MR  
69-70 Vermillion ..... CAR69-CP-VE  
71-73 Black ..... CAR71-CP-BK  
71-73 Blue ..... CAR71-CP-BL  
71-73 Bright red ..... CAR71-CP-BR  
71-73 Dark green ..... CAR71-CP-DG  
71-73 Ginger ..... CAR71-CP-GI

### ECONOMY CARPET KIT



These are quality molded carpet sets made from 100% nylon, and available at a lower price than our standard carpet kits.

Available for 65-68 coupes, convertibles, and fastbacks.

**Carpet Kit, Economy**  
65-68 Coupe, black ..... CAR-65-CP-BK-N  
65-68 Convertible, black ..... CAR-65-CV-BK-N  
65-68 Fastback, black ..... CAR-65-FB-BK-N

### FASTBACK CARPET KIT



This is the good stuff. 1964-1968 are constructed from 80% Rayon 20 % Nylon, 1969-1970 are 100% Nylon. All edges are

sewn to prevent unraveling. Drivers side has molded, colored keyed rubber heel and toe pad. All carpet is backed with a heavy 27 ounce jute insulation layer. Also features a precut gearshift hole. Fastbacks include small lower quarter panel sections.

**Carpet Kit, Fastback**  
65-68 Aqua ..... CAR65-FB-AQ  
65-68 Bright blue ..... CAR65-FB-BB  
65-68 Black ..... CAR65-FB-BK  
65-68 Dark brown ..... CAR65-FB-BN  
65-68 Bright red ..... CAR65-FB-BR  
65-68 Dark blue ..... CAR65-FB-DB  
65-68 Dark green ..... CAR65-FB-DG  
65-68 Dark saddle ..... CAR65-FB-DS  
65-68 Emberglow ..... CAR65-FB-EM  
65-68 Ivy gold ..... CAR65-FB-IG  
65-68 Maroon ..... CAR65-FB-MR

### Carpet Kit, Fastback

65-68	Nugget gold	CAR65-FB-NG
65-68	Saddle	CAR65-FB-SA
69-70	Black	CAR69-FB-BK
69-70	Dark blue	CAR69-FB-DB
69-70	Dark green	CAR69-FB-DG
69-70	Ginger	CAR69-FB-GI
69-70	Maroon	CAR69-FB-MR
70	Vermillion	CAR69-FB-VE
71-73	Black	CAR71-FB-BK
71-73	Blue	CAR71-FB-BL
71-73	Dark green	CAR71-FB-DG
71-73	Ginger	CAR71-FB-GI

### MACH 1 CARPET KIT

 1969 has four rubber inserts just like originals, specify colors. 1970 has 2 rubber inserts. 1971-1973 have two rubber inserts with correct embossed horse.

#### Carpet Kit, Mach 1

69	Black, with black inserts	CAR69-M-BK/BK
69	Black, with red inserts	CAR69-M-BK/RD
70	Black, with black inserts	CAR70-M-BK/BK
70	Black, with gray inserts	CAR70-M-BK/GY
70	Blue, with blue inserts	CAR70-M-BL/BL
71-73	Black, with black inserts	CAR71-M-BK/BK
71-73	Black, with gray inserts	CAR71-M-BK/GR
71-73	Blue, with blue inserts	CAR71-M-BL/BL
71-73	Ginger, with ginger inserts	CAR71-M-GI/GI

### CARPET FLOOR MAT

 Aftermarket replacements made by Auto Custom Carpet. Made from the 80/20 blend so this will match 1964-1968 styles. Features rubber backing with anti-slip spikes. All are complete four piece sets, both fronts and two rears. See "Sheet Metal Section" for complete Sound Deadner Kit as well as premium upgrade options.

#### Floor Mat, Carpet

64-73	Black, no logo	ACC-FM-BK
64-68	Bright blue, no logo	ACC-FM-BB
64-73	Dark blue, no logo	ACC-FM-DB
64-73	Bright red, no logo	ACC-FM-BR
64-73	Ginger, no logo	ACC-FM-GI
64-73	Ivy gold, no logo	ACC-FM-IG
64-73	Maroon, no logo	ACC-FM-MR





### Floor Mat, Carpet

65-68	Turquoise, no logo	ACC-FM-TQ
-------	--------------------	-----------

### CARPET UNDERLAYMENT KIT

Kits include heavy duty die cut E.V.A. type rubber pad which aids against carpet ware, especially around sharp contoured floor areas. Helps insulate sound and temperature. See **Sheet Metal section for complete Sound Deadner Kit as well as premium upgrade options.**

#### Underlayment Kit, Carpet

	64-73: Coupe/fastback, front and rear footwells	UL-1
	64-73: Convertible, front and rear footwells	UL-3
	64-73: Transmission hump	UL-4
	65-68: Trunk	UL-5

### CUSTOM FIT, MUSTANG CARPET FLOOR MAT

 The same quality as our embroidered floor mats. Features a full-size fit.

Available for coupe/fastback and convertible.

#### Floor Mat, Custom Fit, Mustang Carpet

64-73	Coupe/fastback, aqua*	ACC-FM-CPFB-AQ
64-73	Coupe/fastback, bright blue*	ACC-FM-CPFB-BB
64-73	Coupe/fastback, black*	ACC-FM-CPFB-BK
64-73	Coupe/fastback, bright red*	ACC-FM-CPFB-BR
64-73	Coupe/fastback, dark blue*	ACC-FM-CPFB-DB
64-73	Coupe/fastback, emberglow*	ACC-FM-CPFB-EM
64-73	Coupe/fastback, ginger*	ACC-FM-CPFB-GI
64-73	Coupe/fastback, green*	ACC-FM-CPFB-GR
64-73	Coupe/fastback, ivy gold*	ACC-FM-CPFB-IG
64-73	Coupe/fastback, maroon*	ACC-FM-CPFB-MR
64-73	Convertible, aqua*	ACC-FM-CV-AQ

### Floor Mat, Custom Fit, Mustang Carpet

64-73	Convertible, bright blue*	ACC-FM-CV-BB
64-73	Convertible, black*	ACC-FM-CV-BK
64-73	Convertible, bright red*	ACC-FM-CV-BR
64-73	Convertible, dark blue*	ACC-FM-CV-DB
64-73	Convertible, ivy gold*	ACC-FM-CV-IG
64-73	Convertible, maroon*	ACC-FM-CV-MR

### HEAVY PLUSH FLOOR MAT

 These heavy, plush floor mats are made by Lloyd Mats, and come in a set with two front mats and two rear mats. Front mats feature either the Mustang Running Horse logo, or Mustang tri-bar logo. Available in black only.

**Floor Mat, Heavy Plush**

64-73	Coupe with running horse*	ACC-FM-CP-BK-RH
64-73	Coupe with tri-bar logo*	ACC-FM-CP-BK-TB
64-73	Coupe with Tiffany Snake logo <sup>5</sup>	ACC-FM-CP-BK-TS
64-73	Convertible with running horse*	ACC-FM-CV-BK-RH
64-73	Convertible with tri-bar logo*	ACC-FM-CV-BK-TB

### EMBROIDERED, COBRA CARPET FLOOR MAT FROM ACC

 The Classic Cobra logo in red, white & blue, embroidered on black carpeted floor mats. Carpet is 80/20 blend to match 1964-68 carpets from ACC. Features rubber backing with anti-slip spikes. Logo is featured on front mats.

#### Floor Mat from ACC, Embroidered, Cobra Carpet

	64-73: Black, classic Cobra <sup>5</sup>	ACC-FM-COBRA-BK
	64-73: Black/silver, Tiffany snake <sup>5</sup>	ACC-FM-SNAKE-BK

### EMBROIDERED, MUSTANG CARPET FLOOR MAT FROM ACC

 Made by Auto Custom Carpet out of the same 80/20 blend as our 1964-1968 carpet for a perfect match. They feature a high quality embroidered running horse logo on front

Interior

**WE PROUDLY FEATURE AUTHENTIC MUSTANG REPRODUCTIONS FROM SCOTT DRAKE ENTERPRISES!**





mats and a rubber backing with anti-slip spikes. Set includes two front mats and two rear mats.

**Floor Mat from ACC, Embroidered, Mustang Carpet**

64-68 Aqua*	ACC-FM-EMB-AQ
64-68 Bright blue*	ACC-FM-EMB-BB
64-73 Black*	ACC-FM-EMB-BK
64-73 Dark brown*	ACC-FM-EMB-BN
64-73 Bright red*	ACC-FM-EMB-BR
64-73 Dark blue*	ACC-FM-EMB-DB
64-73 Dark green*	ACC-FM-EMB-DG
64-73 Emberglow*	ACC-FM-EMB-EM
64-73 Ginger*	ACC-FM-EMB-GI
64-73 Ivy gold*	ACC-FM-EMB-IG
64-73 Maroon*	ACC-FM-EMB-MR
64-73 Saddle*	ACC-FM-EMB-SA

**PONY FLOOR MATS**



These are exact copies of an original Ford accessory. Molded in colored PVC

these mats also feature spikes on the backside to reduce sliding. Set includes two front and two rear mats.

**Floor Mats, Pony**

64-73 Blue, 4 piece set*	CSZZ-6513086-BL
64-73 Brown, 4 piece set*	CSZZ-6513086-BN
64-73 Dark red, 4 piece set*	CSZZ-6513086-DR
64-73 Red, 4 piece set*	CSZZ-6513086-RD
64-73 Green, 4 piece set	CSZZ-6513086-GR
64-73 Black, 4 piece set*	CSZZ-6513086-BK

**FASTBACK FOLD DOWN SEAT CARPET**



Made from the original 80/20 blended or 100% Nylon carpeting. Cut to fit.

**Fold Down Seat Carpet, Fastback**

65-68 Bright blue, 80/20	FD-65-BB
65-68 Black, 80/20	FD-65-BK
65-68 Black, 100% nylon	FD-65-BK-N
65-68 Dark brown	FD-65-BN
65-68 Bright red, 80/20	FD-65-BR
65-68 Dark blue, 80/20	FD-65-DB
65-68 Dark green, 80/20	FD-65-DG
65-68 Dark saddle, 80/20	FD-65-DS
65-68 Emberglow, 80/20	FD-65-EM
65-68 Ivy gold, 80/20	FD-65-IG
65-68 Nugget gold, 80/20	FD-65-NG
65-68 Saddle, 80/20	FD-65-SA
66-68 Aqua, 80/20	FD-65-AQ
66-68 Maroon, 80/20	FD-65-MR
67-73 Maroon	FD-67-MR
69-70 Black, 100% nylon	FD-69-BK
69-70 Dark blue, 100% nylon	FD-69-DB

**Fold Down Seat Carpet, Fastback**

69-70 Dark green, 100% nylon	FD-69-DG
69-70 Ginger, 100% nylon	FD-69-GI
69-70 Maroon, 100% nylon	FD-69-MR
69-70 Vermillion, 100% nylon	FD-69-VE
71-73 Black, 100% nylon	FD-71-BK
71-73 Blue, 100% nylon	FD-71-BL
71-73 Dark green, 100% nylon	FD-71-DG
71-73 Ginger, 100% nylon	FD-71-GI

**CONSOLE AND OVERHEAD CONSOLE**

**CRUISER CONSOLE**



These consoles are AWESOME! The cruiser console fits perfectly between the front seats and over the gear shifter

(manual or auto). Same quality as the original Humphugger plus two large size cup holders. 2 versions available. Both look similar, but SCL version is designed to fit on top of a factory console. Easily removed for car shows.

**Console, Cruiser**

64-73 Black, without factory console	CC-BK
64-73 Dark blue, without factory console	CC-DB
64-73 Dark red, without factory console	CC-DR
64-73 Light blue, without factory console	CC-LB
64-73 Bright red, without factory console	CC-RD
64-73 Ivy gold, without factory console	CC-IG
64-73 Parchment, without factory console	CC-PR
64-73 White, without factory console	CC-WT
64-67 Black, long, with factory console	SCL-BK
64-67 Dark blue, long, with factory console	SCL-DB
64-67 Light blue, long, with factory console	SCL-LB
64-67 Bright red, long, with factory console	SCL-RD
64-67 Dark red, long, with factory console	SCL-DR

**HUMP HUGGER CONSOLE**



These consoles are designed with quality in mind. All consoles are constructed using automotive grade vinyl and are double

stitched with commercial grade nylon thread, resistant to heat and sun. All hinges are corrosion resistant nickel plated for longevity.

Designed to sit directly on hump.

**Console, Hump Hugger**

64-73 Black	HH-BK
64-73 Dark blue	HH-DB
64-73 Dark red	HH-DR
64-73 Emberglo	HH-EM
64-73 Ginger	HH-GI
64-73 Ivy gold	HH-IG
64-73 Light blue	HH-LB
64-73 Nugget gold	HH-NG
64-73 Palomino	HH-PA
64-73 Parchment	HH-PR
64-73 Bright red	HH-RD
64-73 Saddle	HH-SA
64-73 Turquoise	HH-TQ
64-73 White	HH-WT

**PLUG & CHUG CONSOLE**



The 64-66 Plug & Chug inserts into the dash in place of an ashtray. The 68-73 Plug & Chug goes into the seat belt holder of the center

console.

**Console, Plug & Chug**

64-66 Black	PC-BK
64-66 White	PC-WT
68-69 Black	PC-BK-68
71-73 Black	PC-BK-71

**SADDLE CONSOLE**



Designed to fit over the top of 1964-1967 consoles. All consoles are constructed using automotive grade vinyl and are double

stitched with commercial grade nylon thread, resistant to heat and sun. All hinges are corrosion resistant nickel plated for longevity.

**Console, Saddle**

64-65 Palomino	SC-PA
64-65 Bright red	SC-RD
64-66 Emberglo	SC-EM
64-66 White	SC-WT
64-67 Black	SC-BK
64-67 Dark blue	SC-DB
66-67 Dark red	SC-DR
66-67 Ivy gold	SC-IG
66-67 Light blue	SC-LB
66-67 Parchment	SC-PR
66-67 Turquoise	SC-TQ

**CONSOLE ASH TRAY LID**

Our lid makes replacing those broken lids easy. Features correct texture and color.



Console Ash Tray Lid  
69-70 ..... C9ZZ-6504814

**CONSOLE ASH TRAY RECEPTICLE**

A beautiful reproduction of the ash tray that fits in the back of the center console.



Console Ash Tray Recepticle  
64-66 ..... CSZZ-65048A42-A

**69-70 COMPLETE CONSOLE ASSEMBLY**

This beautiful reproduction includes main housing, both ash trays, cigarette lighter assembly, main top plate, compartment box and rest pad hinge. Arm rest pad and console shift plate are sold separately.  
**Console Assembly, 69-70 Complete**

 69-70  
C9ZZ-6504536

**COMPLETE CONSOLE ASSEMBLY**

Wow! What a nice part, never thought a reproduction would ever be made. Plastic injection black housing just as original, not a substandard fiberglass version. Includes: Radio bezel, all upper brushed chrome plates, ash tray, floor convenience lamp and wiring harness.

**Console Assembly, Complete**

 67: Will also fit 68, but not concurs for 68  
C7ZZ-65045A36-K

 67: Manual, will fit 1968, but not concurs correct  
C7ZZ-65045A36-M

**CONSOLE COMPARTMENT BOX**

This is the compartment box, it includes the chrome trim for cigar lighter.



Console Compartment Box  
69 ..... C9ZZ-6506010

**CONSOLE DOOR SPRING**

Correct springs for console doors. Plated to prevent corrosion.



Console Door Spring  
64-66 ..... CSZZ-6506040/1A

**CONSOLE END CAP**

Pressure die cast zinc with show car quality chrome. Used on air conditioned cars only.  
**Console End Cap**



64-65: Concurs for 64-65, but will also fit 66  
CSZZ-65044D38-



66: Concurs  
C6ZZ-65044D38-A

**CONSOLE FLIP OPEN DOOR**

Beautiful chrome and black flip open console door, comes with door springs. Nice reproduction.

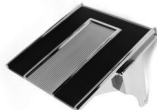

Console Flip Open Door  
65-66 ..... CSZZ-6506024-D

**CONSOLE FRONT PANEL**

The front panel for the glovebox in the console.



Console Front Panel  
65-66 ..... CSZZ-6306021

**CONSOLE HOUSING**

A beautiful reproduction. Ready for your lights and panel. Back side conveniently marked for trimming on convertible and AC applications.  
**Console Housing**



64-66: Black  
CSZZ-65045A36-A

**Console Housing**

 64-66: White  
CSZZ-65045A36-W



69-70: Upper housing, Shelby  
C9ZZ-63044D90-A

**CONSOLE INSERT**

These are complete inserts for our Deluxe Console Plates. Plastic chrome with wood-grain vinyl, ready to install!



**Console Insert**

69 Teak ..... C9ZZ-6504567-CT  
69 Walnut ..... C9ZZ-6504567-CW  
70 Teak ..... D0ZZ-6504567-CT  
70 Walnut ..... D0ZZ-6504567-CW

**CONSOLE INTERNAL HARNESS**

This harness supplies power to the console. Comes from under dash harness and runs underneath carpet, exits at carpet shifter



hole location.

**Console Internal Harness**

64-66 Dash to console ..... CSZZ-13B712-A

**CONSOLE LAMP LENS**

Fits on the rear of the console. Original white plastic color.



**Console Lamp Lens**

64-66 ..... CSZZ-13734-A  
67-68 ..... C7ZZ-13783-A

**CONSOLE MOUNTING BRACKET**

Stamped steel design painted black, made exactly as original. Mounting hardware included.

**Console Mounting Bracket**



64-66: Front  
CSZZ-65045B32



67-68: Overhead, rear, Fastback  
C7ZB-63519B52

Interior

**WE PROUDLY FEATURE AUTHENTIC MUSTANG REPRODUCTIONS FROM SCOTT DRAKE ENTERPRISES!**



**Console Mounting Bracket**



67-68: Overhead, front, Coupe & Fastback  
C7ZB-65519B46-A

**CONSOLE MOUNTING KIT**



Very convenient kit to easily mount your console. Includes all correct screws needed.

**Console Mounting Kit**

64-66 16 pcs. ....CMK-656

**CONSOLE OVERLAY**



**Console Overlay**

64-66 Wood vinyl decal, auto. trans .....  
C5ZZ-6504567-W

67 Aluminum mylar, automatic transmission .....  
C7ZZ-6504567-A

69 Wood vinyl, with seatbelts ....WG-153-V

69-70 Wood vinyl, without seatbelts WG-154-V

**CONSOLE PAD**

Correct urethane molded and textured black vinyl pad. Easy to replace those cracked and worn originals.

**Console Pad**



69 all, 70 Standard  
C9ZZ-6506024-BK



70: Deluxe  
D0ZZ-6506024-BK



71-73: Black only  
D1ZZ-6506024-A

**CONSOLE PAD HINGE**



**Console Pad Hinge**

69-70 ..... C9ZZ-6306050

**CONSOLE REAR LIGHT ASSEMBLY**



Good quality reproduction part, features white plastic lens and pressure die cast body with excellent chrome on

the bezel.

**Console Rear Light Assembly**

65-66 .....C5ZZ-13707-A

67-68 .....C7ZZ-13707-A

**CONSOLE RESTORATION KIT**



Makes restoring a console easy and convenient. Kit includes shift dial, shift slide, console lens with screws and all

hardware necessary to mount console to the floor.

**Console Restoration Kit**

64-66 .....KIT-TRN-3

**CONSOLE ROLL UP DOOR**

Stainless steel flexible slats just like original, chrome plated knob.

**Console Roll Up Door**



67  
C7ZZ-6506024-A



68  
C8ZZ-6506024-A

**CONSOLE SHIFT PLATE**

Nice reproductions of excellent quality.

**Console Shift Plate**



64-66: Automatic transmission, chrome/black  
C5ZZ-7C309-A



64-66: Manual transmission  
C5ZZ-7C309-M



67: Automatic transmission, chrome  
C7ZZ-7C309-A



67: Manual transmission, chrome  
C7ZZ-7C309-M

**Console Shift Plate**



67-68: Automatic transmission, brushed aluminum  
C7ZZ-7D443-P



69: Deluxe, automatic transmission  
C9ZZ-6504567-AD



69: Standard, automatic transmission  
C9ZZ-6504567-AS



69: Deluxe, 4 speed  
C9ZZ-6504567-MD



69: Standard, 4 speed  
C9ZZ-6504567-MS



70: Deluxe, automatic transmission  
D0ZZ-6504567-AD



70: Standard, automatic transmission  
D0ZZ-6504567-AS



70: Deluxe, 4 speed  
D0ZZ-6504567-MD



70: Standard, 4 speed  
D0ZZ-6504567-MS

**CONSOLE TOP PLATE**

Die cast construction, chrome plated and recessed area painted black.



**Console Top Plate**

64-66 ..... C5ZZ-6504567-C

71-73 Finish plate ..... D1ZZ-7C309-A/M

### CONSOLE UPPER PLATE



This is the upper panel that the shifter chrome trim attaches to, comes with the metal retainers.

Console Upper Plate  
69-70 ..... C9ZZ-6304490

### OVERHEAD CONSOLE ASSEMBLY



A beautiful reproduction of a rare option. The console base is made of vinyl and urethane with exact details. We

have installed our maplight switch and light housing with our beautiful chrome bezels. Includes wiring harness and mounting screws. Mounting brackets available separately.

#### Overhead Console Assembly

67	Fastback, black	.....C7ZZ-63519A58BK
67	Fastback, blue	.....C7ZZ-63519A58BL
67	Fastback, ivy gold	.....C7ZZ-63519A58IG
67	Fastback, parchment	.....C7ZZ-63519A58PR
67	Fastback, red	.....C7ZZ-63519A58RD
67	Coupe, black	.....C7ZZ-65519A58BK
67	Coupe, blue	.....C7ZZ-65519A58BL
67	Coupe, ivy gold	.....C7ZZ-65519A58IG
67	Coupe, parchment	.....C7ZZ-65519A58PR
67	Coupe, red	.....C7ZZ-65519A58RD

### OVERHEAD CONSOLE MAP LIGHT



Die-cast construction with a quality chrome finish. Another excellent reproduction. Includes clear lenses.

Overhead Console Map Light  
67-68 .....C7ZZ-13788-A

### OVERHEAD CONSOLE OVERLAY



Wood grain vinyl for the Overhead Console panel

Overhead Console Overlay  
68 Coupe .....WG-151-V  
68 Fastback .....WG-152-V

### OVERHEAD CONSOLE PANEL



Features a stamped aluminum, line-grain finish like the originals. Not a cheap vinyl decal.

Overhead Console Panel  
67 Fastback .....C7ZZ-63519A58AL  
67 Coupe .....C7ZZ-65519A58AL

## DASH

### CLOCK KNOB AND SCREW SET



Our Clock adjusting knob features great detail and a nice chrome finish. The set screw is threaded for the original clock stem.

Clock Knob and Screw Set  
67-68 .....C7ZZ-15032-A

### PLASTIC DASH COVER



Molded plastic dash covers that appear to be an original padded dash. Slips over the original padded dash panel for a nifty cure

for splits and tears. Completely blocks UV light and the drying effects it causes on vinyl covering on padded dashes.

#### Dash Cover, Plastic

64-65	.....	C5ZZ-6504290-DC
66	.....	C6ZZ-6504290-DC
67-68	.....	C7ZZ-6504290-DC
69-70	Without air conditioner	.....
		C9ZZ-6504290-DC
69-70	With air conditioner	..C9ZZ-6504290DCA
71-73	.....	D1ZZ-6504290-DC

### DASH MOLDING CLIP KIT



Dash Molding Clip Kit includes chrome screws and the special spring clips that secure the trim moldings to the dash. 10 pieces

Dash Molding Clip Kit  
64-65 .....C4DZ-6404561-K

### ORIGINAL FORD TOOLING DASH

#### PAD



Scott Drake Mustang and Universal Urethane have gone to great lengths to make their dash pads the best on the market.

They start by using Ford's Original Tooling.

Next they went to Ford's original supplier of vinyl for exact grain and texture. These dash pads are the finest available and easiest to install.

#### Dash Pad, Original Ford Tooling

65	Black	.....	C5ZZ-6504290-BK
64-65	Blue	.....	C5ZZ-6504290-BL
65	Bright red	.....	C5ZZ-6504290-BR
64-65	Neutral	.....	C5ZZ-6504290-NL
66	Black	.....	C6ZZ-6504290-BK
66	Blue	.....	C6ZZ-6504290-BL
66	Bright red, special order	.....	C6ZZ-6504290-BR
66	Dark red	.....	C6ZZ-6504290-DR
66	Neutral	.....	C6ZZ-6504290-NL
69-70	Black, without air conditioner	.....	C9ZZ-6504282AIA
69-70	Black, with air conditioner	.....	C9ZZ-6504282BIA
69-70	Neutral, with air conditioner	.....	C9ZZ-6504282WAC
69-70	Neutral, without air conditioner	.....	C9ZZ-6504282WNA
71-73	Black	.....	D1ZZ-6504290-BK
71-73	Blue	.....	D1ZZ-6504290-BL
71-73	Ginger	.....	D1ZZ-6504290-GI

### REPRODUCTION DASH PAD



A nice reproduction at a lower price. Not made from original Ford tooling.

#### Dash Pad, Reproduction

64-65	Black	.....	C5ZZ-6504290BKR
64-65	Blue	.....	C5ZZ-6504290BLR
64-65	Red	.....	C5ZZ-6504290BRR
66	Black	.....	C6ZZ-6504290BKR
66	Blue	.....	C6ZZ-6504290BLR
66	Dark red	.....	C6ZZ-6504290DRR
67-68	Aqua	.....	C7ZZ-6504290-AQ
67-68	Black	.....	C7ZZ-6504290-BK
67-68	Blue	.....	C7ZZ-6504290-BL
67-68	Ivy gold	.....	C7ZZ-6504290-IG
67-68	Red	.....	C7ZZ-6504290-RD
71-73	Black	.....	D1ZZ-6504290BKR
71-73	Blue	.....	D1ZZ-6504290BLR
71-73	Ginger	.....	D1ZZ-6504290GIR

## DELUXE DASH PANEL

Our deluxe dash panels are quality injection molded plastic, chrome plated. Available without inserts so you can add your own, or with inserts already installed! Our aluminum inserts are real brushed aluminum, and our woodgrain inserts are vinyl with metal backing to prevent shrinking. For Deluxe interiors.

### Dash Panel, Deluxe



67: 3 piece set with aluminum inserts  
C7Z-6504410-KR



67: Upper with aluminum insert  
C7Z-65044A90AR



67-68: Lower without insert  
C7Z-65044A10-C



67-68: Upper without insert  
C7Z-65044A90-A



67-68: Center without insert  
C7Z-6504774-A



67-68: 3 piece set trim w/o inserts  
C7Z-6504410-WO



68: 3 piece set with metal backed woodgrain inserts  
C8Z-6504410-KR



68: With metal backed woodgrain inserts, for cars with air conditioning  
C8Z-6504410-AC

## DASH PANEL HEATER CONTROL PLATE INSERT

Real brushed aluminum inserts, or vinyl woodgrain with metal backing inserts. These are perfect matches to our other dash panel inserts.

### Dash Panel Heater Control Plate Insert



67: Brushed Aluminum w/out AC  
C7Z-6504410-HC

### Dash Panel Heater Control Plate Insert



68: Metal backed woodgrain w/out AC  
C8Z-6504410-HC

## DASH PANEL INSERT

These vinyl inserts are made to be installed on dash and instrument panel. Vinyl versions are adhesive backed. Clear silicone adhesive is recommended for metal backed.

### Dash Panel Insert



68: Metal-backed woodgrain, 4 piece set, w/out AC  
WG-102-M



68: Vinyl woodgrain, 7 piece set, w/ or w/out AC  
WG-128-V



68: Vinyl woodgrain, 9 piece set, w/ or w/out AC  
WG-129-V

## DASH PANEL AC VENT INSERT

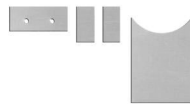

Our brushed aluminum inserts match our other 67 Deluxe panels. Includes 4 pieces. Does not include adhesive.

### Dash Panel AC Vent Insert

67 .....C7Z-6504410-AC

## STANDARD DASH PANEL

Our standard dash panels are quality injection molded plastic, chrome plated and then screened black. For standard interiors.

### Dash Panel, Standard



67-68: 3 piece set  
C7Z-6504410-K



67-68: Lower  
C7Z-65044A10-D



67-68: Upper  
C7Z-65044A90-B

### Dash Panel, Standard



67-68: Center  
C7Z-6504774-B

## DASH PANEL ASSEMBLY



Complete metal stamped dash assembly.  
\*Will fit 66

with minor modification for speedometer.

### Dash Panel Assembly

64-65\* .....C5Z-6504320-A

67-68 .....C7Z-6504320-A

69 with AC.....C9Z-6504320-AC

## DASH PANEL BEZEL



This is the section above the glove box door.

### Dash Panel Bezel

71-73 Black, right hand ..... D1ZZ-10838-RH

## DASH PANEL EMBLEM



### Dash Panel Emblem



67: Shelby GT350 grille, dash or deck<sup>®</sup>  
S7MS-16098-C



67: Shelby GT500 grille, dash or deck<sup>®</sup>  
S7MS-16098-D



67-68: Running horse, red & silver, very small 7/8"X3/8", adhesive backed\*  
C7Z-65044A90-E



67-68: Running horse tribar emblem with base, for Deluxe interior\*  
C7Z-65044A90EP



67-68: Running horse tribar emblem without base, for Deluxe interior\*  
C7Z-65044A90-M

**Dash Panel Emblem**



67-68: Running horse base only, for Deluxe interior  
C7Z-65044A90-P



68: GT 500\*  
S8MS-6304460-C



68: GT 350\*  
S8MS-6304460-D



68: Cobra Jet\*  
S8MS-6304460-E



69-70: Outer chrome bezel only  
C9Z-6304460



69-70: Mach 1\*  
C9Z-6304460-A



69-70: Mach 1, insert only  
C9Z-6304460-AI



69-70: Mustang script  
C9Z-6304460-B



69-70: Mustang, insert only  
C9Z-6304460-BI



69-70: Grande, insert only  
C9Z-6304460-GI



69-70: Cobra GT 350\*  
S9MS-6304460-A



69-70: Cobra Jet GT 500\*  
S9MS-6304460-B

**Dash Panel Emblem**



71-73: Mustang script, except Grande\*  
D1Z-6504774-EM

**DASH PANEL REPAIR PLATE**



For that hacked radio installation, this panel provides a new dashboard section for installation of a stock radio and an original

look. Can be welded into position. Designed to fit under dash pad.

**Dash Panel Repair Plate**

65-66 .....C5Z-6504360-PP

**DASH PANEL TRIM**



ABS trim pieces that mount on outboard sides of dash near the kick panels.

**Dash Panel Trim**

69-70 Trim molding ..... C9Z-6504718

**LOWER INSTRUMENT PANEL PAD**



Molded in urethane and made with exact detail of the original. Available in assorted colors.

**Lower Instrument Panel Pad**

67-68 Black ..... C7Z-6504292-BK  
67-68 Blue ..... C7Z-6504292-BL  
67-68 Ivy Gold ..... C7Z-6504292-IG  
67-68 Parchment ..... C7Z-6504292-PR  
67-68 Red ..... C7Z-6504292-RD  
67-68 Aqua/turquoise ..... C7Z-6504292-TQ

**PARKING BRAKE HANDLE**

High quality injection molded parts, mounting lock pin and allen set screw included. Excellent detail in a reproduction part. Black plastic. New improved metal insert. Thicker than original.

**Parking Brake Handle**



64-66  
CODZ-2760-B



65-68: Billet  
B-2760-BL

**Parking Brake Handle**



67-68  
C7Z-2760-B

**CENTER DASH RADIO MOLDING**



ABS trim pieces for each side of the radio.

**Radio Molding, Center Dash**

69-70 ..... C9Z-6504472/3

**DOOR SILLS**

**LIGHTED SILL PLATE**

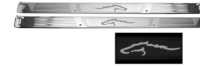

These sill plates are constructed of 304 stainless steel, not lightweight aluminum. We also gave it a bright, polished finish,

and added brushed GT type stripes for a retro look that will keep it looking great for years. Additionally featured is a custom logo with a cool blue luminescent light that glows when the doors are opened. In daylight or at night, our lighted sill plates will turn heads. Simple installation makes this a "must have" part for your Mustang.

**Sill Plate, Lighted**

64-68 Coupe/fastback, blue C5Z-6513208-HL  
64-68 Convertible, blue ..... C5Z-7613208-HL  
69-70 All, blue ..... C9Z-6513208-HL

**ORIGINAL FORD TOOLING SILL PLATE**



Made by original Ford supplier. Concours quality. Perfect fit. Heavy gauge aluminum. Emblem not included.

**Sill Plate, Original Ford Tooling**

64-68 Coupe/fastback ..... C5Z-6513208-BP  
64-68 Convertible ..... C5Z-7613208

**REPRODUCTION SILL PLATE**



New improved stampings, which are thicker than previous reproductions. These new stampings are stronger and stiffer.

Polished aluminum. Emblem not included.

**Sill Plate, Reproduction**

64-68 Coupe/fastback ..... C5Z-6513208-B  
64-68 Convertible ..... C5Z-7613208-C  
69-70 All ..... C9Z-6513208-A

Interior

**WE PROUDLY FEATURE AUTHENTIC MUSTANG REPRODUCTIONS FROM SCOTT DRAKE ENTERPRISES!**



**Sill Plate, Reproduction**

71-73 All .....D1ZZ-6513208-A

**STAINLESS STEEL SILL PLATE**

A Scott Drake exclusive! These plates are stamped to look like original scuff plates but feature highly-polished stainless

steel. These are heavy-gauge scuff plates and will not dent or scratch like other aluminum versions. Our plates also feature slotted mounting holes for quick and easy installation.

**Sill Plate, Stainless Steel**

64-68 Convertible .....C5ZZ-7613208-SS

65-68 Coupe/fastback .....C5ZZ-6513208-SS

**STAINLESS STEEL ACCESSORY SILL PLATE**

A Ford accessory designed to protect paint on rocker. Stainless steel construction.

**Sill Plate, Stainless Steel Accessory**

64-68 Coupe/Fastback .....C5ZZ-6513242-A

69-70 All .....C9ZZ-6513242-A

**SILL PLATE EMBLEM**

This is the aluminum emblem which mounts on the center of all scuff plates. Features raised script like original, adhesive backed and protective coating.

**Sill Plate Emblem**64-66: Black, Ford logo\*  
C5ZZ-6513208-65-66: Shelby®  
S1MS-6513208-T67-73: Blue, Ford logo\*  
C7ZZ-6513208-T68-73: Blue, Ford logo\*  
C8ZZ-6513208-T**SILL PLATE SCREW**

Oval head chrome plated screws.

**Sill Plate Screw**

64-68 Set of 18 .....376290-SK

64-70 Bulk .....376290-S

**DOORS****ARM REST BASE**

Precision molded of stress-resistant plastic, with a smooth durable chrome finish.

**Arm Rest Base**

64-66 .....C5ZZ-6524144-A

**ARM REST BASE AND PAD KIT**

Each kit contains a pair of arm rest pads and bases. Arm rest pads feature correct texture and molded in color. Steel insert



for strength. Extra thick vinyl skin. Base is precision molded of stress resistant plastic with a smooth chrome finish. Kit includes all mounting hardware.

**Arm Rest Base and Pad Kit**

64-65 Bright red .....KIT-INT-2-BR

64-65 White .....KIT-INT-2-WT

64-66 Black .....KIT-INT-2-BK

64-66 Medium blue .....KIT-INT-2-BL

66 Dark blue .....KIT-INT-2-DB

66 Dark red .....KIT-INT-2-DR

**1964-66 ARM REST PAD**

Correct texture and molded-in colors, with steel insert molded into foam to increase strength. Extra thick vinyl skins. American

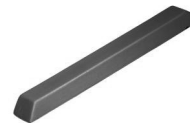

made.

**Arm Rest Pad, 1964-66**

64-66 Black .....C5ZZ-6524100-BK

66 Aqua .....C5ZZ-6524100-AQ

64-65 Medium blue .....C5ZZ-6524100-BL

64-65 Bright red .....C5ZZ-6524100-BR

66 Dark blue .....C5ZZ-6524100-DB

66 Dark red .....C5ZZ-6524100-DR

64-66 Ivy gold .....C5ZZ-6524100-IG

**Arm Rest Pad, 1964-66**

64-65 Palomino .....C5ZZ-6524100-PA

66 Parchment .....C5ZZ-6524100-PR

64-65 White .....C5ZZ-6524100-WT

**1967 ARM REST PAD**

Correct texture and molded-in colors, with steel insert molded into foam to increase strength. Extra thick vinyl skins. American



made.

**Arm Rest Pad, 1967**

67 Black .....C7ZZ-6524100-BK

67 Aqua .....C7ZZ-6524100-AQ

67 Blue .....C7ZZ-6524100-BL

67 Ivy gold .....C7ZZ-6524100-IG

67 Parchment .....C7ZZ-6524100-PR

67 Red .....C7ZZ-6524100-RD

67 Saddle .....C7ZZ-6524100-SA

**1968 ARM REST PAD**

Correct texture and molded-in colors, with steel insert molded into foam to increase strength. Extra thick vinyl skins. American



made.

**Arm Rest Pad, 1968**

68 Black, right hand .....C8ZZ-6524100-BK

68 Black, left hand .....C8ZZ-6524101-BK

68 Aqua, right hand .....C8ZZ-6524100-AQ

68 Aqua, left hand .....C8ZZ-6524101-AQ

68 Blue, right hand .....C8ZZ-6524100-BL

68 Blue, left hand .....C8ZZ-6524101-BL

68 Ivy gold, right hand ... C8ZZ-6524100-IG

68 Ivy gold, left hand .... C8ZZ-6524101-IG

68 Parchment, right hand .....C8ZZ-6524100-PR

68 Parchment, left hand C8ZZ-6524101-PR

68 Red, right hand .....C8ZZ-6524100-RD

68 Red, left hand .....C8ZZ-6524101-RD

68 Saddle, right hand .....C8ZZ-6524100-SA

68 Saddle, left hand .....C8ZZ-6524101-SA

**1968 DELUXE ARM REST PAD**

Correct texture and molded-in colors, with steel insert molded into foam to increase strength. Extra thick vinyl skins. American



made.

**Arm Rest Pad, 1968 Deluxe**

68 Black, right hand .....C8ZZ-6524100BKD

68 Black, left hand .....C8ZZ-6524101BKD

68 Aqua, right hand .....C8ZZ-6524100AQD

68 Aqua, left hand .....C8ZZ-6524101AQD

68 Blue, right hand .....C8ZZ-6524100BLD

**Arm Rest Pad, 1968 Deluxe**

- 68 Blue, left hand ..... C8ZZ-6524101BLD
- 68 Ivy gold, right hand ... C8ZZ-6524100IGD
- 68 Ivy gold, left hand .... C8ZZ-6524101IGD
- 68 Maroon, right hand . C8ZZ-6524100MRD
- 68 Maroon, left hand ... C8ZZ-6524101MRD
- 68 Parchment, right hand .....
- C8ZZ-6524100PRD
- 68 Parchment, left hand C8ZZ-6524101PRD
- 68 Saddle, right hand .... C8ZZ-6524100SAD
- 68 Saddle, left hand ..... C8ZZ-6524101SAD

**1969-70 ARM REST PAD**

Correct texture and molded-in colors, with steel insert molded into foam to increase strength. Extra thick vinyl skins. American

made. Note: Ford used 2 different arm rest pads in 69-70. We currently offer only 1 version. Mounting holes are approximately 12 1/4" from center to center on our pads. Some cars measured approximately 13". These cars will require relocating one mounting hole before door panel is installed. We are working with manufacturer to offer both versions in the future.

**Arm Rest Pad, 1969-70**

- 69-70 Black, right hand ..... C9ZZ-6524100-BK
- 69-70 Black, left hand ..... C9ZZ-6524101-BK
- 69-70 White, right hand ..... C9ZZ-6524100-WT
- 69-70 White, left hand ..... C9ZZ-6524101-WT

**1971-73 ARM REST PAD**

Correct texture and molded-in colors, with steel insert molded into foam to increase strength. Extra thick vinyl skins. American

made.

**Arm Rest Pad, 1971-73**

- 71-73 Black, right hand ..... D1ZZ-6524100-BK
- 71-73 Black, left hand ..... D1ZZ-6524101-BK
- 71-73 Blue, right hand ..... D1ZZ-6524100-BL
- 71-73 Blue, left hand ..... D1ZZ-6524101-BL
- 71-73 Ginger, right hand ..... D1ZZ-6524100-GI
- 71-73 Ginger, left hand ..... D1ZZ-6524101-GI

**ARM REST PAD BASE****Arm Rest Pad Base**

- 71-73 Standard interior ..... D1AZ-5724144-A

**ARM REST PLUG**

Perfect detail in these often missing plugs.

**Arm Rest Plug**

- 67 Black, deluxe ..... C7ZZ-6524056-BK
- 67 Parchment, deluxe ... C7ZZ-6524056-PR
- 68 Black, deluxe, set of 4 C8ZZ-6524056-BK
- 68 Parchment, deluxe, set of 4 .....
- C8ZZ-6524056-PR

**DOOR COURTESY LIGHT ASSEMBLY**

These assemblies feature bright white lenses, beautiful chrome plating, correct wiring and housing. Mounting hardware included. These are the best on the market.

**Door Courtesy Light Assembly**

- 65-66: Deluxe
- C5Z-13786



- 67-68: Deluxe
- C7ZB-13A744-C



- 69-70: Deluxe, set of 2
- C9WY-13776/7-A

**DOOR COURTESY LIGHT LENS**

Replace those yellowed lenses with our clean white reproduction. Sold in matching pairs.

**Door Courtesy Light Lens**

- 67-68 Deluxe ..... C7ZZ-13731-B

**DELUXE DOOR ESCUTCHEONS**

Die cast and chrome plated. New improved design is very wear resistant. Also included are nylon bushings to prevent scratches.

**Door Escutcheons, Deluxe**

- 65-66 Chrome ..... C4SY-6322620/1A
- 65-66 Satin ..... C4SY-6322620/1S

**INSIDE DOOR HANDLE**

Excellent reproductions of the originals, fit is perfect. All of these handles feature a brightly polished, chrome finish.

**Door Handle, Inside**

- 64-65: Early 65, right hand or left hand
- C3AZ-6222600-B



- 65-67: Late 65, right hand or left hand
- C5ZZ-6522600-C



- 65-66: Deluxe, right hand
- C5ZZ-6522600-A



- 65-66: Deluxe, left hand
- C5ZZ-6522601-A



- 67: Deluxe, right hand or left hand
- C7ZZ-6522600-A



- 68: Right hand
- C7AZ-5422600-B



- 68: Left hand
- C7AZ-5422601-B



- 69-70: Right hand
- C9AZ-6222600-A



- 69-70: Left hand
- C9AZ-6222601-A



- 71-73: Deluxe, right hand
- D1ZZ-6522600-A



- 71-73: Deluxe, left hand
- D1ZZ-6522601-A



- 65-66: Deluxe, leather with satin finish, pair
- C5ZZ-65226001LS

Interior

**WE PROUDLY FEATURE AUTHENTIC MUSTANG REPRODUCTIONS FROM SCOTT DRAKE ENTERPRISES!**





**Door Handle, Inside**



65-66: Deluxe, leather, pair  
C5Z-6522600/1L



65-66: Deluxe, wood with satin finish, pair  
C5Z-65226001WS

**DOOR HANDLE & WINDOW CRANK KIT**

**KIT**



Kit includes clip or screw-on door handles, window cranks, quarter window cranks (for coupe and

convertible), clips/screws and backing plates.

**Door Handle & Window Crank Kit**

- 64-65 Early 65 coupe or convertible, chrome ...  
KIT-DH-2
- 65 Early 65 fastback, chrome .....KIT-DH-1
- 65-67 Late 65 fastback, chrome .....KIT-DH-3
- 65-67 Late 65 fastback, satin .....KIT-DH-3S
- 65-67 Late 65 coupe or convertible, chrome ....  
KIT-DH-4
- 65-67 Late 65 coupe or convertible, satin .....  
KIT-DH-4S
- 68 Fastback, chrome .....KIT-DH-7
- 68 Coupe or convertible, chrome ..KIT-DH-8

**DOOR HANDLE BEZEL**

Trim behind door handle.



**Door Handle Bezel**

69-70 Deluxe interior ..... C9Z-6522634-D

**DOOR INNER UPPER TRIM**



**Door Inner Upper Trim**

69-70 Standard interior, Right hand .....  
C9Z-6520904-A

**Door Inner Upper Trim**

69-70 Standard interior, left hand .....  
C9Z-6520905-A

**DOOR LOCK KNOB**

Made by Plastic injection. Sold as a pair. Available in black, chrome, or satin chrome.  
**Door Lock Knob**



64-66: Chrome  
C5DZ-6221850-A



64-66: Satin chrome  
C5DZ-6221850-S



67: Chrome  
C5AZ-6221850-A



68-73: Chrome  
C8AZ-6221850-A

**1964-65 DOOR PANEL**



Our door panels are upholstered with the original material, mounted on precision die-cut fiberboard. Colors and textures

are identical to the originals. Includes chrome plated plastic trim where appropriate.

**Door Panel, 1964-65**

- 64-65 Black .....C5Z-65239423BK
- 64-65 Blue .....C5Z-65239423BL
- 64-65 Ivy gold .....C5Z-65239423IG
- 64-65 Palamino .....C5Z-65239423PA
- 64-65 Red .....C5Z-65239423RD
- 64-65 White .....C5Z-65239423WT

**1965-66 DELUXE DOOR PANEL**



These panels are the finest available. Excellent molded vinyl surface with the correct grain. Foam filled on

treated pressboard. These door panels DO NOT include stainless steel trim pieces, or aluminum inserts.

**Door Panel, 1965-66 Deluxe**

- 65 Bright red .....C5Z65239423RDP
- 65-66 Black .....C5Z65239423BKP
- 65-66 White .....C5Z65239423WTP
- 66 Dark red .....C5Z65239423DRP

**Door Panel, 1965-66 Deluxe**

66 Parchment .....C5Z65239423PRP

**1966 DOOR PANEL**



Our door panels are upholstered with the original material, mounted on precision die-cut fiberboard.

Colors and textures

are identical to the originals. Includes chrome plated plastic trim where appropriate.

**Door Panel, 1966**

- 66 Black .....C6Z-65239423BK
- 66 Aqua .....C6Z-65239423AQ
- 66 Blue .....C6Z-65239423BL
- 66 Dark red .....C6Z-65239423DR
- 66 Parchment .....C6Z-65239423PR

**1967 DOOR PANEL**



Our door panels are upholstered with the original material, mounted on precision die-cut fiberboard. Colors and textures

are identical to the originals. Includes chrome plated plastic trim where appropriate.

**Door Panel, 1967**

- 67 Black .....C7Z-65239423BK
- 67 Aqua .....C7Z-65239423AQ
- 67 Blue .....C7Z-65239423BL
- 67 Ivy gold .....C7Z-65239423IG
- 67 Parchment .....C7Z-65239423PR
- 67 Red .....C7Z-65239423RD
- 67 Saddle .....C7Z-65239423SA

**1967 DELUXE DOOR PANEL**



These panels are the finest available. Excellent molded vinyl surface with the correct grain. Foam filled on treated

pressboard. These door panels do not include stainless steel trim pieces, or aluminum inserts.

**Door Panel, 1967 Deluxe**

- 67 Black .....C7Z65239423BKD
- 67 Blue .....C7Z65239423BLD
- 67 Ivy gold .....C7Z65239423IGD
- 67 Parchment .....C7Z65239423PRD
- 67 Red .....C7Z65239423RDD

**1968 DOOR PANEL**

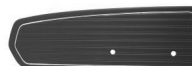

Our door panels are upholstered with the original material, mounted on precision die-cut fiberboard. Colors and textures

are identical to the originals. Includes chrome

plated plastic trim where appropriate.

**Door Panel, 1968**

68	Black	C8ZZ-65239423BK
68	Blue	C8ZZ-65239423BL
68	Ivy gold	C8ZZ-65239423IG
68	Maroon	C8ZZ-65239423MR
68	Nugget gold	C8ZZ-65239423NG
68	Parchment	C8ZZ-65239423PR
68	Saddle	C8ZZ-65239423SA

**1968 DELUXE DOOR PANEL**

These panels are the finest available. Excellent molded vinyl surface with the correct grain. Foam filled on treated



pressboard. These door panels do not include stainless steel trim pieces, or aluminum inserts.

**Door Panel, 1968 Deluxe**

68	Black	C8ZZ65239423BKD
68	Aqua	C8ZZ65239423AQD
68	Blue	C8ZZ65239423BLD
68	Ivy gold	C8ZZ65239423IGD
68	Maroon	C8ZZ65239423MRD
68	Nugget gold	C8ZZ65239423NGD
68	Parchment	C8ZZ65239423PRD
68	Saddle	C8ZZ65239423SAD

**1969 DOOR PANEL**

Our door panels are upholstered with the original material, mounted on precision die-cut fiberboard. Colors and textures



are identical to the originals. Includes chrome plated plastic trim where appropriate.

**Door Panel, 1969**

69	Black	C9ZZ-65239423BK
69	Dark ivy gold	C9ZZ-65239423DI
69	Dark red	C9ZZ-65239423DR
69	Light blue	C9ZZ-65239423LB
69	Nugget gold	C9ZZ-65239423NG
69	White	C9ZZ-65239423WT

**1969-70 DELUXE DOOR PANEL**

These panels are the finest available. Excellent molded vinyl surface with the correct grain. Foam filled on treated



pressboard. These door panels do not include stainless steel trim pieces, or aluminum inserts. Some cutting may be required.

**Door Panel, 1969-70 Deluxe**

69	Black with black carpet	C9ZZ65239423BKD
69	Dark red with maroon carpet	C9ZZ65239423DRD

**Door Panel, 1969-70 Deluxe**

69	White with black carpet	C9ZZ65239423WTD
70	Medium blue with blue carpet	C9ZZ65239423BLD
70	Black with black carpet	D0ZZ65239423BKD
70	Ginger with dark brown carpet	D0ZZ65239423GID
70	White with black carpet	D0ZZ65239423WTD

**1970 DOOR PANEL**

Our door panels are upholstered with the original material, mounted on precision die-cut fiberboard. Colors and textures



are identical to the originals. Includes chrome plated plastic trim where appropriate.

**Door Panel, 1970**

70	Black	D0ZZ-65239423BK
70	Blue	D0ZZ-65239423BL
70	Bright red	D0ZZ-65239423BR
70	Ivy gold	D0ZZ-65239423IG
70	White	D0ZZ-65239423WT

**1971-73 DOOR PANEL**

Our door panels are upholstered with the original material, mounted on precision die-cut fiberboard. Colors and textures



are identical to the originals. Includes chrome plated plastic trim where appropriate.

**Door Panel, 1971-73**

71-73	Black	D1ZZ-65239423BK
71-73	Blue	D1ZZ-65239423BL
71-73	Bright red	D1ZZ-65239423BR
71-73	Ginger	D1ZZ-65239423GI
71-73	Green	D1ZZ-65239423GR
71-73	Ivy gold	D1ZZ-65239423IG
71-73	White	D1ZZ-65239423WT

**1971-73 DELUXE DOOR PANEL**

These panels are the finest available. Excellent molded vinyl surface with the correct grain. Foam filled on treated



pressboard. These door panels do not include stainless steel trim pieces, or aluminum inserts.

**Door Panel, 1971-73 Deluxe**

71-73	Black	D1ZZ65239423BKD
71-73	Medium blue	D1ZZ65239423BLD
71-73	Ginger	D1ZZ65239423GID
71-73	White	D1ZZ65239423WTD

**2-TONE DOOR PANEL**



Made with tough Masonite backing instead of cardboard for extra durability and easy installation. Two-tone panels are

available in a variety of color combinations.

**Door Panel, 2-Tone**

65	Blue/white	C5ZZ65239423B/W
65	Black/white	C5ZZ65239423BK/W
65	Ivy gold/white	C5ZZ65239423I/W
65	Palamino/white	C5ZZ65239423P/W
65	Bright red/white	C6ZZ65239423R/W
66	Aqua/white	C6ZZ65239423A/W
66	Blue/white	C6ZZ65239423B/W
66	Black/white	C6ZZ65239423BK/W
66	Parchment/white	C6ZZ65239423P/W
66	Dark red/white	C6ZZ65239423R/W
67	Aqua/white	C7ZZ65239423A/W
67	Blue/white	C7ZZ65239423B/W
67	Black/white	C7ZZ65239423BK/W
67	Ivy gold/white	C7ZZ65239423I/W
67	Parchment/white	C7ZZ65239423P/W
67	Dark red/white	C7ZZ65239423R/W
67	Saddle/white	C7ZZ65239423S/W

**DOOR PANEL CLIP**



High quality door panel clips in bulk or nicely packaged in a set of 30.

**Door Panel Clip**

64-70	Standard, set of 30, also fits 68 Deluxe	380552-K
64-70	Standard, bulk, also fits 68 Deluxe	380552-S
65-67	Deluxe, set of 30	375553-K
65-67	Deluxe, bulk	375553-S
65-67	Deluxe screws and clips	375553-69D

**DOOR PANEL CUP**



Plastic injection molded black with vacuum chrome plated trim, includes mounting hardware.

**Door Panel Cup**

69-70	Standard interior	C9ZZ-65226A34
	1969-70 Deluxe Door Handle Trim in black.	



**Door Panel Kit, Deluxe**

69-70		C9ZZ-6522634-D
-------	--	----------------

Interior

**WE PROUDLY FEATURE AUTHENTIC MUSTANG REPRODUCTIONS FROM SCOTT DRAKE ENTERPRISES!**



### DELUXE DOOR PANEL CUP



'64-'66 version

64-66: Feature perfect fit and color match. Ours are double dipped in textured vinyl just like originals. 69-70: New pressure

die cast zinc construction just like the originals, but stronger.

#### Door Panel Cup, Deluxe

64-66 Black	.....	C5ZZ-6524142-BK
64-66 Bright red	.....	C5ZZ-6524142-BR
64-66 Dark red	.....	C5ZZ-6524142-DR
64-66 Parchment	.....	C5ZZ-6524142-PR
64-66 White	.....	C5ZZ-6524142-WT
69 Black, pair	.....	C9ZZ6524046/7BK
69 White, pair	.....	C9ZZ6524046/7WT
69 White, right hand	.....	C9ZZ-6524046-WT
69 Black, left hand	.....	C9ZZ-6524047-BK
69 White, left hand	.....	C9ZZ-6524047-WT
70 Black, pair	.....	D0ZZ-6524046/7B
70 White, pair	.....	D0ZZ-6524046/7W

### DELUXE DOOR PANEL CUP BRACKET



This support bracket is used to fasten the Pony door cups the inner door on 1965-67 Deluxe interiors. Takes two of these per car.

#### Door Panel Cup Bracket, Deluxe

65-67	.....	C5ZZ-6524140
1969	.....	C9ZZ-65240A10-A
1970	.....	D0ZZ-65240A10-B

### DOOR PANEL CUP PAD



Textured rubber pad that covers the door cup mounting screws. Correct color match.

#### Door Panel Cup Pad

65-66 White	.....	C5SZ-6324046-WT
65-66 Black	.....	C5SZ-6324046-BK
66-67 Parchment	.....	C5SZ-6324046-PR
1969 Black	.....	C9ZZ-6524046-BK
1970 Black	.....	D0ZZ-6524046-BK

### DOOR PANEL INSERT

These deluxe door panel inserts are made of high quality brushed aluminum or vinyl woodgrain.

#### Door Panel Insert



67: Brushed aluminum with correct polished raised bead & mounting spikes  
C7ZZ-65237A22/3

#### Door Panel Insert



67: Brushed aluminum with correct polished raised bead & mounting spikes w/out remote mirror hole  
C7ZZ-65237A223N



69-70: Walnut  
C9Z-65237A22-A



69-70: Teak  
C9Z-65237A22-T

### DOOR PANEL INSERT WITH ALUMINUM PANEL

We have produced these panels from our own tooling with exact detailing right down to the black painted border. Included is a pair of high quality, adhesive backed, woodgrain vinyl inserts, available in dark walnut or light teak. Don't forget about our beautiful mustang emblems to finish off these panels.

#### Door Panel Insert with Aluminum Panel

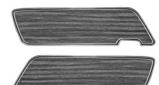

69-70: Teak inserts  
C9ZZ-6523942/3T



69-70: Walnut inserts  
C9ZZ-6523942/3W E

### DELUXE DOOR PANEL KIT



Kit includes pads, cups, brackets and mounting hardware for mounting cups.

#### Door Panel Kit, Deluxe

65-66 Black	.....	KIT-INT5-BK
65-66 White	.....	KIT-INT5-WT
69-70 Black	.....	375553-69D

### DELUXE DOOR PANEL TRIM

Made by Scott Drake, these Deluxe Door Panel Moldings are constructed of Stainless Steel. They feature all the exact detail of the original and are designed to fit new-reproduction

deluxe panels. Sold in pairs.

#### Door Panel Trim, Deluxe

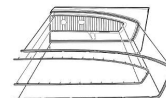

65-66: Right hand  
C5ZZ-652042/70

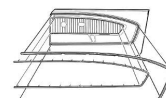

65-66: Left hand  
C5ZZ-652043/71

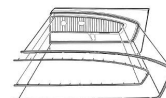

65-66: Left hand and right hand  
C5ZZ-652042/71S



67: Left hand and right hand, outer only  
C7ZZ-6520970/1



69-70: Mustang Deluxe Mach/SS Door Trim  
C9ZZ-6520970/1

### DOOR PANEL U-CUP



This Plastic formed cup is used for the inside door handle pocket, not included with reproduction door panels.

#### Door Panel U-Cup

67 Deluxe Interior, Black	.....	C7ZZ-6524148-BK
67 Deluxe Interior, Parchment	.....	C7ZZ-6524148-PR

### DOOR PULL



Exact reproduction of the originals. Exact detail of stitches and grain pattern.

#### Door Pull

68 Aqua, pair	.....	C8ZZ-6526656-AQ
68 Black, pair	.....	C8ZZ-6526656-BK
68 Dark blue, pair	.....	C8ZZ-6526656-BL
68 Maroon, pair	.....	C8ZZ-6526656-MR
68 Parchment, pair	.....	C8ZZ-6526656-PR
68 Saddle, pair	.....	C8ZZ-6526656-SA
71-73 Black, left hand	.....	D1ZZ-6526655-BK
71-73 Blue, left hand	.....	D1ZZ-6526655-BL
71-73 Ginger, left hand	.....	D1ZZ-6526655-GI
71-73 Black, right hand	.....	D1ZZ-6526656-BK
71-73 Blue, right hand	.....	D1ZZ-6526656-BL
71-73 Ginger, right hand	.....	D1ZZ-6526656-GI

### INNER DOOR PULL BRACE



Exact reproduction. Includes mounting hardware and nylon inserts. Painted black.

**Door Pull Brace, Inner**  
68 Deluxe interior .....C8AZ-6522606-A

### DOOR PULL END CAP KIT

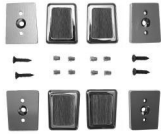

Our door pull end caps feature beautiful chrome and wood grain insert that matches the dash and door panel wood

grain. We feel these look a lot nicer than the original. All mounting hardware included. Inner door braces sold separately.

**Door Pull End Cap Kit**  
68 Deluxe interior .....C7WY-6522670/6

### WOODGRAIN DOOR PULL INSERTS



These are the same inserts that are available in our complete door pull end cap kit, but now available on their own.

Quickly and easily replace worn or missing inserts. Sold as a set of 4 inserts.

**Door Pull Inserts, Woodgrain**  
68 Set of 4 .....C7WY-6522670-A

### DOOR SPEAKER GRILLE

A nice reproduction speaker grill. Features correct screen pattern and edge molding. Includes hardware.

**Door Speaker Grille**



65-66  
C6ZZ-18798-A



67-68: Deluxe, also fits 65-66 doors for a custom look, use C7ZN-3301 for proper installation  
C7ZZ-6520956/7A



69-70: Stereo script  
C9ZZ-18798-A



71-73  
D2ZZ-18978-A

### DOOR WATERSHIELD



Protects door panels and upholstery from water damage. Specially treated paper, precisely die-cut for an easy installation. **These**

**are exact copies of the originals. We will be offering a Deluxe version that offers insulation and sound deadening properties. Available Summer 2012. When ordering, just add "D" to the end of the part numbers listed below to order the Deluxe versions.**

<b>Door Watershield</b>	
64-66 Coupe .....	C5ZZ-65-WS
64-66 Convertible .....	C5ZZ-76-WS
65-66 Fastback .....	C5ZZ-63-WS
67-68 Fastback .....	C7ZZ-63-WS
67-68 Coupe .....	C7ZZ-65-WS
67-68 Convertible .....	C7ZZ-76-WS
69-70 Fastback .....	C9ZZ-63-WS
69-70 Coupe .....	C9ZZ-65-WS
69-70 Convertible .....	C9ZZ-76-WS
71-73 Fastback .....	D1ZZ-63-WS
71-73 Coupe .....	D1ZZ-65-WS
71-73 Convertible .....	D1ZZ-76-WS

### WINDOW CRANK



Highly detailed die-cast zinc construction. Finished in beautiful chrome. Much better detail than others.

**Window Crank**

64-65 Early 65, chrome .....	C4SZ-6323342-A
65-67 Late 65, chrome .....	C5ZZ-6523342-C
68-70 Chrome .....	C8AZ-6223342-A
71-72 Chrome, w/out knob .....	C9UZ-8223342

### QUARTER WINDOW CRANK

Quarter window crank handle, made by Scott Drake. Like all our handles, these feature better detail and better chrome than competitors.

**Window Crank, Quarter**



64-65: Early 65, chrome  
C4SZ-6530322-A



65-67: Late 65, chrome  
C5ZZ-6530322-A



68-70: Chrome  
C8Z-6530322-A

### WINDOW CRANK HANDLE COVER PLATE



#### PLATE

This is a aluminum disc that covers the window crank handle screw hole. Stamped aluminum with circular brushed finish

and adhesive backed.

**Window Crank Handle Cover Plate**

68-73 .....C8AZ-6223362-A

### WINDOW CRANK KNOB



A premium reproduction. The knob is vinyl-molded and has a plastic insert just like the original. Mounting pin and

wave washer are also included.

**Window Crank Knob**

68-70 Clear/Silver .....	C8AZ-6223352-CL
68-70 Ivy gold .....	C8AZ-6223352-IG
68-70 Maroon .....	C8AZ-6223352-MR
68-73 Black .....	C8AZ-6223352-BK
68-73 Blue .....	C8AZ-6223352-BL
68-73 Ginger .....	C8AZ-6223352-GI
68-73 Green .....	C8AZ-6223352-GR
68-73 Parchment and nugget gold .....	C8AZ-6223352-PR
68-73 Vermillion .....	C8AZ-6223352-VE
68-73 White .....	C8AZ-6223352-WT

## FASTBACK

### FASTBACK FOLD DOWN SEAT

#### LATCH



Complete latch includes main body, chrome sliding latch, chrome knob and rubber bumper.

**Fold Down Seat Latch, Fastback**

65 Right hand .....	C5ZZ-6361382-A
66 Left hand .....	C6ZZ-6361382-A
67-70 Right hand .....	C7ZZ-6361382-A
67-70 Left hand .....	C7ZZ-6361383-A

### FASTBACK FOLD DOWN SEAT

#### MOLDING

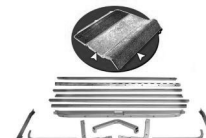

Stamped steel construction and chrome plated. Complete kit which includes hinge.

**Fold Down Seat Molding, Fastback**

65-68 .....	C5ZZ-63130A18-K
69-70 .....	C9ZZ-63130A18-K

**WE PROUDLY FEATURE AUTHENTIC MUSTANG REPRODUCTIONS FROM SCOTT DRAKE ENTERPRISES!**



## **FASTBACK INTERIOR QUARTER**

### **TRIM**

These are just like originals.  
Quarter Trim, Fastback Interior



67-68: Full set  
C7Z6331144/83K .....

## **FASTBACK REAR SEAT GUIDE**



Black injection molded plastic just like the originals. This part is a fast seller, as most originals are damaged or missing.

Rear Seat Guide, Fastback  
65-66 ..... C5Z-63613B28-B

## **FASTBACK REAR SEAT HARDWARE**



Kit includes all rests, bumpers and guides for a complete job. Ten pieces in each kit.

Rear Seat Hardware, Fastback  
65 Early ..... C5Z-6360575-K  
65-66 ..... C6Z-6360575-K

## **FASTBACK REAR SEAT LATCH COVER PLATE**



Textured like originals.  
Paint to match.

Rear Seat Latch Cover Plate, Fastback  
65 ..... C5Z-63613B26-A  
66 ..... C6Z-63613B26-A  
67-68 Fixed rear seat ..... C7Z-63613B26/7  
67-68 Fold-down, right hand .....  
C7Z-63613B26-A  
67-68 Fold-down, left hand C7Z-63613B27-A

## **FASTBACK REAR SEAT LATCH KNOB**

We offer these 100% correct copies of the original parts for the discriminating Mustang owner. Made from machined steel, then heavily chrome plated.

Rear Seat Latch Knob, Fastback



65-66  
C5Z-6362418-B

Rear Seat Latch Knob, Fastback



67-70  
C7Z-6362418-B

## **FASTBACK REAR SEAT SUPPORT**

Chrome plated heavy gauge steel. Supports seat when raised.

Rear Seat Support, Fastback



65  
C5Z-6360575-A



65-70  
C6Z-6360575-A

## **FASTBACK REAR TRIM CENTER CAP**



Stamped steel trim cap used to attach narrow fastback interior moldings.

Rear Trim Center Cap, Fastback  
65-66 ..... C5Z-63291C12-A

## **REAR TRIM PANEL, FASTBACK**

This part is commonly sun damaged. Also, required when converting over to a fold-down car.

Rear Trim Panel, Fastback



67-68: 5 piece set  
C7Z-63311123-K



69-70: Upper  
C9Z-6331111/2B



69-70: Side panels  
C9Z-633112/3-A



69-70: Middle upper  
C9Z-63424A68-A

## **REAR SPORT DECK BRACKET**

The brackets that secure the rear section of the sport deck to the car.



Sport Deck Bracket, Rear  
65-70 ..... C5Z-63424A78-A

## **FASTBACK TRAP DOOR**



This fastback trap door panel is made of original gauge sheet metal and finished with the correct embossed texture.

Painted satin black.  
Trap Door, Fastback  
65-66 ..... C5Z-6345728-A  
67-68 ..... M3661  
69-70 ..... C9Z-6345728-A

## **FASTBACK TRAP DOOR HINGE**



Exact detail of the original hinges. Painted black. Ready to install.

Trap Door Hinge, Fastback  
65-66 Pair ..... C5Z-6345702-A  
67-70 ..... C7Z-6345702

## **FASTBACK TRAP DOOR LATCH**



Hold trap door in place. Galvanized to prevent rust.

Trap Door Latch, Fastback  
65-68 ..... C5Z-6345704-A  
69-70 ..... C7Z-6345704-A

## **FASTBACK TRAP DOOR LATCH CATCH**



The catch to secure the trap door latch.

Trap Door Latch Catch, Fastback  
65-70 ..... C5Z-63605A44-A

**TRAP DOOR PROP ASSEMBLY**



Trap Door Prop Assembly  
65-66 Assembly ..... C5ZZ-6345734-A

**TRAP DOOR PROP ROD**

This part allows you to easily prop open the trap door and hold it in the open position.

Trap Door Prop Rod



67-68  
C7Z-6345734-A



69-70  
C9Z-6345734-A

**UPPER PANEL JOINT COVER**

Painted black and pre-stamped with mounting hole. An exact fit.



Upper Panel Joint Cover  
65-66 Fastback ..... C5ZZ-6342353-A

**UPPER REAR TRIM PANEL BRACKETS**

These brackets are required when adding a fold-down seat option to a non fold-down car. Mounting screws not included.

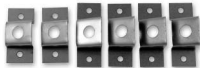

Upper Rear Trim Panel Brackets  
69-70 ..... C7SZ-6342468-B

**FASTBACK INTERIOR VENT GRILL**

This hot new product is made from ABS plastic so you will never have to worry about the pocking associated with the

originals. They are beautifully chrome plated with the recessed areas painted black to look like the originals. Cleverly designed to install with small screws from the backside, for simple installation. Sold as a pair with

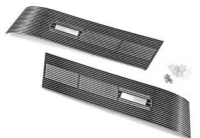

mounting screws included.

Vent Grill, Fastback Interior  
67-68 ..... C7Z-6331067-VG

**FASTBACK VENT SLIDE**

A beautiful reproduction of a commonly pitted part. Our slides are made of zinc die-cast, and finished with highly polished chrome. Mounting hardware included.

Vent Slide, Fastback



65-66  
C5Z-63278C20/1



67-68  
C7Z-63278C48/9

**FASTBACK VENT SLIDE BEZEL**

Beautifully chromed stamped steel bezels to replace those nasty originals.



Vent Slide Bezel, Fastback  
65-66 ..... C5Z-6331002/3

**FASTBACK VENTED QUARTER PANEL TRIM**

A beautiful reproduction, these panels are black ABS plastic with shiny chrome grilles for inner quarter trim.



Vented Quarter Panel Trim, Fastback  
67-68 Black ..... C7Z-63310A06/7

**GLOVE BOX**

**GLOVE BOX**

1964-1966 & 1971-1973 Precision die cut black chipboard construction just as originals. 1967-1968 Plastic injection.



- Glove Box
- 64-66 Black, chipboard with lens ..... C5Z-6506010-A
  - 64-66 Black, flocked ..... C5Z-6506010-FB
  - 64-66 Gray, flocked ..... C5Z-6506010-FG
  - 66 Black, chipboard, concours w/ clip & hole for flasher ..... C6Z-6506010-A
  - 67-68 Black, plastic ..... C7Z-6506010-A
  - 69-70 w/ AC ..... C9Z-6506010-AC
  - 69-70 w/out AC ..... C9Z-6506010-B

**Glove Box**

- 71-73 Black, chipboard, without air conditioner  
D1ZZ-6506010-A
- 71-73 Black, chipboard, with air conditioner ....  
D1ZZ-6506010-B

**GLOVE BOX BUTTON BEZEL**

Commonly missing. Made of stainless steel.



Glove Box Button Bezel  
67-72 ..... C60B-62060A12

**GLOVE BOX DECAL**

This decal came installed on the inside of the glove box door and charted the tire information.



Glove Box Decal  
66 \* ..... DF-19  
67-68 \* ..... DF-282

**GLOVE BOX DOOR**

Excellent reproductions, pressure die cast zinc with show car chrome & a correct horse emblem. These are chromed much better than others. Ours are also the only ones with the correct swedging of the horse & correct woodgrain color.

C5ZZ-6506024-A  
64-65: Standard, black, w/ emblem



C5ZZ-6506024-AE  
64-65: Standard, black, w/out emblem

C5ZZ-6506024-B  
65: GT, standard, black, w/ emblem



C5ZZ-6506024-BE  
65: GT, standard, black, w/out emblem

C5ZZ-6506024-C  
65-66: Deluxe, metal-backed woodgrain, w/ emblem



C5ZZ-6506024-CE  
65-66: Deluxe, woodgrain, w/out emblem

Interior

**WE PROUDLY FEATURE AUTHENTIC MUSTANG REPRODUCTIONS FROM SCOTT DRAKE ENTERPRISES!**



### **GLOVE BOX DOOR (CONTINUED)**



C6ZZ-6506024-A  
66: Standard, black, w/ emblem

C6ZZ-6506024-AE  
66: Standard, black, w/out emblem



C7ZZ-6506024-B  
67-68

### **GLOVE BOX DOOR CABLE**



Cable with correct ends and mounting screws. Supports glove box door when opened.

**Glove Box Door Cable**  
65-66 ..... CSZZ-65060A08-A

### **GLOVE BOX DOOR INSERTS**



A nice wood applique to replace that worn, cracked or faded surface on 1965 and 1966 Pony glove box doors. See our

Instrument Panel section, later in this catalog, for matching instrument panel inserts.

**Glove Box Door Inserts**  
65-66 Woodgrain, metal backed .....  
CSZZ-65060A24

65-66 Woodgrain, vinyl ..... WG-125-V

### **GLOVE BOX EMBLEM**



Pressure die cast, excellent reproductions. Perfect chrome, stripes are painted correct

colors.  
**Glove Box Emblem**  
64-65 Running horse, curved\* .....  
C4ZB-65060A14-A

65-66 Running horse, flat\* .. CSZB-65060A14-A

### **GLOVE BOX LAMP**



Correct wire pigtail. Bulb included. New improved tooling.

**Glove Box Lamp**  
64-68 ..... CSZZ-14413-A

### **GLOVE BOX LATCH**



A great optional accessory from Scott Drake. All new tooling was created to produce our glovebox latches. Also available

as a locking version with keys.

**Glove Box Latch**  
64-65 Standard, curved glove box door .....  
CSZZ-6506072-A

65-66 Deluxe, flat glove box door .....  
CSZZ-6506072-B

67-68 Standard ..... C6DZ-6506072-A

69-70 Standard ..... C9Z-6506072-A

### **GLOVE BOX LOCK**



A great optional accessory from Scott Drake. All new tooling was created to produce our glovebox latches. Includes 2

matching keys.

**Glove Box Lock**  
64-65 Standard, curved door CSZZ-6506072-AL  
65-66 Deluxe, flat door ..... CSZZ-6506072-BL  
67-68 Standard ..... C6DZ-6506072-AL  
69-70 Standard ..... C9Z-6506072-AL

### **GLOVE BOX OR TRUNK LOCK SET**



New from Scott Drake. All new tooling was created to produce our glovebox latches. This kit allows use of the same key for both the

glovebox and trunk lock.

**Glove Box or Trunk Lock Set**  
67-68 ..... C6DZ-6506072-K  
69-70 ..... C9Z-6506072-K

### **GLOVE BOX SCREW KIT**



Correct broad head screws with black finish.

**Glove Box Screw Kit**  
64-66 ..... 382086-SK

### **GLOVE BOX STRIKER SET**



Exact reproduction of the original. Hardware included.

**Glove Box Striker Set**  
64-66 Zinc ..... CSZZ-6506064-A

### **Glove Box Striker Set**

64-66 Chrome ..... CSZZ-6506064-C

## **HEADLINERS**

### **COUPE HEADLINER**

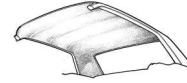

Scott Drake now produces some of the best headliners on the market. Formerly available under the Classic Auto Trim

label, our headliners have been preferred by professional installers for years. Manufactured with pride in the U.S. with the most correct fabric available. Precision cut from time tested patterns for a perfect fit. Don't forget new sunvisors to complete the look.

#### **Headliner, Coupe**

64-70 Aqua ..... HL-FM-CP-65-AQ

64-70 Black ..... HL-FM-CP-65-BK

64-70 Medium blue ..... HL-FM-CP-65-BL

64-70 Dark blue ..... HL-FM-CP-65-DB

64-70 Dark green ..... HL-FM-CP-65-DG

64-70 Dark red ..... HL-FM-CP-65-DR

64-70 Medium ivy gold ..... HL-FM-CP-65-IG

64-70 Light blue ..... HL-FM-CP-65-LB

64-70 Maroon ..... HL-FM-CP-65-MR

64-70 Parchment ..... HL-FM-CP-65-PR

64-70 Red ..... HL-FM-CP-65-RD

64-70 Saddle ..... HL-FM-CP-65-SA

64-70 Vermillion ..... HL-FM-CP-65-VE

64-70 White ..... HL-FM-CP-65-WT

71-73 Black ..... HL-FM-CP-71-BK

71-73 Dark blue ..... HL-FM-CP-71-DB

71-73 Dark green ..... HL-FM-CP-71-DG

71-73 Dark red ..... HL-FM-CP-71-DR

71-73 Ginger ..... HL-FM-CP-71-GI

71-73 Light blue ..... HL-FM-CP-71-LB

71-73 Medium blue ..... HL-FM-CP-71-MB

71-73 Parchment ..... HL-FM-CP-71-PR

71-73 Red ..... HL-FM-CP-71-RD

71-73 Saddle ..... HL-FM-CP-71-SA

71-73 White ..... HL-FM-CP-71-WT

### **FASTBACK HEADLINER**



Scott Drake now produces some of the best headliners on the market. Formerly available under the Classic Auto Trim

label, our headliners have been preferred by professional installers for years. Manufactured with pride in the U.S. with the most correct fabric available. Precision cut from time tested patterns for a perfect fit. Don't forget new sunvisors to complete the look.

#### **Headliner, Fastback**

65-68 Aqua ..... HL-FM-FB-65-AQ

### Headliner, Fastback

65-68	Black	HL-FM-FB-65-BK
65-68	Medium blue	HL-FM-FB-65-BL
65-68	Dark aqua	HL-FM-FB-65-DA
65-68	Dark green	HL-FM-FB-65-DG
65-68	Dark red	HL-FM-FB-65-DR
65-68	Medium ivy gold	HL-FM-FB-65-IG
65-68	Light blue	HL-FM-FB-65-LB
65-68	Medium blue	HL-FM-FB-65-MB
65-68	Maroon	HL-FM-FB-65-MR
65-68	Parchment	HL-FM-FB-65-PR
65-68	Bright red	HL-FM-FB-65-RD
65-68	Saddle	HL-FM-FB-65-SA
65-68	Tan	HL-FM-FB-65-TA
65-68	White	HL-FM-FB-65-WT
69-70	Black	HL-FM-FB-69-BK
69-70	Medium blue	HL-FM-FB-69-BL
69-70	Dark blue	HL-FM-FB-69-DB
69-70	Dark green	HL-FM-FB-69-DG
69-70	Dark red	HL-FM-FB-69-DR
69-70	Ivy gold	HL-FM-FB-69-IG
69-70	Light blue	HL-FM-FB-69-LB
69-70	Medium blue	HL-FM-FB-69-MB
69-70	Maroon	HL-FM-FB-69-MR
69-70	Parchment	HL-FM-FB-69-PR
69-70	Red	HL-FM-FB-69-RD
69-70	Saddle	HL-FM-FB-69-SA
69-70	White	HL-FM-FB-69-WT
71-73	Black	HL-FM-FB-71-BK
71-73	Dark blue	HL-FM-FB-71-DB
71-73	Dark green	HL-FM-FB-71-DG
71-73	Ginger	HL-FM-FB-71-GI
71-73	Light blue	HL-FM-FB-71-LB
71-73	Medium blue	HL-FM-FB-71-MB
71-73	Maroon	HL-FM-FB-71-MR
71-73	Red	HL-FM-FB-71-RD
71-73	Saddle	HL-FM-FB-71-SA
71-73	Tan	HL-FM-FB-71-TA
71-73	White	HL-FM-FB-71-WT

### FASTBACK HEADLINER BOW

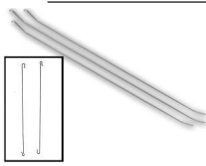

#### Headliner Bow, Fastback

67-68 5 pieces ..... C7Z-6352101-K

### HEADLINER GLUE



This high strength glue comes in an easy to use 4 ounce container with brush applicator built into lid.

#### Headliner Glue

64-73 .....HLG-1829

### HEADLINER INSULATION PAD

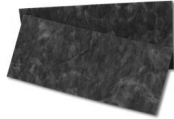

Help insulate interior from both temperature and sound.

#### Headliner Insulation Pad

64-68 Coupe ..... HL-CP-PAD  
64-68 Fastback ..... HL-FB-PAD

### FRONT HEADLINER MOLDING

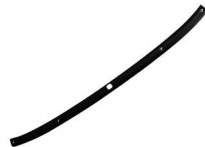

This trim molding is used where the headliner meets the front windshield. Fits both Coupes and Fastbacks. Painted

Black.

#### Headliner Molding, Front

69-70 ..... C9Z-6503606

### HEADLINER PILLAR TRIM SET



These commonly missing pieces are now available. Painted black. Mounting screws included.

#### Headliner Pillar Trim Set

64-68 ..... C5Z-6552136/7

### HEADLINER ROD RETAINER



Commonly missing or bent out of shape. A must for correct headliner installation. Attaches to rear bow.

#### Headliner Rod Retainer

64-68 Coupe .....COAB-6542180-K

### HEADLINER TRIM SIDE PANEL



Precision die-cut construction black chipboard. Covered with matching headliner material.

#### Headliner Trim Side Panel

69-70 No cover, panel only ...C9Z-6352018-9P  
69-70 Black, moonskin .....C9Z-63520189BK  
69-70 Medium blue, moonskin .....C9Z-63520189BL

69-70 Dark green, moonskin .....C9Z-63520189DG  
69 Dark red, moonskin ..C9Z-63520189DR

69-70 Light blue, moonskin C9Z-63520189LB  
69-70 White, moonskin ....C9Z-63520189WT  
71-73 No cover, panel only .. D1ZZ-6352018/9P  
71-73 Black, tier grain .....D1ZZ-63520189BK  
71-73 Blue, tier grain .....D1ZZ-63520189BL

### Headliner Trim Side Panel

71-73 Dark green, tier grain D1ZZ-63520189DG  
71-73 Ginger, tier grain ..... D1ZZ-63520189GI  
71-73 Maroon, tier grain ...D1ZZ-63520189MR  
71-73 Red, tier grain ..... D1ZZ-63520189RD  
71-73 White, tier grain .....D1ZZ-63520189WT

### PILLAR MOLDING



New reproductions of a commonly damaged part. Mounting hardware included. Ready to install.

#### Pillar Molding

69-70 Fastback, black .....C9Z-6303598/9B  
69-70 Fastback, white ..... C9Z-6303598/9W  
69-70 Coupe, black .....C9Z-6503598/9B  
69-70 Convertible, black .....C9Z-7603598/9B

### PILLAR POST PAD



Molded in high-grade urethane, these parts are exactly like the originals.

#### Pillar Post Pad

67-68 Right hand ..... C7Z-6503598-AQ  
67-68 Black, right hand ..... C7Z-6503598-BK  
67-68 Blue, right hand .....C7Z-6503598-BL  
67-68 Ivy gold, right hand ... C7Z-6503598-IG  
67-68 Parchment, right hand .....C7Z-6503598-PR

67-68 Red, right hand ..... C7Z-6503598-RD  
67-68 Left hand ..... C7Z-6503599-AQ  
67-68 Black, left hand ..... C7Z-6503599-BK  
67-68 Blue, left hand .....C7Z-6503599-BL  
67-68 Ivy gold, left hand .... C7Z-6503599-IG  
67-68 Parchment, left hand C7Z-6503599-PR  
67-68 Red, left hand ..... C7Z-6503599-RD

### INSTRUMENT PANEL & GAUGES

### CLOCK



Excellent reproduction made by Scott Drake. Originals rarely work, easily installs into cars that did not have a clock originally.

#### Clock

67-68 Quartz movement ..... C7AZ-15000-A

Interior

**WE PROUDLY FEATURE AUTHENTIC MUSTANG REPRODUCTIONS FROM SCOTT DRAKE ENTERPRISES!**





### CLOCK LENS



Deluxe clock lens with pointer.

**Clock Lens**  
69-70 Deluxe, w/ pointer .....C9ZF-15000

### AMPERAGE GAUGE



These high quality gauges are manufactured with UV coating to protect the

silk screened printing from fading. Gauges are exact reproductions complete with the Ford part number and logos. All gauges are pre-tested for accuracy. (Will not fit 65)

#### Gauge, Amperage

66 \* .....C5ZF-10671  
69 Black .....C9ZF-10671-A  
70 Gray .....D0ZF-10671-A

### FUEL GAUGE



These high quality gauges are manufactured with UV coating to protect the silk screened printing from fading. Gauges are exact reproductions complete with the Ford part number and logos. All gauges are pre-tested for accuracy.

#### Gauge, Fuel



64-65: Standard\*  
C5DF-9306



65-66: GT\*  
C5ZF-9306



69: Black\*  
C9ZF-9280



70: Gray\*  
D0ZF-9280

### OIL PRESSURE GAUGE



These high quality gauges are manufactured with UV coating to protect the silk screened printing from fading. Gauges are exact reproductions complete with the Ford part number and

logos. All gauges are pre-tested for accuracy.

#### Gauge, Oil Pressure



65-66 \*  
C5ZF-9B309



69: Black  
C9ZF-9B309-A



70: Gray  
D0ZF-9B309-A

### SPEEDOMETER GAUGE



This high quality speedometer gauge is an exact reproduction of the original, complete with correct

Ford part number and logo. The silk screened print is UV protected for longer life and fade resistance. All gauges are pre-tested for accuracy.

#### Gauge, Speedometer



64-65: Standard\*  
C5DF-17266



65-66: 65 GT - 66 All\*  
C5ZF-17265



69: Standard, without tach\*  
C9ZF-17265



69-70: 69: Deluxe and Mach 1, 70:  
All; Without tach  
D0ZF-17265

### TACHOMETER GAUGE

The classic hood mounted tach from the 60's. Black plastic housing with a black dial face and back lit numbers makes this a great add-on accessory. Feature a red-line needle. Holes must be drilled in the hood for proper installation.

#### Gauge, Tachometer



65-70: Black face, 8000 RPM  
C8AZ-17A326-B

#### Gauge, Tachometer



65-70: White face, 8000 RPM  
C8AZ-17A326-W

### TEMPERATURE GAUGE



These high quality gauges are manufactured with UV coating to protect the silk screened printing

from fading. Gauges are exact reproductions complete with the Ford part number and logos. All gauges are pre-tested for accuracy.

#### Gauge, Temperature



64-65: Standard\*  
C5DF-10971



65-66: 65 GT - 66 All\*  
C5ZF-10971



69: Black, w/o tach\*  
C9ZF-10B966



70: Gray, w/o tach\*  
D0ZF-10B966

### GAUGE, FUEL-TEMP



Exact reproduction of factory gauge.



#### Gauge, Fuel-Temp

69 Black\* .....C9ZF-9A284  
70 Gray\* .....D0ZF-9A284

### GAUGE, SPEEDOMETER OVERLAY



#### Gauge, Speedometer Overlay

64-65 Overlay .....C5DZ-10890-KM

**INSTRUMENT BEZEL**

Our bezel are the best, they feature details that other simply don't have. Chrome is superior and all fit accurately.  
Instrument Bezel

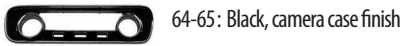

64-65: Black, camera case finish



65: GT, Black



65-66: Pony, with vinyl woodgrain insert  
C5Z-10838-B



65-66: Pony, with woodgrain insert (metal backed)  
C5Z-10838-BMI



66: Black  
C6Z-10838-A



67: Deluxe, brushed aluminum  
C7Z-10838-B



67: Camera Case Black  
C7Z-10838-C



68: Camera Case Black  
C8Z-10838-A



68: Deluxe, with woodgrain insert (economy)  
C8Z-10838-B



68: Deluxe, with woodgrain insert (metal backed)  
C8Z-10838-BMI



69: Black, camera case finish  
C9Z-10838-A

**Instrument Bezel**



70: Black, camera case finish  
D0Z-10838-A



71-73: Black  
D1Z-10838-A

**INSTRUMENT BEZEL MOUNTING SET**

These are the screws that attach the instrument cluster bezel to the dash.

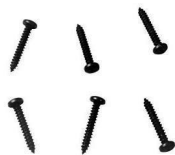

**Instrument Bezel Mounting Set**

64-66 ..... C5Z-10848-MK

**INSTRUMENT BEZEL TOP RETAINING CLIPS**



Very hard to find, unique top retaining clips for 64-66 Mustang instrument bezels. Top 4 are very special clips, commonly missing.

Set of 6.  
Instrument Bezel Top Retaining Clips  
64-66 ..... 379130-5

**INSTRUMENT LENS**

Optical grade injection molded plastic.  
Instrument Lens



64: Generator style  
C4DZ-10887-A



65: Alternator style  
C5Z-10887-A



65-66: Full instrumentation  
C5Z-10887-B



67-68: Speedometer, oil, alternator  
C7Z-10887-A



67-68: 5 piece set  
C7Z-10887-A/C

**Instrument Lens**

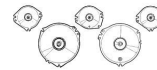

67-68: 5 piece set, with tachometer  
C7Z-10887-A/D

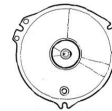

67-68: Speedometer, with tachometer  
C7Z-10887-B



67-68: Fuel, temperature  
C7Z-10887-C



67-68: Center, with hole for clock option  
C7Z-10887-D



69-70: Set, without tachometer  
C9Z-10887-A



69-70: Set, with tachometer  
C9Z-10887-T



71-73: Without tachometer  
D1Z-10887-AR

**INSTRUMENT LENS ANTI-RATTLE PAD**

This simple little kit takes care of those rattles between the instrument lens and the bezel. Insert in front of instrument

lenses.  
Instrument Lens Anti-Rattle Pad  
64-65 10 piece set ..... C4DZ-10856  
66 13 piece set ..... C6DZ-10856

**INSTRUMENT LENS RETAINER BEZEL**

These painted black bezels retain the lenses to the instrument bezel. Works on tach and non-tach vehicles, and cars with optional clock.  
Instrument Lens Retainer Bezel  
67-68 ..... C7Z-10890-LRK



Interior

**WE PROUDLY FEATURE AUTHENTIC MUSTANG REPRODUCTIONS FROM SCOTT DRAKE ENTERPRISES!**



### INSTRUMENT PANEL AND GLOVE BOX



This kit will really make your interior stand out. We have taken our beautiful reproduction 65 GT instrument panel and flat glove

box door and added brushed aluminum inserts. The glove box door comes without the horse emblem for a clean look. This also allows you to add the emblem of your choice. Brushed aluminum panels are also available as a set without the instrument panel or door.  
**Instrument Panel and Glove Box**  
 65-66 .....KIT-INT-AL

### INSTRUMENT PANEL AND GLOVE BOX INSERT

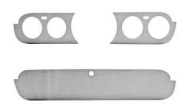

These fit our 65 GT instrument panel and our flat glove box door.

**Instrument Panel and Glove Box Insert**  
 65-66 Aluminum .....KIT-INT-ALMI  
 65-66 Woodgrain .....WG-126-V

### INSTRUMENT PANEL INSERT



These are metal backed wood grained panels. Under extreme heat these will not peel like competitors. Las Vegas summer tested.

See our Glove Box section, earlier in this category, for matching glove box inserts.  
**Instrument Panel Insert**  
 65-66 Woodgrain .....C5ZZ-10838-WMI

### INSTRUMENT PANEL LED LIGHTS

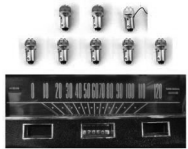

Finally see your gauges at night with cool-running, lifetime LED's. 4x brighter than old incandescent lights! Each kit is warranted

for the life of your car, and includes gauge illumination lights (blue), turn signal indicator lights (white), and high-beam light (white/red). These kits use your existing gauges – you just replace the bulbs! Lifetime warranty!  
**Instrument Panel LED Lights**

- 64-66 Long Speedometer .....SD-6456-GA-BL
- 65-66 5-Gauge Cluster .....SD-66-GA-BL
- 67-68 .....SD-6768-GA-BL
- 69-70 .....SD-6970-GA-BL
- 71-73 .....SD-7173-GA-BL
- 64-68 White 1895, set of 4 .....SD-1895
- 64-68 Blue 1895, set of 4 .....SD-1895-BL

### INSTRUMENT PANEL LIGHT FILTER



Add new brightness to your instrument gauge panel. They look great on stock panels or with our white-face panel inserts. Set of 8. Re-use

existing screws.  
**Instrument Panel Light Filter**  
 67-70 Blue - original .....C4VY-10B870-B-8  
 67-70 Red .....C4VY-10B870-R-8  
 67-70 Amber/yellow .....C4VY-10B870-Y-8

### INSTRUMENT PANEL LIGHT FILTER KIT







Add new brightness to your instrument gauge panel. They look great on stock panels or with our white-face panel inserts. 4 Filter set with

mounting screws.  
**Instrument Panel Light Filter Kit**  
 64-66 Blue - original .....C4VY-10B870-B-4  
 64-66 Red .....C4VY-10B870-R-4  
 64-66 Amber/yellow .....C4VY-10B870-Y-4



### ELECTRO LUMINESCENT INSTRUMENT PANEL SET

A Scott Drake exclusive. Our panels actually glow! Light intensity can be changed with a dedicated controller. Color can be changed from soft blue to soft green with the push of a button. Instrument bezel and actual gauges are not included.

**Instrument Panel Set, Electro Luminescent**

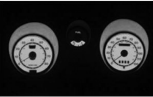

-  64-65: 3 piece  
C5ZZ-10890-GLO
-  66: 5 piece  
C6ZZ-10890-GLO
-  67-68: 11 piece, no tach  
C7ZZ-10890-GLO
-  67-68: 6 piece, 6000 RPM  
C7ZZ-17360-GLO6
-  67-68: 6 piece, 8000 rpm  
C7ZZ-17360-GLO8

### Instrument Panel Set, Electro Luminescent

-  69-70: 6 piece, no tachometer  
C9ZZ-10890-GLO
-  71-73: 5 piece  
D1ZZ-10890-GLO
-  71-73: With tachometer  
D1ZZ-10890-TGLO

### WHITE FACE INSTRUMENT PANEL SET

These inexpensive kits are perfect for the resto-mod or anyone looking for a more modern look. These kits are installed onto your original black faced gauges with double sided tape. All numbers, letters and markings are copied exactly as original. Perfectly die cut to ease installation. Instrument bezel and actual gauges are not included.  
**Instrument Panel Set, White Face**

-  64-65: 3 piece  
C5ZZ-10890-W
-  65-66: 5 piece  
C6ZZ-10890-W
-  67-68: 11 piece, without tach  
C7ZZ-10890-W

### TRIP RESET BUTTON ASSEMBLY



A wonderful reproduction of a very hard to find part. Designed for easy installation and adjustment.

**Trip Reset Button Assembly**  
 67-68 .....C7ZZ-17A381-B

## KICK PANEL

### PONY KICK PANEL CARPET



Made by ACC. Matches the 80/20 blend carpets. Mounts to the lower half of kick panel.

#### Kick Panel Carpet, Pony

65-66	Convertible, bright blue	.....	KPC-CNV-BB
65-66	Convertible, black	.....	KPC-CNV-BK
65-66	Convertible, dark blue	.....	KPC-CNV-DB
65-66	Convertible, dark green	.....	KPC-CNV-DG
65-66	Convertible, emberglow	...	KPC-CNV-EM
65-66	Convertible, ivy gold	.....	KPC-CNV-IG
65-66	Convertible, maroon	.....	KPC-CNV-MR
65-66	Convertible, red	.....	KPC-CNV-RD
65-66	Convertible, saddle	.....	KPC-CNV-SA
65-66	Convertible, turquoise	.....	KPC-CNV-TQ
65-66	Coupe/fastback, dark green	.....	KPC-CP/FB-DG
65-66	Coupe/fastback, bright blue	.....	KPC-CPFB-BB
65-66	Coupe/fastback, black	.....	KPC-CPFB-BK
65-66	Coupe/fastback, dark blue	.....	KPC-CPFB-DB
65-66	Coupe/fastback, emberglow	.....	KPC-CPFB-EM
65-66	Coupe/fastback, ivy gold	....	KPC-CPFB-IG
65-66	Coupe/fastback, moss green	.....	KPC-CPFB-MG
65-66	Coupe/fastback, maroon	..	KPC-CPFB-MR
65-66	Coupe/fastback, red	.....	KPC-CPFB-RD
65-66	Coupe/fastback, saddle	....	KPC-CPFB-SA
65-66	Coupe/fastback, turquoise	.....	KPC-CPFB-TQ

### KICK PANEL TRIM



Excellent reproductions, made from rust proof 304 stainless steel with a cadmium plated liner. Packaged in pairs.

#### Kick Panel Trim

65-66	.....	C5ZZ-65023445SS
-------	-------	-----------------

### 64-68 KICK PANELS



Molded Now made by Drake! These Kick Panels feature Scott Drake's top-of-the-line attention to detail, and are available at a lower price than before! Features include factory hole locations\*, correct flaired edge to accommodate windlace, and concurs correct thickness and texture. Perfect fit allows easy install.

\*Note: Factory hole locations for 64-66 version are correct

for Late 65-66. Earlier Mustangs had one additional hole.

64-66	Coupe/fastback, black	.....	C5ZZ-65023445BK
64-66	Convertible, black	.....	C5ZZ-76023445BK
67-68	Coupe/fastback, black	.....	C7ZZ-65023445BK
67-68	Convertible, black	.....	C7ZZ-76023445BK
<b>*Note: The below colored Kick Panel are not made from Drake Tooling and do not offer the same features. A few of the more popular colors will be available late 2012 from Drake Tooling. Some colors will not be available from Drake Tooling.</b>			
64-65	Coupe/fastback, medium blue	.....	C5ZZ-65023445BL
64-65	Coupe/fastback, bright red	.....	C5ZZ-65023445BR
64-65	Coupe/fastback, ivy gold	.....	C5ZZ-65023445IG
64-65	Coupe/fastback, palomino	.....	C5ZZ-65023445PA
64-65	Coupe/fastback, white	.....	C5ZZ-65023445WT
64-65	Convertible, blue	.....	C5ZZ-76023445BL
64-65	Convertible, bright red	.....	C5ZZ-76023445BR
64-65	Convertible, ivy gold	..	C5ZZ-76023445IG
64-65	Convertible, palomino	.....	C5ZZ-76023445PA
64-66	Convertible, white	...	C5ZZ-76023445WT
66	Coupe/fastback, aqua	.....	C6ZZ-65023445AQ
66	Coupe/fastback, dark red	.....	C6ZZ-65023445DR
66	Coupe/fastback, light blue	.....	C6ZZ-65023445LB
66	Coupe/fastback, parchment	.....	C6ZZ-65023445PR
66	Coupe/fastback, aqua	.....	C6ZZ-76023445AQ
66	Convertible, dark red	..	C6ZZ-76023445DR
66	Convertible, light blue	C6ZZ-76023445LB	
66	Convertible, parchment	.....	C6ZZ-76023445PR
67	Coupe/fastback, dark red	.....	C7ZZ-65023445DR
67-68	Coupe/fastback, blue	C7ZZ-65023445BL	
67-68	Coupe/fastback, ivy gold	.....	C7ZZ-65023445IG
67-68	Coupe/fastback, parchment	.....	C7ZZ-65023445PR
67-68	Coupe/fastback, saddle	.....	C7ZZ-65023445SA
67-68	Coupe/fastback, turquoise	.....	C7ZZ-65023445TQ
67-68	Convertible, blue	.....	C7ZZ-76023445BL
67-68	Convertible, dark red	..	C7ZZ-76023445DR

67-68	Convertible, ivy gold	..	C7ZZ-76023445IG
67-68	Convertible, parchment	.....	C7ZZ-76023445PR
67-68	Convertible, saddle	...	C7ZZ-76023445SA
67-68	Convertible, turquoise	C7ZZ-76023445TQ	
68	Coupe/fastback, maroon	.....	C8ZZ-65023445MA
68	Coupe/fastback, nugget gold	.....	C8ZZ-65023445NG
68	Convertible, maroon	C8ZZ-76023445MR	
68	Convertible, nugget gold	.....	C8ZZ-76023445NG

### KICK PANEL SCREWS



Chrome plated broad head screws to secure plastic kick panels in position. Kit does one car.

#### Kick Panel Screws

64-68	.....	350075-SK
-------	-------	-----------

### 69-70 KICK PANELS



Exact reproduction. Injection molded black plastic. Very nice.

#### Kick Panels, 69-70

69-70	Black	.....	C9ZZ-6502344/5
-------	-------	-------	----------------

### 64-66 KICK PANELS FOR SPEAKERS



The perfect place to install a speaker without doing permanent damage. These new vacuum formed panels feature

original style grain and raised platform for speaker installation. Improve sound quality while maintaining factory appearance. Speakers not included. See audio section for kick panel with speakers. Note: Panels can be modified to fit 67-68, requires trimming on top.

#### Kick Panels For Speakers, 64-66

64-66	Coupe/fastback, black, also fits 67-68 with modifications	...	C5ZZ-65023445SP
64-66	Convertible, black, also fits 67-68 with modifications	.....	C5ZZ-76023445SP

**WE PROUDLY FEATURE AUTHENTIC MUSTANG REPRODUCTIONS FROM SCOTT DRAKE ENTERPRISES!**



## OVERHEAD COMPONENTS

### COAT HOOK

Coat Hooks are a great way to dress up your interior and install with ease.

#### Coat Hook



64-66: Chrome  
C4AZ-6229025-A



64-67: 64-66 Convertible, 67 Coupe/Fastback, Chrome  
B2A-7029025-A



68-73: Black, without base  
C8AZ-6229024-A

### COURTESY LIGHT BRACKET



Stamped metal bracket mounts under dash. Socket not included.

#### Courtesy Light Bracket

64-69 ..... COAZ-13763-A

### DOME LIGHT ASSEMBLY



We made a bright chrome base with a brighter than original bulb to really improve lighting inside the car. We include

instructions on how to easily add this dome lamp to earlier Mustangs that didn't have this feature. Our dome light assembly can even be mounted up under the back deck to make a great trunk light. Our reproduction dome lens and chrome bezel as well as the mounting hardware and electrical connectors are included to make this a quick and simple project.

#### Dome Light Assembly

65-70 ..... COAF-13A719-B

### LED DOME LIGHT ASSEMBLY



Kit comes complete with housing, hardware, and modern, smart LED module! This dome light is 5x brighter and

automatically dims after 10 minutes, and turns

off after 15 minutes. Lifetime warranty!

#### Dome Light Assembly, LED

64-70 ..... SD-DOME-LED-WH

### DOME LIGHT HOUSING

Housing is chromed plastic.

#### Dome Light Housing



67-70  
COAF-13788-A



71-73: Includes bulb  
D6UZ-13788-A

### DOME LIGHT LENS

High quality injection molded parts, exactly like the originals. Lens is milk white.

#### Dome Light Lens



67-70  
COAF-13783-C



71-73  
D1AZ-13783-B

### REAR VIEW MIRROR

Exact copies, with all the right details. Improved mirror with superior quality crimping of frame to glass.

#### Rear View Mirror



64-66: Show quality  
C5Z-17700-A



64-65: Day/Night push button  
C5Z-17700-B



65-66: Day/Night turn button  
C6Z-17700-A



67: Day/Night  
C7Z-17700-A

### Rear View Mirror



68-69: Day/Night, concours  
C7AZ-17700-G



68-70: Day/Night, aftermarket  
C8AZ-17700-A

### REAR VIEW MIRROR AND ARM KIT



Save money with this quite attractive new kit. Includes standard mirror and our pressure die cast arm.

#### Rear View Mirror and Arm Kit

64-66 ..... KIT-MIR-1

### REAR VIEW MIRROR ARM

Pressure die cast, with quality chrome.

Replaces one of the most visible interior parts.

#### Rear View Mirror Arm



64-66: Concours chrome  
C5Z-17690-D



67: Concours 2-piece design  
C7Z-17690-A



68-69: Satin  
C2SZ-17690-F

### REAR VIEW MIRROR MOUNT



Special cast-metal bracket glues to windshield. Plain finish. Exact detail.

#### Rear View Mirror Mount

68-69 ..... C8AZ-17698-A

70-79 ..... C9AZ-17698-A

### ROLL BAR



It is attractively finished in a black textured powder coated surface. Installation requires welding at floor mounts. This roll bar will fit 65-66 Fastbacks with minor modification to floor mounts. Roof

mounts. This roll bar will fit 65-66 Fastbacks with minor modification to floor mounts. Roof

mount brackets and seat belt brackets are included. Must be shipped truck freight. We can drop ship from Midwest manufacturer for East Coast customers. Similar to 67-68 Shelby.

**Roll Bar**  
65-68 Fastback ..... S7MS-RB

**CONVERTIBLE SUN VISOR**



Convertible visors are covered in the original Sierra Grain vinyl.

**Sun Visor, Convertible**

- 64-65 Medium blue ..... CSZZ-7604104-BL
- 64-65 Bright red ..... CSZZ-7604104-BR
- 64-66 Black ..... CSZZ-7604104-BK
- 64-66 Emberglo ..... CSZZ-7604104-EM
- 64-66 Ivy gold ..... CSZZ-7604104-IG
- 64-66 Palamino ..... CSZZ-7604104-PA
- 64-66 Turquoise ..... CSZZ-7604104-TQ
- 64-66 White ..... CSZZ-7604104-WT
- 65-66 Aqua ..... CSZZ-7604104-AQ
- 66 Dark red ..... CSZZ-7604104-DR
- 66 Light blue ..... CSZZ-7604104-LB
- 66 Parchment ..... CSZZ-7604104-PR
- 67-68 Aqua ..... C7ZZ-7604104-AQ
- 67-68 Black ..... C7ZZ-7604104-BK
- 67-68 Dark blue ..... C7ZZ-7604104-DB
- 67-68 Dark red ..... C7ZZ-7604104-DR
- 67-68 Ivy gold ..... C7ZZ-7604104-IG
- 67-68 Light blue ..... C7ZZ-7604104-LB
- 67-68 Parchment ..... C7ZZ-7604104-PR
- 67-68 Saddle ..... C7ZZ-7604104-SA
- 67-68 White ..... C7ZZ-7604104-WT
- 68 Maroon ..... C7ZZ-7604104-MR
- 68 Nugget gold ..... C7ZZ-7604104-NG
- 69-73 Black ..... C9ZZ-7604104-BK
- 69-73 Blue ..... C9ZZ-7604104-BL
- 69-73 Dark ivy ..... C9ZZ-7604104-DI
- 69-73 Dark red ..... C9ZZ-7604104-DR
- 69-73 Green ..... C9ZZ-7604104-GR
- 69-73 Ivy gold ..... C9ZZ-7604104-IG
- 69-73 Light blue ..... C9ZZ-7604104-LB
- 69-73 Nugget gold ..... C9ZZ-7604104-LN
- 69-73 Parchment ..... C9ZZ-7604104-PR
- 69-73 Vermillion ..... C9ZZ-7604104-VE
- 69-73 White ..... C9ZZ-7604104-WT

**COUPE AND FASTBACK SUN VISOR**



Coupe and Fastback visors are fully padded and covered with the original Moonskin Vinyl on 1964-1970 and with Tier Grain on

1971-1973.

**Sun Visor, Coupe and Fastback**

- 64-65 Medium blue ..... CSZZ-6504104-BL
- 64-65 Bright red ..... CSZZ-6504104-BR

**Sun Visor, Coupe and Fastback**

- 64-66 Black ..... CSZZ-6504104-BK
- 64-66 Ivy gold ..... CSZZ-6504104-IG
- 64-66 Light green/ivy gold ..CSZZ-6504104-LG
- 64-66 White .....CSZZ-6504104-WT
- 65-66 Parchment ..... CSZZ-6504104-PR
- 66 Aqua ..... CSZZ-6504104-AQ
- 66 Dark red ..... CSZZ-6504104-DR
- 66 Light blue .....CSZZ-6504104-LB
- 66 Turquoise .....CSZZ-6504104-TQ
- 67-68 Aqua ..... C7ZZ-6504104-AQ
- 67-68 Black ..... C7ZZ-6504104-BK
- 67-68 Dark red ..... C7ZZ-6504104-DR
- 67-68 Ivy gold ..... C7ZZ-6504104-IG
- 67-68 Light blue .....C7ZZ-6504104-LB
- 67-68 Light green/ivy gold ..C7ZZ-6504104-LG
- 67-68 Parchment ..... C7ZZ-6504104-PR
- 67-68 Saddle .....C7ZZ-6504104-SA
- 67-68 White .....C7ZZ-6504104-WT
- 69-70 Black ..... C9ZZ-6504104-BK
- 69-70 Medium blue .....C9ZZ-6504104-BL
- 69-70 Dark green .....C9ZZ-6504104-DG
- 69-70 Dark red .....C9ZZ-6504104-DR
- 69-70 Ivy gold ..... C9ZZ-6504104-IG
- 69-70 Light blue .....C9ZZ-6504104-LB
- 69-70 Parchment ..... C9ZZ-6504104-PR
- 69-70 White .....C9ZZ-6504104-WT
- 71-73 Black ..... D1ZZ-6504104-BK
- 71-73 Blue ..... D1ZZ-6504104-BL
- 71-73 Dark green .....D1ZZ-6504104-DG
- 71-73 Ginger .....D1ZZ-6504104-GI
- 71-73 Maroon ..... D1ZZ-6504104-MR
- 71-73 Red .....D1ZZ-6504104-RD
- 71-73 White ..... D1ZZ-6504104-WT

**CENTER SUN VISOR BRACKET**

Plastic molded with original looking texture.  
**Sun Visor Bracket, Center**



68-73: Black, 68 All; 69-73 Convertible  
C8ZZ-6204132-BK



68-73: 68 All; 69-73 Convertible, Neutral/Parchment  
C8ZZ-6204132-NE



69-70: Coupe/Fastback, Black  
C9AZ-6204132

**SUN VISOR BRACKET & ROD**



Set includes brackets with visor pivots and inner rods. These are perfect parts! Coupe/Fastback. For convertible sun visor

brackets & rods, see the "Convertible" category, earlier in this catalog.

- Sun Visor Bracket & Rod**  
64-66 Chrome ..... CSZZ-6504144-A  
67-70 Chrome ..... C7AZ-6204144-A

**SUN VISOR PIN AND TIP**



Gray plastic rod with rubber tip. Fits most Ford's from the 70's.

**Sun Visor Pin and Tip**

- 70-73 Pin and tip ..... D3AZ-6504114-B

**SUN VISOR TIP**



Soft rubber tips to go over the ends of the sun visor rods. Original gray color.

**Sun Visor Tip**

- 64-73 ..... D1DZ-6204115-A

**VINYL TOP**



**Vinyl Top**

- 64-70 Black ..... VT-65-BK  
64-70 White ..... VT-65-WT

**VINYL TOP MOLDING**



Pressure die cast construction and chrome plated. Coupe only.

**Vinyl Top Molding**

- 65-66 ..... CSZZ-65423A18/9  
67-68 ..... C7ZZ-65423A18/9

**WINDLACE**



Snap on vinyl windlace, available in a variety of colors. Sold by the foot. Fastbacks and coupes require 16 feet, convertibles

require 10 feet.

**Windlace**

- 64-70 Aqua ..... CSZZ-6502906-AQ
- 64-70 Black ..... CSZZ-6502906-BK
- 64-70 Medium blue .....CSZZ-6502906-BL
- 64-70 Bright red ..... CSZZ-6502906-BR
- 64-70 Dark blue ..... CSZZ-6502906-DB
- 64-70 Dark red ..... CSZZ-6502906-DR

Interior

**WE PROUDLY FEATURE AUTHENTIC MUSTANG REPRODUCTIONS FROM SCOTT DRAKE ENTERPRISES!**



**Windlace**

- 64-70 Ivy gold ..... CSZZ-6502906-IG
- 64-70 Light blue ..... CSZZ-6502906-LB
- 64-70 Parchment ..... CSZZ-6502906-PA
- 64-70 Saddle ..... CSZZ-6502906-SA
- 64-70 White ..... CSZZ-6502906-WT

**PEDALS, PADS AND TRIM**

**ACCELERATOR PEDAL**

These steel reinforced parts are molded from high quality rubber for a long life and great appearance.

**Accelerator Pedal**



64-68: With stainless trim  
CSZZ-9735-D



69-70: Without trim  
C9Z-9735-D



71-73 Acc pedal w/o trim  
D1ZZ-9735

**ACCELERATOR PEDAL MOUNTING SCREW**

A precision machined screw with exact detail. Painted black.



**Accelerator Pedal Mounting Screw**

- 64-68 ..... 380503-S101

**ACCELERATOR PEDAL SPRING**

Made of strong spring steel for a long life.



**Accelerator Pedal Spring**

- 64-68 ..... CSZZ-9760-B
- 69-70 ..... C9OZ-9760

**BRAKE AND CLUTCH PEDAL PAD**

Sold as a matching set for the clutch and brake pedals for manual transmission cars. High quality EPDM rubber will look



great for years.

**Brake and Clutch Pedal Pad**

- 65-68 5 ..... CSZZ-2457624-50

**BRAKE PEDAL PAD**

Made by Scott Drake with exact detail of the original. Compression molded rubber. Disc brake versions include stainless steel center trim.

**Brake Pedal Pad**



64-67: With power drum brakes  
CSZZ-2457-E



64-67: Drum brakes, automatic transmission  
CSZZ-2457-F



65-73: Drum brakes, manual transmission  
CSZZ-2457-G



68-73: Drum brakes, automatic  
C6OZ-2457-A

**DISC BRAKE PEDAL PAD**

These reproduction pads are high quality replacements for worn or missing original pads.

**Brake Pedal Pad, Disc**



65-67: Disc brakes, automatic transmission  
CSZZ-2454-C



65-73: Disc brakes, manual transmission  
CSZZ-2454-D



68-73: Disc brakes, automatic transmission  
D3ZZ-2454-A

**BRAKE PEDAL PAD TRIM**

Replacement brake pedal pad trim. Stainless steel construction.



**Brake Pedal Pad Trim**

- 65-67 Automatic transmission .. CSZZ-2A487-B
- 65-73 Manual transmission ..... D1ZZ-2A487-B
- 68-73 Automatic transmission .. C6OZ-2A487-A

**CLUTCH PEDAL PAD**

These reproduction pads are high quality replacements for worn or missing original pads.

**Clutch Pedal Pad**



65-68  
CSZZ-7A624-B



69-73  
C9ZZ-7A624-A

**CLUTCH PEDAL PAD TRIM**

Replacement clutch pedal pad trim. Stainless steel construction.



**Clutch Pedal Pad Trim**

- 65-68 ..... CSZZ-7B544-A
- 69-73 ..... C9ZZ-7B544-A

**PARKING BRAKE PEDAL PAD**

This Parking Brake Pad is an exact copy of the original. Molded from wear resistant rubber for years of use.

**Parking Brake Pedal Pad**



69-73: Note: Will not fit 1970 Mustang or Cougar  
C9ZZ-2454-A

**PARKING BRAKE PEDAL PAD TRIM**

Made from stainless steel, just like the originals.



**Parking Brake Pedal Pad Trim**

- 69-73 Note: Will not fit 1970 Mustang or Cougar  
C9ZZ-2A487-C

**BILLET PEDAL COVERS**

Machined from solid 6061-T6 billet aluminum with a clear anodized finish, these pedal covers are a great addition to any vehicle. Includes stainless steel mounting hardware.

**Pedal Covers, Billet**



64-67: Brake pedal, automatic  
CSZZ-2457-FBL

**Pedal Covers, Billet**

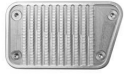

64-68: Brake pedal, manual  
CSZ-2457-GBL



64-68: Clutch pedal  
CSZ-7A624-BBL



64-68: Accelerator pedal  
CSZ-9732-DBL



65-73: 1965-73 Mustang Dimmer  
Switch Cover  
CSZ-13533-BL



68-73: Brake pedal, automatic  
C60Z-2457-ABL

**WASHER PUMP PEDAL PAD**



Great reproduction of the original, with crisp detailing in the rubber.

Washer Pump Pedal Pad  
67-68 .....C7Z-17664-P

**QUARTER PANELS**

**QUARTER PANEL ASH TRAY COVER**



Exact reproduction of the original ash trays for the convertible. Stainless cover with plastic handle, and exact reproduction

formed ashtray. Tray is zinc plated stamped steel.

Ash Tray Cover, Quarter Panel  
64-70 ..... C1AB-7630714-A

**QUARTER PANEL ASH TRAY RECEPTACLE**



Exact reproduction of the original ash trays for the convertible. Stainless cover with plastic handle, and exact reproduction

formed ashtray. Tray is zinc plated stamped

steel.  
Ash Tray Recepticle, Quarter Panel  
65-68 .....CSAZ-7630702-A

**INTERIOR QUARTER PANEL**

**Interior Quarter Panel**



64-66: Steel with embossed grain,  
Right hand  
CSZ-7631004-R



64-66: Steel with embossed grain,  
Left hand  
CSZ-7631005-L



64-68: Convertible  
CSZ-7631486/7A



65-66: Fastback, Fiberglass  
CSZ-6331486/7A



65-66: Fastback, ABS includes steel reinforcement and courtesy lights  
CSZ-63314867-K



67-68: Fastback, ABS includes steel reinforcement and courtesy lights  
C7Z-63314867-K



69-70: ABS plastic  
C9Z-6331486/7P

**QUARTER GLASS PIVOT ROD COVER**



A nice reproduction of the rubber cover for the quarter glass pivot.

Quarter Glass Pivot Rod Cover  
69-70 ..... C9Z-6330246

**QUARTER PANEL TRIM**



Die cut and carefully sewn to assure you of a proper fit. Made from the original type upholstery material. Original equipment on all convertibles and coupes with deluxe

interior.  
**Quarter Panel Trim, Convertible**

- 64-65 Medium blue ..... C6Z-74407423BL
- 64-65 White ..... C6Z-76607623WT
- 64-68 Black ..... CSZ-76607623BK
- 65 Bright red ..... CSZ-76607623BR
- 65-66 Palomino ..... CSZ-76607623PA
- 65-68 Aqua ..... C6Z-76607623AQ
- 65-68 Light blue ..... C6Z-76607623LB
- 65-68 Ivy gold ..... C7Z-76607623IG
- 66 Emberglow ..... C6Z-76607623EM
- 66 Parchment ..... C6Z-76607623PR
- 66-67 Dark red ..... C6Z-76607623DR
- 67-68 Light parchment ..... C7Z-76607623LP
- 67-68 Saddle ..... C7Z-76607623SA
- 68 Maroon ..... C8Z-76607623MR
- 68 Nugget gold ..... C8Z-76607623NG
- 69-70 Black ..... C9Z-76607623BK
- 69-70 Light blue ..... C9Z-76607623BL
- 69-70 Ivy gold ..... C9Z-76607623IG
- 69-70 Medium blue ..... C9Z-76607623MB
- 69-70 White ..... C9Z-76607623WT

**COUPE QUARTER PANEL TRIM**

**Quarter Panel Trim, Coupe**

- 64-65 Medium blue ..... C6Z-65607623BL
- 64-68 Black ..... CSZ-65607623BK
- 65 Bright red ..... CSZ-65607623BR
- 65-68 Light blue ..... CSZ-65607623LB
- 65-68 Palomino ..... CSZ-65607623PA
- 65-68 Aqua ..... C6Z-65607623AQ
- 65-68 Emberglow ..... C6Z-65607623EM
- 65-68 Turquoise ..... C6Z-65607623TQ
- 65-68 White ..... C6Z-65607623WT
- 65-68 Ivy gold ..... C7Z-65607623IG
- 66 Dark red ..... C6Z-65607623DR
- 66-68 Parchment ..... C6Z-65607623PR
- 67 Saddle ..... C7Z-65607623SA
- 67-68 Parchment ..... C7Z-65607623LP
- 68 Maroon ..... C8Z-65607623MR
- 68 Nugget gold ..... C8Z-65607623NG

**QUARTER PANEL TRIM CAP**

These are excellent reproductions. Sold in pairs only. 65-66 version is made from polished stainless. 69-70 version is black plastic with correct texture.

**Quarter Panel Trim Cap**



65-66: Coupe, Pony interior  
CSZ-6531490/1



69-70: Fastback  
C9Z-6331490/1A

Interior

**WE PROUDLY FEATURE AUTHENTIC MUSTANG REPRODUCTIONS FROM SCOTT DRAKE ENTERPRISES!**



**135**



**CONVERTIBLE QUARTER PANEL TRIM PAD KIT**



**Quarter Panel Trim Pad Kit, Convertible**  
64-68 .....CSZZ-76314867PK

**QUARTER PANEL WINDLACE**

These are the upholstery strips that finish off the inside quarter panel.



**Quarter Panel Windlace**

- 69 Dark Red .....C9ZZ-6531290-DR
- 69 Ivy Gold .....C9ZZ-6531290-IG
- 69 Light Blue .....C9ZZ-6531290-LB
- 69 Nugget Gold .....C9ZZ-6531290-NG
- 69-70 Black .....C9ZZ-6531290-BK
- 69-70 White .....C9ZZ-6531290-WT
- 70 Ginger .....D0ZZ-6531290-GI
- 70 Ivy green .....D0ZZ-6531290-IG
- 70 Medium blue .....D0ZZ-6531290-MB
- 71-73 Black .....D1ZZ-6531290-BK
- 71-73 Blue .....D1ZZ-6531290-BL
- 71-73 Ginger .....D1ZZ-6531290-GI
- 71-73 Green .....D1ZZ-6531290-GR
- 71-73 Vermillion .....D1ZZ-6531290-VE
- 71-73 White .....D1ZZ-6531290-WT

**QUARTER PANEL WINDOW HANDLE**



A nice reproduction. Die cast construction with good chrome plating. Hardware included.

**Quarter Panel Window Handle**

- 69-70 Fastback .....C9ZZ-6330204/52

**RALLY PACS & GAUGE POD ASSEMBLIES**

**POLISHED ALUMINUM BULLET**



Another creative custom accent by Scott Drake. We have precision machined our aluminum bullets and finished them

off with a beautiful polish. These look great on the face of the Tri-bar head lamps or as replacement center ornaments on a 1966 Rally Pac. Limitless possibilities for all other cars as well. Use silicone adhesive to secure.

**Bullet, Polished Aluminum**

- 64-73 .....ACC-BULLITTS

**1967 UNDER DASH GAUGE POD ASSEMBLY**



We are proud to have the Scott Drake name on this Gauge Pod Assembly, an authentic reproduction of the original 1967 Shelby

under dash gauge pod! Features Stewart Warner green line gauges and a tough, crinkle coated housing. Includes oil pressure & Amp gauges, mounting bracket, face plate, and all hardware and connectors needed for proper installation. Fits 1967 Shelby and 1967-68 Mustangs without center console. Universal fit for other under dash applications may also be possible.

**Gauge Pod Assembly, 1967 Under Dash**

- 67-68 Black .....S7MS-10B969-A

**1967 UNDER DASH GAUGE POD BRACKET**



Never before available. We have reproduced the hanging bracket for the under dash gauge pod originally found in the 1967

Shelby. Made of heavy duty steel with exact detail and painted flat black.

**Gauge Pod Bracket, 1967 Under Dash**

- 67 .....S7MS-3676-A

**1967 UNDER DASH GAUGE POD FACE PLATE**



We have reproduced the original face plate for the 1967 Shelby underdash gauge pod. Features black wrinkle finish just like the

original.

**Gauge Pod Face Plate, 1967 Under Dash**

- 67 .....S7MS-17187-A

**RALLY PAC**

This is the Ultimate accessory for your 65-66 Mustang. Our Rally Pac features a modern air-core movement tachometer and a quartz movement clock. Both the clock and tachometer faces feature the original style fonts and are back lit for improved visibility at night. The housing and bezels are pressure zinc die-cast from our own tooling and coated with a tough Du Pont crinkle texture. Our Rally Pac's include all of the brackets, color coded wire harnesses and easy to follow installation instructions. Available in the 6 most popular 1966 Mustang interior colors, new Satin chrome, or any original interior

color by special order. Available for 6 or 8 cylinder engine applications.



- 64-65 6000 Rpm black .....CSZZ-10B960CBK
- 64-65 6000 RPM Chrome ...CSZZ-10B960CBKC
- 64-65 8000 RPM black .....CSZZ-10B960KBK
- 64-65 8000 RPM black/chrome .....CSZZ-10B960KBKC



- 65-66 V8, 6000 RPM, black ...C6ZZ-10B960CBK
- 65-66 V8, 6000 RPM, satin ....C6ZZ-10B960CSN
- 65-66 V8, 6000 RPM, white .C6ZZ-10B960CWT
- 65-66 V8, 8000 RPM, black ..C6ZZ-10B960KBK
- 65-66 V8, 8000 RPM, satin ...C6ZZ-10B960KSN
- 65-66 V8, 8000 RPM, white C6ZZ-10B960KWT
- 65-66 6 cylinder, 6000 RPM, black .....C6ZZ-10B960TBK

- 65-66 6 cylinder, 6000 RPM, satin .....C6ZZ-10B960TSN
- 65-66 6 cylinder, 6000 RPM, white .....C6ZZ-10B960TWT

- 66 V8, 6000 RPM, aqua ..C6ZZ-10B960CAQ
- 66 V8, 6000 RPM, dark red .....C6ZZ-10B960CDR
- 66 V8, 6000 RPM, ivy gold C6ZZ-10B960CIG
- 66 V8, 6000 RPM, light blue .....C6ZZ-10B960CLB
- 66 V8, 6000 RPM, parchment .....C6ZZ-10B960CPA

- 66 V8, 8000 RPM, aqua ..C6ZZ-10B960KAQ
- 66 V8, 8000 RPM, dark red .....C6ZZ-10B960KDR
- 66 V8, 8000 RPM, ivy gold C6ZZ-10B960KIG
- 66 V8, 8000 RPM, light blue .....C6ZZ-10B960KLB
- 66 V8, 8000 RPM, parchment .....C6ZZ-10B960KPA

- 66 6 cylinder, 6000 RPM, aqua .....C6ZZ-10B960TAQ
- 66 6 cylinder, 6000 RPM, dark red .....C6ZZ-10B960TDR
- 66 6 cyl., 6000 RPM, ivy gold .....C6ZZ-10B960TIG
- 66 6 cylinder, 6000 RPM, light blue .....C6ZZ-10B960TLB

66 6 cylinder, 6000 RPM, parchment .....  
C6ZZ-10B960TPA

**ELECTRO LUMINESCENT RALLY PAC**



Due to the popularity of our Electro Luminescent instrument panels, we have incorporated this technology into our

Rally Pacs. These are the same high quality gauges as the regular Rally Pac. Note: You must use the EL instrument cluster in order to power the Rally Pacs EL faces, cannot be used seperately.

- Rally Pac, Electro Luminescent**
- 66 V8, 6000 RPM, aqua .C6ZZ-10B960CAQE
  - 66 V8, 6000 RPM, black .C6ZZ-10B960CBKE
  - 66 V8, 6000 RPM, dark red .....  
C6ZZ-10B960CDRE
  - 66 V8, 6000 RPM, light blue .....  
C6ZZ-10B960CLBE
  - 66 V8, 6000 RPM, parchment .....  
C6ZZ-10B960CPAE
  - 66 V8, 6000 RPM, satin ..C6ZZ-10B960CSNE
  - 66 V8, 6000 RPM, white C6ZZ-10B960CWTE
  - 66 V8, 8000 RPM, aqua .C6ZZ-10B960KAQE
  - 66 V8, 8000 RPM, black .C6ZZ-10B960KBKE
  - 66 V8, 8000 RPM, dark red .....  
C6ZZ-10B960KDRE
  - 66 V8, 8000 RPM, light blue .....  
C6ZZ-10B960KLBE
  - 66 V8, 8000 RPM, parchment .....  
C6ZZ-10B960KPAE
  - 66 V8, 8000 RPM, satin ..C6ZZ-10B960KSNE
  - 66 V8, 8000 RPM, white C6ZZ-10B960KWTE

**RALLY PAC CENTER DIAL**

Chrome plated dial ornament.



**Rally Pac Center Dial**  
66 .....C6ZZ-10C858-D

**RALLY PAC CLOCK BULB**



Replacement bulbs from O.E.M. suppliers to the auto industry. Excellent quality bulbs. Fits original Rally Pacs only.

**Rally Pac Clock Bulb**  
65-66 ..... 1816

**RALLY PAC DUAL GAUGE HOUSING**



Rally Pac housing and bezels are now available without gauges so that you may add your favorite gauges for a custom

project. Our housing can be mounted on the steering column or under the dash with the use of various brackets, available separately. Modifications are required to make aftermarket 2 5/16 inch gauges fit our housing and bezels. Included in this package are 2 chrome inner bezel rings and 2 gauge mounting compression rings.

- Rally Pac Dual Gauge Housing**
- 65-68 Black .....S7MS-10B960-BK
  - 65-68 Satin .....S7MS-10B960-S
  - 65-68 White .....S7MS-10B960-WT

**RALLY PAC LENSES**

Fabricated plastic construction.



- Rally Pac Lenses**
- 65 Clock .....C5ZZ-15000-L
  - 65 Tach .....C5ZZ-17360-L
  - 66 Clock .....C6ZZ-15000-L
  - 66 Tach .....C6ZZ-17306-L

**RALLY PAC MOUNTING CLAMP**



Holds rally pack to steering column. Stamped steel and painted black. Includes rubber pad and mounting screws.

**Rally Pac Mounting Clamp**  
65 .....C5ZZ-3676-A

**RALLY PAC MOUNTING KIT**



Includes mounting clamp, wire channel cover, rubber pad and mounting hardware. This kit is included when purchasing our

- new RallyPac.  
**Rally Pac Mounting Kit**
- 66 Black .....C6ZZ-3678-AK
  - 66 White .....C6ZZ-3678-WK

**RALLY PAC REPAIR PIGTAIL KIT**



This repair harness is used to replace Rally-Pacs with damaged leads. Kit includes clock and tach harness plus four crimp on

- connectors.  
**Rally Pac Repair Pigtail Kit**
- 64-65 .....C5ZZ-15A006-FX
  - 65-66 .....C6ZZ-15A006-FX

**RALLY PAC THEFT PROTECTION**

**SCREW**



Design especially for rally-pac mounting. These specialty screws will slow down any thief. Kit includes two black button-head

socket screws, lock washers and special tool to install and remove.  
**Rally Pac Theft Protection Screw**

- 64-66 .....379773-S

**RALLY PAC TRIM RING**

Chrome plated plastic trim ring. Sold individually.



**Rally Pac Trim Ring**  
66 .....C6ZZ-10C858-A

**RALLY PAC UNDER DASH HARNESS**



Harness that plugs into main under dash harness. This harness must be used when installing a Rally Pac in a car that did not

originally come with one.  
**Rally Pac Under Dash Harness**

- 64-66 .....C5ZZ-15A006-UD

**SHELBY TACH DASH BRACKET**



Concours correct reproduction with wrinkle finish. Stamped steel.

**Tach Dash Bracket, Shelby**  
66 .....S2MS-17360-B

**REAR DECK**

**COUPE VINYL PACKAGE TRAY**



Designed to match your interior for a clean, finished look. Made of tough masonite and vinyl. Easy to install. Also

available with speaker holes.  
**Package Tray, Coupe Vinyl**

- 64-65 Dark blue .....C5ZZ-6546656-BL

Interior

**WE PROUDLY FEATURE AUTHENTIC MUSTANG REPRODUCTIONS FROM SCOTT DRAKE ENTERPRISES!**



**Package Tray, Coupe Vinyl**

64-68	Black	.....	C5ZZ-6546656-BK
65	Palomino	.....	C5ZZ-6546656-PA
65	Bright red	.....	C5ZZ-6546656-RD
65-66	Emberglow	.....	C5ZZ-6546656-EM
65-66	White	.....	C5ZZ-6546656-WT
65-68	Aqua	.....	C5ZZ-6546656-AQ
65-68	Ivy gold	.....	C5ZZ-6546656-IG
65-68	Light blue	.....	C5ZZ-6546656-LB
66	Parchment	.....	C5ZZ-6546656-PR
66-67	Dark red	.....	C5ZZ-6546656-DR
67-68	Parchment	.....	C7ZZ-6546656-PR
67-68	Saddle	.....	C7ZZ-6546656-SA
68	Dark red	.....	C8ZZ-6546656-DR
68	Nugget gold	.....	C8ZZ-6546656-NG

**FIBERGLASS AND FIBERBOARD PACKAGE TRAY**



**Package Tray, Fiberglass and Fiberboard**

64-68	Coupe, fiberboard	.....	C5ZZ-6546656
67-68	Fastback, fiberboard, no fold down seat	.....	C7ZZ-6346656
69-70	Fastback, fiberglass	.....	C9ZZ-6346656
69-70	Coupe, fiberglass	.....	C9ZZ-6546656
69-70	Fastback, fiberboard	...	C9ZZ-6546656-C

**COUPE VINYL PACKAGE TRAY WITH HOLES**



Designed to match your interior for a clean, finished look. Made of tough masonite and vinyl. Easy to install. These

come with precut speaker holes.

**Package Tray With Holes, Coupe Vinyl**

64-67	Aqua	.....	C5ZZ-6546656-AQH
64-67	Black	.....	C5ZZ-6546656-BKH
65	Dark blue	.....	C5ZZ-6546656-BLH
65	Palomino	.....	C5ZZ-6546656-PAH
65	Red	.....	C5ZZ-6546656-RDH
65-66	White	.....	C5ZZ-6546656-WTH
65-67	Ivy gold	.....	C5ZZ-6546656-IGH
65-67	Light blue	.....	C5ZZ-6546656-LBH
66	Emberglow	.....	C5ZZ-6546656-EMH
66	Parchment	.....	C5ZZ-6546656-PRH
66-67	Dark red	.....	C5ZZ-6546656-DRH

**Package Tray With Holes, Coupe Vinyl**

68	Aqua	.....	C7ZZ-6546656-AQH
68	Black	.....	C7ZZ-6546656-BKH
68	Dark red	.....	C7ZZ-6546656-DRH
68	Ivy gold	.....	C7ZZ-6546656-IGH
68	Light blue	.....	C7ZZ-6546656-LBH
68	Parchment	.....	C7ZZ-6546656-PRH
68	Saddle	.....	C7ZZ-6546656-SAH
68	Dark red	.....	C8ZZ-6546656-DRH
68	Nugget gold	.....	C8ZZ-6546656-NGH

**SEAT BELTS**

**3 INCH RACE STYLE LAP BELT**



Get that Cool Vintage Race Car look that was used in many competition cars during the 1960's including 1965-66

Shelby's. Extra wide 3" belt with quick release latch and a genuine Leather Protective Pad adds some extra safety over stock lap belts. Mounting Hardware included.

**3 inch Race Style Lap Belt**

64-73	Black	.....	SB-RACE
-------	-------	-------	---------

**RETRACTABLE 3 POINT SEAT BELT**



This product allows you to convert your 1964-67 Mustang Coupe, Fastback or Convertible's seat belts to a safer, modern

3-Point design. This is today's technology for yesterday's classic car. This Seat Belt Kit comes complete with all the hardware needed along with instructions to guide you through the installation. Available in a variety of colors. This Kit will also work on 68-73 Mustangs, but if you use existing roof mounting point, the webbing may be too short for some Drivers. For 1968-73 customers looking for a more original appearance and wishing to use their factory Roof mounting point we offer SB-3P-BK-PBSB in Black only. All of the Seat Belts are made in the U.S.A. and are built under the current Governments safety guidelines.

**3 Point Seat Belt, Retractable**

64-73	Black	.....	SB-3P-BK
64-73	Blue	.....	SB-3P-BL
64-73	Bright Red	.....	SB-3P-BR
64-73	Green	.....	SB-3P-GN
64-73	Light Blue	.....	SB-3P-LB
64-73	Parchment	.....	SB-3P-PR
64-73	White	.....	SB-3P-WT



Are you looking to replace or upgrade your complicated 1968-73 3 Point Seat Belts with a modern easy to use factory

looking Belt? Scott Drake now has a great option. These 3 Point Seat Belts will bolt onto any 1968-73 Coupe or Fastback using your existing mounting hardware. For all customers with 1964-67 Coupes or 1968-73 Convertibles wishing to add 3 point Seat Belts to your car you will need to buy two Hardware Mounting Kits, part # SB-3P-HK. The belt buckles are very similar to the original buckles Ford used in the Late 1960's and early 1970's and even feature an exact copy of the Starburst emblem.

**Seat Belt, Black Wrinkle**

64-73	3 Pt Seat Belts with Vintage Push Button	.....	SB-3P-BK-PBSB
-------	--	-------	---------------

**3 POINT SEAT BELT HARDWARE**



Mounting hardware is Grade 5 hardness to ensure maximum safety. This mounting kit is specifically designed for

Mustangs. Not a universal kit. Includes instructions. 2 required per car. This is included in our Retractable 3-Point Seat Belt kits except SB-3P-BK-PBSB.

**3 Point Seat Belt Hardware**

64-73	3 Point	.....	SB-3P-HK
-------	---------	-------	----------

**AFTERMARKET SEAT BELT**



Great looking replacement style seat belts. All feature a mid sixties period look which includes a chrome buckle.

Available in a variety of colors.

**Seat Belt, Aftermarket**

60-73	Aqua	.....	SB-AQ
60-73	Black	.....	SB-BK
60-73	Light blue	.....	SB-LB
64-73	Medium blue	.....	SB-BL
64-73	Bright red	.....	SB-BR
64-73	Dark blue	.....	SB-DB
64-73	Dark red	.....	SB-DR
64-73	Light green	.....	SB-GN
64-73	Maroon	.....	SB-MR
64-73	Parchment/palomino	.....	SB-PR
64-73	Saddle	.....	SB-SA
64-73	White	.....	SB-WT

### BLACK WRINKLE SEAT BELT



Exclusively from Scott Drake. We had these seat belts powder coated black with a textured finish to more closely resemble

original style seat belts. Includes mounting hardware.

#### Seat Belt, Black Wrinkle

64-73 Black wrinkle ..... SB-BK-DLX

### MUSTANG EMBLEM SEAT BELT



These aftermarket seat belts are sure to turn heads. Replace your old belts

with these new ones that feature a pair of brilliantly painted Tri-bar pony emblems. Available in all popular colors. Sold in matching pairs with all hardware included for easy installation.

#### Seat Belt, Mustang Emblem

64-73 Aqua\* ..... SB-AQ-H

64-73 Black\* ..... SB-BK-H

64-73 Medium Blue\* ..... SB-BL-H

64-73 Bright red\* ..... SB-BR-H

64-73 Dark blue\* ..... SB-DB-H

64-73 Dark red\* ..... SB-DR-H

64-73 Green\* ..... SB-GN-H

64-73 Light Blue ..... SB-LB-H

64-73 Maroon\* ..... SB-MR-H

64-73 Parchment\* ..... SB-PR-H

64-73 Saddle\* ..... SB-SA-H

64-73 White\* ..... SB-WT-H

### PUSH BUTTON SEAT BELT



From Scott Drake, these are original looking seat belts at affordable prices. These are not

Concours reproductions, but have the correct vintage look used by Ford on several cars in the Mid to Late 1960's. Starburst Medallion used on the buckle is an exact copy of originals. Hardware included!

#### Seat Belt, Push Button

64-73 Black ..... SB-BK-PBSB

64-73 Aqua ..... SB-AQ-PBSB

64-73 Medium Blue ..... SB-BL-PBSB

64-73 Bright Red ..... SB-BR-PBSB

64-73 Dark Blue ..... SB-DB-PBSB

64-73 Dark Red ..... SB-DR-PBSB

64-73 Green ..... SB-GN-PBSB

64-73 Maroon ..... SB-MR-PBSB

64-73 Parchment ..... SB-PR-PBSB

64-73 Saddle ..... SB-SA-PBSB

64-73 White ..... SB-WT-PBSB

#### Seat Belt, Push Button

64-73 Light Blue ..... SB-LB-PBSB

### RETRACTABLE SEAT BELT

Great looking replacement style seat belts. All feature a mid sixties period look which includes a chrome buckle.

#### Seat Belt, Retractable



64-73: Black, low profile retractor, (Will not fit 64-67 convertibles) SB-BK-65



68-73: Black, fits Coupe/Fastback, \*will fit 64-67 but not recommended for taller drivers SB-BK-68

### CHROME SEAT BELT BOLT SET

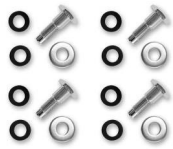

Concours correct for 65-67, but a nice dress-up item for 68-73. This bolt set would compliment any of our seat belts for a more

original appearance.

#### Seat Belt Bolt Set, Chrome

64-73 Chrome ..... 382627-K

### SEAT BELT BUCKLE BEZEL



Replace those worn buckle bezels with our new chromed bezels. They just snap on. Brings life back to those old seat belts.

#### Seat Belt Buckle Bezel

68-70 ..... C8AZ-65611A72-A

### SEAT BELT BUCKLE BUTTON COVER



Exact detail of the seat belt buckle release button.

#### Seat Belt Buckle Button Cover

68-70 ..... C8AZ-65611C02-A

### SEAT BELT BUCKLE RESTORATION KIT



#### KIT

Perfect reproductions of commonly worn parts. Now bring those old seat belt buckles back with our chrome bezels & highly

detailed release button covers. One kit does a pair of belts.

#### Seat Belt Buckle Restoration Kit

68-70 ..... C8AZ-65611A72-K

### SEAT BELT HOLDER



Holds seat belt in place when belts are not in use. Mounts to roof.

#### Seat Belt Holder

71-73 ..... D1ZZ-6561280

### SEAT BELT RETRACTOR



A great way to "tidy up" your interior as well as make your seat belts easier to use. Just pre-wind these retractors and insert the belt

into the notches, let go and the belt will roll up and stay in easy reach. Exact copy of Ford accessory.

#### Seat Belt Retractor

64-67 U.S.A., concours ..... C4AZ-65611A06

64-67 Imported, reproduction ..... C4AZ-65611A06-R

## SEAT COMPONENTS

### COMPLETE SEAT FRAME



#### Complete Seat Frame

65-67 Right Hand ..... CSZZ-6563102-S

65-67 Left Hand ..... CSZZ-6563103-S

### SEAT BOTTOM FRAME



The bottom frame and spring assembly for the bucket seat.

#### Seat Bottom Frame

64-67 Right hand ..... CSZZ-6563100-A

64-67 Left hand ..... CSZZ-6563101-A

### FRONT SEAT HINGE SHAFT

#### RETAINER CLIP SET



Special clip used to secure front seat back to seat bottom. Two required per seat.

#### Front Seat Hinge Shaft Retainer Clip Set

64-70 Set of 4 ..... 352358-SK

Interior

**WE PROUDLY FEATURE AUTHENTIC MUSTANG REPRODUCTIONS FROM SCOTT DRAKE ENTERPRISES!**



139

## FRONT SEAT WASHER



Install on seat hinge shaft between the seat and hinge to prevent hinge from wearing through upholstery.

**Front Seat Washer**  
65-73 Set of 4 .....373249-S

## HEAD REST



These headrest makes retrofitting original Mustang seat to head rest types possible. Kit includes color keyed head rest, mounting

brackets, hardware and instructions.

### Head Rest

64-67 Standard Seats, dark black	HR-BK
64-67 Standard, dark blue	HR-BL
64-67 Standard, bright red	HR-BR
64-67 Standard, dark red	HR-DR
64-67 Standard, ivy gold	HR-IG
64-67 Standard, light blue	HR-LB
64-67 Standard, palomino	HR-PA
64-67 Standard, parchment	HR-PR
64-67 Standard, saddle	HR-SA
64-67 Standard, white	HR-WT
65-67 Standard, aqua	HR-AQ
65-67 Sport seat, aqua	SS-HR-AQ
65-67 Sport seat, black	SS-HR-BK
65-67 Sport seat, light blue	SS-HR-BL
65-67 Sport seat, bright red	SS-HR-BR
65-67 Sport seat, dark red	SS-HR-DR
65-67 Sport seat, ivy gold	SS-HR-IG
65-67 Sport seat, palomino	SS-HR-PA
65-67 Sport seat, parchment	SS-HR-PR
65-67 Sport seat, white	SS-HR-WT

## HOG RING KIT



Our hog ring installation kits each feature pliers and 150 hog rings included (enough for 1 set). Economy pictured.

### Hog Ring Kit

64-73 Economy, simple pliers	PLIERSET-E
64-73 Medium, upgrade cast pliers	PLIERSET-M
64-73 Pro, spring-loaded pliers	PLIERSET-P

## SEAT ADJUSTER KNOB



Knob to adjust forward and back motion of seat slider.

**Seat Adjuster Knob**  
65-72 .....CSAZ-6261753-BA

## Seat Adjuster Knob

71 .....D1FZ-6262622B/C

## SEAT BACK ADJUSTING KIT



Includes pair of chrome screw adjusters, nuts and washers, heavy duty plastic rest plates and attaching screws.

### Seat Back Adjusting Kit

64-67 .....C1DZ-6461643

## SEAT BACKBOARD



Features correct grain and embossed stitching. Paint to match. Fits standard and deluxe seats.

### Seat Backboard

69-70 Black, ABS plastic .....C9ZZ-6560762

## SEAT BUTTON

Die cast like the originals. For deluxe interiors. New lower prices!

### Seat Button



67: Deluxe, button only (4 required per car)  
C7ZB-6564824-B



67: Deluxe, includes back plate (4 required per car)  
C7ZB-6564824-K



68: Deluxe, button only (8 required per car)  
C8ZB-6564824-A



68: Deluxe, includes back plate (8 required per car)  
C8ZB-6564824-K

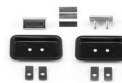

69-70: Deluxe, teak and walnut (69 cars require 4 pairs, 70 cars require 5 pairs)  
C9ZZ-6564824-W



71-73: Grande seat buttons  
D1ZB-6564824-Kse  
71-73: Mach seat buttons  
D1ZZ-6564824-K

## SEAT HINGE COVER

These hinge covers are exact copies of the originals. Exterior molded plastic.

### Seat Hinge Cover



64-67: Black  
CSZZ-6561692/3B



64-67: Neutral  
CSZZ-6561692/3N



68-70: Black  
C8AZ-6561692/5B



68-70: Neutral  
C8AZ-6561692/5N



71-73: Black  
D1ZZ-6561692/3

## SEAT HINGE REPAIR BRACKET



A very common breaking point can now be easily repaired.

### Seat Hinge Repair Bracket

68-70 Inner, left hand .....D7ZZ-69618C46-A

## SEAT LATCH HANDLE AND BEZEL SET

Exact detail and beautiful chrome. These handles & bezels are commonly pitted, broken or missing. Our 6 piece kit does both front seats.

### Seat Latch Handle and Bezel Set



68-69  
C8AZ6262622/72A



70  
C9AZ-626262272A

### ALUMINUM SEAT SIDE MOLDING



Stamped aluminum as originals, clear anodized plated.

#### Seat Side Molding, Aluminum

- 64-66 Right hand ..... CSZZ-6561616-AR
- 64-66 Left hand ..... CSZZ-6561617-AR
- 67 Right Hand ..... C7ZZ-6561616-AR
- 67 Left Hand ..... C7ZZ-6561617-AR

### FIBERGLASS SEAT SIDE MOLDING



Nice quality fiber glass reproductions to replace commonly broken moldings. No hardware or brackets included. Paint to

match.

#### Seat Side Molding, Fiberglass

- 67 Pair ..... C7ZZ-6567186/7

### SEAT SIDE MOLDING MOUNT KIT



This kit contains all the original style parts to mount the seat side molding. Does one seat.

#### Seat Side Molding Mount Kit

- 65-66 6 pieces ..... CSZZ-65616167MK
- 67 6 pieces ..... C7ZZ-65616167MK

### SEAT STOP BUMPER KIT



These seat bumpers install between the seat cushion and seat back. Fits many other Ford/Mercury seats.

#### Seat Stop Bumper Kit

- 68-73 ..... C8ZZ-6560310/1

### SEAT TRACK ASSEMBLY



These replacement seat track assemblies come with everything necessary to replace those hard to move or broken originals. Each

set does one seat. **Seat Track Adjuster will be available separately Late Spring 2012 under part number: C5ZZ-6561726-A.**

#### Seat Track Assembly

- 64-68 ..... CSZZ-6561704/5
- 69-70 ..... C9ZZ-6561704/5

### SEAT TRACK PLATE



Heavy steel plates, stamped in the original gauge steel. Painted black, sold individually or in sets of eight.

#### Seat Track Plate

- 64-67 Bulk ..... CSZZ-13190-A
- 64-67 Set of 8 ..... CSZZ-13190-K

### SEAT TRACK SPRING SET



Includes all the springs necessary to rebuild one seat. Black phosphorous plated.

#### Seat Track Spring Set

- 64-70 ..... CSZZ-6561828/83

## SEATS & UPHOLSTERY

### BENCH FRONT SEAT ONLY UPHOLSTERY



These are front only seat upholstery sets for Mustangs with a front bench seat. Our upholstery sets are the best on the market,

precision made from the same heavy duty vinyl and attention to detail originally used by Ford. Our custom colors are an exact match. Heavy 32 ounce vinyl and solid welt cord. Patterns are die cut for precision. Kits do not include hog rings for installation.

#### Front Seat Only Upholstery, Bench

- 65 Bench, black, front only 65-B-BENCH-BK
- 65 Bench, blue, front only . 65-B-BENCH-BL
- 65 Bench, bright red, front only ..... 65-B-BENCH-BR

- 65 Bench, ivy gold, front only ..... 65-B-BENCH-IG

- 65 Bench, palomino, front only ..... 65-B-BENCH-PA

- 65 Bench, white, front only ..... 65-B-BENCH-WT

- 66 Bench, aqua, front only 66-B-BENCH-AQ
- 66 Bench, black, front only 66-B-BENCH-BK
- 66 Bench, blue, front only . 66-B-BENCH-BL
- 66 Bench, dark red, front only ..... 66-B-BENCH-BR

- 66 Bench, parchment, front only ..... 66-B-BENCH-PR

- 66 Bench, saddle, front only ..... 66-B-BENCH-SA

- 66 Bench, turquoise, front only ..... 66-B-BENCH-TQ

- 67 Bench, aqua, front only 67-B-BENCH-AQ
- 67 Bench, black, front only 67-B-BENCH-BK
- 67 Bench, blue, front only . 67-B-BENCH-BL

#### Front Seat Only Upholstery, Bench

- 67 Bench, dark red, front only ..... 67-B-BENCH-DR

- 67 Bench, ivy gold, front only ..... 67-B-BENCH-IG

- 67 Bench, parchment, front only ..... 67-B-BENCH-PR

- 67 Bench, saddle, front only ..... 67-B-BENCH-SA

- 68 Bench, aqua, front only 68-B-BENCH-AQ
- 68 Bench, black, front only 68-B-BENCH-BK
- 68 Bench, blue, front only . 68-B-BENCH-BL
- 68 Bench, ivy gold, front only ..... 68-B-BENCH-IG

- 68 Bench, maroon, front only ..... 68-B-BENCH-MR

- 68 Bench, nugget gold, front only ..... 68-B-BENCH-NG

- 68 Bench, parchment, front only ..... 68-B-BENCH-PR

- 68 Bench, saddle, front only ..... 68-B-BENCH-SA

- 68 Bench, turquoise, front only ..... 68-B-BENCH-TQ

### DELUXE FRONT SEAT ONLY UPHOLSTERY



These are front only seat upholstery sets for 69-73 Mustangs with deluxe interiors. Ours are the best on the market, precision

made from the same heavy duty vinyl and attention to detail originally used by Ford. Our custom colors are an exact match. Heavy 32 ounce vinyl and solid welt cord. Patterns are die cut for precision. In the case of Pony patterns, they have the same detail as the originals. Kits do not include hog rings for installation. Seat buttons sold separately.

#### Front Seat Only Upholstery, Deluxe

- 69 Deluxe, black, front only . 69-D-BUCK-BK
- 69 Deluxe, dark red, front only ..... 69-D-BUCK-DR

- 69 Deluxe, ivy gold, front only ..... 69-D-BUCK-IG

- 69 Deluxe, light blue, front only ..... 69-D-BUCK-LB

- 69 Deluxe, nugget gold, front only ..... 69-D-BUCK-NG

- 69 Deluxe, white, front only 69-D-BUCK-WT
- 70 Deluxe, black, front only . 70-D-BUCK-BK
- 70 Deluxe, blue, front only ... 70-D-BUCK-BL
- 70 Deluxe, ginger, front only . 70-D-BUCK-GI
- 70 Deluxe, ivy gold, front only ..... 70-D-BUCK-IV

- 70 Deluxe, vermilion, front only ..... 70-D-BUCK-VE

**WE PROUDLY FEATURE AUTHENTIC MUSTANG REPRODUCTIONS FROM SCOTT DRAKE ENTERPRISES!**



**Front Seat Only Upholstery, Deluxe**

70	Deluxe, white, front only	70-D-BUCK-WT
71	Deluxe, black, front only	.71-D-BUCK-BK
71	Deluxe, blue, front only ...	71-D-BUCK-BL
71	Deluxe, ginger, front only	.71-D-BUCK-GI
71	Deluxe, green, front only	.71-D-BUCK-GR
71	Deluxe, vermillion, front only	..... 71-D-BUCK-VE
71	Deluxe, white, front only	71-D-BUCK-WT
72-73	Deluxe, black, front only	.72-D-BUCK-BK
72-73	Deluxe, blue, front only ...	72-D-BUCK-BL
72-73	Deluxe, ginger, front only	.72-D-BUCK-GI
72-73	Deluxe, green, front only	.72-D-BUCK-GR
72-73	Deluxe, vermillion, front only	..... 72-D-BUCK-VE
72-73	Deluxe, white, front only	72-D-BUCK-WT

**GRANDE FRONT SEAT ONLY UPHOLSTERY**

These are front only seat upholstery sets for 69-71 Grande Mustangs. Ours are the best on the market, precision

made from the same heavy duty vinyl and attention to detail originally used by Ford. Our custom colors are an exact match. Heavy 32 ounce vinyl and solid welt cord. Patterns are die cut for precision. These all come with comfortweave inserts. Rare cloth insert option is not available. Kits do not include hog rings for installation. Seat buttons sold separately.

**Front Seat Only Upholstery, Grande**

69	Grande, black, front only	.69-G-BUCK-BK
69	Grande, dark red, front only	..... 69-G-BUCK-DR
69	Grande, ivy gold, front only	..... 69-G-BUCK-IG
69	Grande, light blue, front only	..... 69-G-BUCK-LB
69	Grande, nugget gold, front only	..... 69-G-BUCK-NG
69	Grande, white, front only	69-G-BUCK-WT
70	Grande, black, front only	.70-G-BUCK-BK
70	Grande, blue, front only ..	70-G-BUCK-BL
70	Grande, ginger, front only	70-G-BUCK-GI
70	Grande, ivy Gold, front only	..... 70-G-BUCK-IV
70	Grande, vermillion, front only	..... 70-G-BUCK-VE
70	Grande, white, front only	70-G-BUCK-WT
71	Grande, black, front only	.71-G-BUCK-BK
71-73	Grande, blue, front only ..	71-G-BUCK-BL
71-73	Grande, ginger, front only	71-G-BUCK-GI
71-73	Grande, green, front only	71-G-BUCK-GR
71-73	Grande, vermillion, front only	..... 71-G-BUCK-VE

**MACH 1 FRONT SEAT ONLY UPHOLSTERY**

These are front only seat upholstery sets for 69-73 Mach 1 Mustangs. Our upholstery sets are the best on the market,

precision made from the same heavy duty vinyl and attention to detail originally used by Ford. Our custom colors are an exact match. Heavy 32 ounce vinyl and solid welt cord. Patterns are die cut for precision. Kits do not include hog rings for installation.

**Front Seat Only Upholstery, Mach 1**

69	Mach 1, black/black stripe, front only	.... 69-M-BUCK-BK/BK
69	Mach 1, black/red stripe, front only	..... 69-M-BUCK-BK/RD
69	Mach 1, dark blue/specify stripe, front only	..... 69-M-BUCK-DB/ST
69	Mach 1, dark red/specify stripe, front only	..... 69-M-BUCK-DR/ST
69	Mach 1, white/red stripe, front only	..... 69-M-BUCK-WT/RD
69	Mach 1, white/white stripe, front only	... 69-M-BUCK-WT/WT
70	Mach 1, black/gray stripe, front only	..... 70-M-BUCK-BK/GY
70	Mach 1, dark blue/specify stripe, front only	..... 70-M-BUCK-DB/ST
70	Mach 1, dark red/specify stripe, front only	..... 70-M-BUCK-DR/ST
70	Mach 1, white/gray stripe, front only	..... 70-M-BUCK-WT/GY
70	Mach 1, white/white stripe, front only	... 70-M-BUCK-WT/WT
71-73	Mach 1, black/gray stripe, front only	..... 71-M-BUCK-BK/GR
71	Mach 1, black, front only	71-M-BUCK-BK
71	Mach 1, dark blue, front only	..... 71-M-BUCK-DB
71	Mach 1, dark red, front only	..... 71-M-BUCK-DR
71-73	Mach 1, ginger, front only	71-M-BUCK-GI
71	Mach 1, white, front only	..... 71-M-BUCK-WT
72-73	Mach 1, dark blue, front only	..... 72-M-BUCK-DB
72-73	Mach 1, dark red, front only	..... 72-M-BUCK-DR
72-73	Mach 1, white, front only	..... 72-M-BUCK-WT

**PONY FRONT SEAT ONLY UPHOLSTERY**

These are front only seat upholstery sets for 64-66 Mustangs with Pony Interiors. Ours are the best on the market, precision made from

the same heavy duty vinyl and attention to detail originally used by Ford. Our custom colors are an exact match. Heavy 32 ounce vinyl and solid welt cord. Patterns are die cut for precision. In the case of Pony patterns, they have the same detail as the originals. Kits do not include hog rings for installation.

**Front Seat Only Upholstery, Pony**

65	Pony, black, front only	.... 65-P-BUCK-BK
65	Pony, blue/white, front only	..... 65-P-BUCK-BL
65	Pony, bright red, front only	..... 65-P-BUCK-BR
65	Pony, ivy gold/white, front only	..... 65-P-BUCK-IG
65	Pony, palomino, front only	..... 65-P-BUCK-PA
65	Pony, white, front only ..	65-P-BUCK-WT
66	Pony, aqua/white, front only	..... 66-P-BUCK-AQ
66	Pony, dark red, front only	66-P-BUCK-DR
66	Pony, emberglo/parchment, front only	.. 66-P-BUCK-EM
66	Pony, parchment, front only	..... 66-P-BUCK-PR

**SPORT SEAT FRONT SEAT ONLY UPHOLSTERY**

These Sport Seats are designed to replace the original 1965-67 upholstery and combine racy looks with comfort,

performance and superior support. Available as a full upholstery set, or with front seat upholstery only. New Sport Seat foam is required (See C5ZZ6560050/1SS). Headrests are sold separately. Matching door panels are also available.

**Front Seat Only Upholstery, Sport Seat**

65-67	Sport seats, Pony, black, front only	..... SS-65-P-BUCK-BK
65-67	Sport seats, Pony, blue, front only	..... SS-65-P-BUCK-BL
65-67	Sport seats, Pony, bright red, front only	.. SS-65-P-BUCK-BR
65-67	Sport seats, Pony, ivy gold, front only	..... SS-65-P-BUCK-IG
65-67	Sport seats, Pony, palomino, front only	.. SS-65-P-BUCK-PA

**Front Seat Only Upholstery, Sport Seat**

65-67	Sport seats, Pony, red/white, front only ..	SS-65-P-BUCK-RW
65-67	Sport seats, Pony, white, front only .....	SS-65-P-BUCK-WT
65-67	Sport seats, Pony, aqua/white, front only	SS-66-P-BUCK-AQ
65-67	Sport seats, Pony, dark red, front only ....	SS-66-P-BUCK-DR
65-67	Sport seats, Pony, red/white, front only ..	SS-66-P-BUCK-RW
65-67	Sport seats, standard, aqua, front only ...	SS-67-S-BUCK-AQ
65-67	Sport seats, standard, blue, front only ....	SS-67-S-BUCK-BL
65-67	Sport seats, standard, ivy gold, front only	SS-67-S-BUCK-IG
65-67	Sport seats, standard, parchment, front only .....	SS-67-S-BUCK-PR
65-67	Sport seats, standard, saddle, front only .	SS-67-S-BUCK-SA
67	Sport seats, standard, black, front only ...	SS-67-S-BUCK-BK
69-70	Sports seat Mach 1, special order special year and colors .....	SS-69-M-BUCK-SO

**STANDARD FRONT SEAT ONLY UPHOLSTERY**



These are front only seat upholstery sets for Mustangs with standard bucket seats. Ours are the best on the market, precision

made from the same heavy duty vinyl and attention to detail originally used by Ford. Our custom colors are an exact match. Heavy 32 ounce vinyl and solid welt cord. Patterns are die cut for precision. In the case of Pony patterns, they have the same detail as the originals. Kits do not include hog rings for installation. Deluxe interior seat button sold separately for 67-68 deluxe interior.

**Front Seat Only Upholstery, Standard**

64-65	Standard, black, front only .....	65-S-BUCK-BK
64-65	Standard, blue, front only	65-S-BUCK-BL
64-65	Standard, bright red, front only .....	65-S-BUCK-BR
64-65	Standard, ivy gold, front only .....	65-S-BUCK-IG
64-65	Standard, palomino, front only .....	65-S-BUCK-PA
64-65	Standard, white, front only .....	65-S-BUCK-WT
66	Standard, aqua, front only .....	66-S-BUCK-AQ
66	Standard, black, front only .....	66-S-BUCK-BK

**Front Seat Only Upholstery, Standard**

66	Standard, blue, front only	66-S-BUCK-BL
66	Standard, dark red, front only .....	66-S-BUCK-DR
66	Standard, parchment, front only .....	66-S-BUCK-PR
67	Standard, aqua, front only .....	67-S-BUCK-AQ
67	Standard, black, front only .....	67-S-BUCK-BK
67	Standard, blue, front only	67-S-BUCK-BL
67	Standard, dark red, front only .....	67-S-BUCK-DR
67	Standard, ivy gold, front only .....	67-S-BUCK-IG
67	Standard, parchment, front only .....	67-S-BUCK-PR
67	Standard, saddle, front only .....	67-S-BUCK-SA
68	Standard, aqua, front only .....	68-S-BUCK-AQ
68	Standard, black, front only .....	68-S-BUCK-BK
68	Standard, blue, front only	68-S-BUCK-BL
68	Standard, ivy gold, front only .....	68-S-BUCK-IG
68	Standard, maroon, front only .....	68-S-BUCK-MR
68	Standard, nugget gold, front only .....	68-S-BUCK-NG
68	Standard, parchment, front only .....	68-S-BUCK-PR
68	Standard, saddle, front only .....	68-S-BUCK-SA
69	Standard, black, front only .....	69-S-BUCK-BK
69	Standard, dark red, front only .....	69-S-BUCK-DR
69	Standard, ivy gold, front only .....	69-S-BUCK-IG
69	Standard, light blue, front only .....	69-S-BUCK-LB
69	Standard, nugget gold, front only .....	69-S-BUCK-NG
70	Standard, black, front only .....	70-S-BUCK-BK
70	Standard, blue, front only	70-S-BUCK-BL
70	Standard, ginger, front only .....	70-S-BUCK-GI
70	Standard, green, front only .....	70-S-BUCK-GR
70	Standard, ivy gold, front only .....	70-S-BUCK-IV
70	Standard, vermillion, front only .....	70-S-BUCK-VE
70	Standard, white, front only .....	70-S-BUCK-WT

**Front Seat Only Upholstery, Standard**

71-73	Standard, black, front only .....	71-S-BUCK-BK
71-73	Standard, blue, front only	71-S-BUCK-BL
71-73	Standard, ginger, front only .....	71-S-BUCK-GI
71-73	Standard, green, front only .....	71-S-BUCK-GR
71-73	Standard, vermillion, front only .....	71-S-BUCK-VE
71-73	Standard, white, front only .....	71-S-BUCK-WT

**BENCH FULL SET SEAT UPHOLSTERY**



These are complete seat upholstery sets for Mustangs with a bench seat. Ours are the best on the market, precision made from

the same heavy duty vinyl and attention to detail originally used by Ford. Our custom colors are an exact match. Heavy 32 ounce vinyl and solid welt cord. Patterns are die cut for precision. In the case of Pony patterns, they have the same detail as the originals. Kits do not include hog rings for installation.

**Full Set Seat Upholstery, Bench**

65	Bench, coupe, black .....	65CP-B-FULL-BK
65	Bench, coupe, blue .....	65CP-B-FULL-BL
65	Bench, coupe, bright red .....	65CP-B-FULL-BR
65	Bench, coupe, ivy gold .....	65CP-B-FULL-IG
65	Bench, coupe, palomino .....	65CP-B-FULL-PA
65	Bench, coupe, white .....	65CP-B-FULL-WT
65	Bench, convertible, black .....	65CV-B-FULL-BK
65	Bench, convertible, blue .....	65CV-B-FULL-BL
65	Bench, convertible, bright red .....	65CV-B-FULL-BR
65	Bench, convertible, ivy gold .....	65CV-B-FULL-IG
65	Bench, convertible, palomino .....	65CV-B-FULL-PA
65	Bench, convertible, white .....	65CV-B-FULL-WT
66	Bench, coupe, aqua .....	66CP-B-FULL-AQ
66	Bench, coupe, black .....	66CP-B-FULL-BK
66	Bench, coupe, blue .....	66CP-B-FULL-BL
66	Bench, coupe, dark red .....	66CP-B-FULL-DR
66	Bench, coupe, parchment .....	66CP-B-FULL-PR
66	Bench, convertible, aqua .....	66CV-B-FULL-AQ
66	Bench, convertible, black .....	66CV-B-FULL-BK

Interior

**WE PROUDLY FEATURE AUTHENTIC MUSTANG REPRODUCTIONS FROM SCOTT DRAKE ENTERPRISES!**





**Full Set Seat Upholstery, Bench**

66	Bench, convertible, blue .....	66CV-B-FULL-BL
66	Bench, convertible, dark red .....	66CV-B-FULL-DR
66	Bench, convertible, parchment .....	66CV-B-FULL-PR
67	Bench, coupe, aqua .....	67CP-B-FULL-AQ
67	Bench, coupe, black .....	67CP-B-FULL-BK
67	Bench, coupe, blue .....	67CP-B-FULL-BL
67	Bench, coupe, dark red .....	67CP-B-FULL-DR
67	Bench, coupe, ivy gold .....	67CP-B-FULL-IG
67	Bench, coupe, parchment .....	67CP-B-FULL-PR
67	Bench, coupe, saddle .....	67CP-B-FULL-SA
67	Bench, convertible, aqua .....	67CV-B-FULL-AQ
67	Bench, convertible, black .....	67CV-B-FULL-BK
67	Bench, convertible, blue .....	67CV-B-FULL-BL
67	Bench, convertible, dark red .....	67CV-B-FULL-DR
67	Bench, convertible, ivy gold .....	67CV-B-FULL-IG
67	Bench, convertible, parchment .....	67CV-B-FULL-PR
67	Bench, convertible, saddle .....	67CV-B-FULL-SA
68	Bench, coupe, aqua .....	68CP-B-FULL-AQ
68	Bench, coupe, black .....	68CP-B-FULL-BK
68	Bench, coupe, blue .....	68CP-B-FULL-BL
68	Bench, coupe, ivy gold .....	68CP-B-FULL-IG
68	Bench, coupe, maroon .....	68CP-B-FULL-MR
68	Bench, coupe, nugget gold .....	68CP-B-FULL-NG
68	Bench, coupe, parchment .....	68CP-B-FULL-PR
68	Bench, coupe, saddle .....	68CP-B-FULL-SA
68	Bench, Fastback, aqua .....	68FB-B-FULL-AQ
68	Bench, Fastback, black .....	68FB-B-FULL-BK
68	Bench, Fastback, blue .....	68FB-B-FULL-BL
68	Bench, Fastback, ivy gold .....	68FB-B-FULL-IG
68	Bench, Fastback, maroon .....	68FB-B-FULL-MR
68	Bench, Fastback, nugget gold .....	68FB-B-FULL-NG
68	Bench, Fastback, parchment .....	68FB-B-FULL-PR
68	Bench, Fastback, saddle .....	68FB-B-FULL-SA
69	Bench, coupe, black .....	69CP-B-FULL-BK
69	Bench, coupe, dark red .....	69CP-B-FULL-DR
69	Bench, coupe, ivy gold .....	69CP-B-FULL-IG
69	Bench, coupe, light blue .....	69CP-B-FULL-LB
69	Bench, coupe, nugget gold .....	69CP-B-FULL-NG

**DELUXE FULL SET SEAT  
UPHOLSTERY**

These are complete seat upholstery sets for 68-73 Mustangs with deluxe interiors. Ours are the best on the market, precision made from the same heavy duty vinyl and attention to detail originally used by Ford. Our custom colors are an exact match. Heavy 32 ounce vinyl and solid welt cord. Patterns are die cut for precision. In the case of Pony patterns, they have the same detail as the originals. Kits do not include hog rings for installation. Seat buttons sold separately.

**Full Set Seat Upholstery, Deluxe**

67	Deluxe, Fastback, black with comfort weave .....	67FB-D-FULL-BK
68	Deluxe, Fastback, black with comfort-weave .....	68FB-D-FULL-BK
69	Deluxe, coupe, black .....	69CP-D-FULL-BK
69	Deluxe, coupe, dark red .....	69CP-D-FULL-DR
69	Deluxe, coupe, ivy gold .....	69CP-D-FULL-IG
69	Deluxe, coupe, light blue .....	69CP-D-FULL-LB
69	Deluxe, coupe, nugget gold .....	69CP-D-FULL-NG
69	Deluxe, coupe, white .....	69CP-D-FULL-WT
69	Deluxe, convertible, black .....	69CV-D-FULL-BK
69	Deluxe, convertible, dark red .....	69CV-D-FULL-DR
69	Deluxe, convertible, ivy gold .....	69CV-D-FULL-IG
69	Deluxe, convertible, light blue .....	69CV-D-FULL-LB
69	Deluxe, convertible, nugget gold .....	69CV-D-FULL-NG
69	Deluxe, convertible, white .....	69CV-D-FULL-WT
69	Deluxe, Fastback, dark red .....	69FB-D-FULL-DR
69	Deluxe, Fastback, ivy gold .....	69FB-D-FULL-IG
69	Deluxe, Fastback, light blue .....	69FB-D-FULL-LB
69	Deluxe, Fastback, nugget gold .....	69FB-D-FULL-NG
69	Deluxe, Fastback, white .....	69FB-D-FULL-WT
70	Deluxe, coupe, black .....	70CP-D-FULL-BK
70	Deluxe, coupe, blue .....	70CP-D-FULL-BL
70	Deluxe, coupe, ginger .....	70CP-D-FULL-GI
70	Deluxe, coupe, ivy gold .....	70CP-D-FULL-IV
70	Deluxe, coupe, vermillion .....	70CP-D-FULL-VE
70	Deluxe, coupe, white .....	70CP-D-FULL-WT

**Full Set Seat Upholstery, Deluxe**

70	Deluxe, convertible, black .....	70CV-D-FULL-BK
70	Deluxe, convertible, blue .....	70CV-D-FULL-BL
70	Deluxe, convertible, ginger .....	70CV-D-FULL-GI
70	Deluxe, convertible, ivy gold .....	70CV-D-FULL-IV
70	Deluxe, convertible, vermillion .....	70CV-D-FULL-VE
70	Deluxe, convertible, white .....	70CV-D-FULL-WT
70	Deluxe, Fastback, black .....	70FB-D-FULL-BK
70	Deluxe, Fastback, blue .....	70FB-D-FULL-BL
70	Deluxe, Fastback, ginger .....	70FB-D-FULL-GI
70	Deluxe, Fastback, ivy gold .....	70FB-D-FULL-IV
70	Deluxe, Fastback, vermillion .....	70FB-D-FULL-VE
70	Deluxe, Fastback, white .....	70FB-D-FULL-WT
71	Deluxe, coupe, black .....	71CP-D-FULL-BK
71	Deluxe, coupe, blue .....	71CP-D-FULL-BL
71	Deluxe, coupe, ginger .....	71CP-D-FULL-GI
71	Deluxe, coupe, green .....	71CP-D-FULL-GR
71	Deluxe, coupe, vermillion .....	71CP-D-FULL-VE
71	Deluxe, coupe, white .....	71CP-D-FULL-WT
71	Deluxe, convertible, black .....	71CV-D-FULL-BK
71	Deluxe, convertible, blue .....	71CV-D-FULL-BL
71	Deluxe, convertible, ginger .....	71CV-D-FULL-GI
71	Deluxe, convertible, green .....	71CV-D-FULL-GR
71	Deluxe, convertible, vermillion .....	71CV-D-FULL-VE
71	Deluxe, convertible, white .....	71CV-D-FULL-WT
71	Deluxe, Fastback, black .....	71FB-D-FULL-BK
71	Deluxe, Fastback, blue .....	71FB-D-FULL-BL
71	Deluxe, Fastback, ginger .....	71FB-D-FULL-GI
71	Deluxe, Fastback, green .....	71FB-D-FULL-GR
71	Deluxe, Fastback, vermillion .....	71FB-D-FULL-VE
71	Deluxe, Fastback, white .....	71FB-D-FULL-WT
72-73	Deluxe, coupe, black .....	72CP-D-FULL-BK
72-73	Deluxe, coupe, blue .....	72CP-D-FULL-BL
72-73	Deluxe, coupe, ginger .....	72CP-D-FULL-GI
72-73	Deluxe, coupe, green .....	72CP-D-FULL-GR
72-73	Deluxe, coupe, vermillion .....	72CP-D-FULL-VE
72-73	Deluxe, coupe, white .....	72CP-D-FULL-WT

**Full Set Seat Upholstery, Deluxe**

72-73 Deluxe, convertible, black .....	72CV-D-FULL-BK
72-73 Deluxe, convertible, blue .....	72CV-D-FULL-BL
72-73 Deluxe, convertible, ginger .....	72CV-D-FULL-GI
72-73 Deluxe, convertible, green .....	72CV-D-FULL-GR
72-73 Deluxe, convertible, vermillion .....	72CV-D-FULL-VE
72-73 Deluxe, convertible, white .....	72CV-D-FULL-WT
72-73 Deluxe, Fastback, black .....	72FB-D-FULL-BK
72-73 Deluxe, Fastback, blue .....	72FB-D-FULL-BL
72-73 Deluxe, Fastback, ginger .....	72FB-D-FULL-GI
72-73 Deluxe, Fastback, green .....	72FB-D-FULL-GR
72-73 Deluxe, Fastback, vermillion .....	72FB-D-FULL-VE
72-73 Deluxe, Fastback, white .....	72FB-D-FULL-WT

**GRANDE FULL SET SEAT UPHOLSTERY**



These are complete seat upholstery sets for 69-71 Grande Mustangs. Ours are the best on the market, precision

made from the same heavy duty vinyl and attention to detail originally used by Ford. Our custom colors are an exact match. Heavy 32 ounce vinyl and solid welt cord. Patterns are die cut for precision. These all come with comfortweave inserts. Rare cloth insert option is not available. Kits do not include hog rings for installation. Seat buttons sold separately.

**Full Set Seat Upholstery, Grande**

69 Grande, coupe, black .....	69CP-G-FULL-BK
69 Grande, coupe, dark red .....	69CP-G-FULL-DR
69 Grande, coupe, ivy gold .....	69CP-G-FULL-IG
69 Grande, coupe, light blue .....	69CP-G-FULL-LB
69 Grande, coupe, nugget gold .....	69CP-G-FULL-NG
69 Grande, coupe, white .....	69CP-G-FULL-WT
70 Grande, coupe, black .....	70CP-G-FULL-BK
70 Grande, coupe, blue .....	70CP-G-FULL-BL
70 Grande, coupe, ginger .....	70CP-G-FULL-GI
70 Grande, coupe, ivy gold .....	70CP-G-FULL-IG
70 Grande, coupe, vermillion .....	70CP-G-FULL-VE
70 Grande, coupe, white .....	70CP-G-FULL-WT

**Full Set Seat Upholstery, Grande**

71 Grande, coupe, black .....	71CP-G-FULL-BK
71 Grande, coupe, blue .....	71CP-G-FULL-BL
71 Grande, coupe, ginger .....	71CP-G-FULL-GI
71 Grande, coupe, green .....	71CP-G-FULL-GR
71 Grande, coupe, vermillion .....	71CP-G-FULL-VE
71 Grande, coupe, white .....	71CP-G-FULL-WT

**MACH 1 FULL SET SEAT UPHOLSTERY**



These are complete seat upholstery sets for 69-73 Mach 1 Mustangs. Our upholstery sets are the best on the market,

precision made from the same heavy duty vinyl and attention to detail originally used by Ford. Our custom colors are an exact match. Heavy 32 ounce vinyl and solid welt cord. Patterns are die cut for precision. Kits do not include hog rings for installation.

**Full Set Seat Upholstery, Mach 1**

69 Mach 1, black/black stripe .....	69M-FULL-BK/BK
69 Mach 1, black/red stripe .....	69M-FULL-BK/RD
69 Mach 1, blue/specify stripe .....	69M-FULL-DB/ST
69 Mach 1, dark red/specify stripe .....	69M-FULL-DR/ST
69 Mach 1, white/black stripe .....	69M-FULL-WT/BK
69 Mach 1, white/red stripe .....	69M-FULL-WT/RD
69 Mach 1, white/white stripe .....	69M-FULL-WT/WT
70 Mach 1, black/black stripe .....	70M-FULL-BK/BK
70 Mach 1, black/gray stripe .....	70M-FULL-BK/GY
70 Mach 1, dark blue/specify stripe .....	70M-FULL-DB/ST
70 Mach 1, dark red/specify stripe .....	70M-FULL-DR/ST
70 Mach 1, white/gray stripe .....	70M-FULL-WT/GY
70 Mach 1, white/white stripe .....	70M-FULL-WT/WT
71 Mach 1, black/silver .....	71FB-M-FULL-BS
71 Mach 1, dark blue .....	71FB-M-FULL-DB
71 Mach 1, dark red .....	71FB-M-FULL-DR
71 Mach 1, ginger .....	71FB-M-FULL-GI
71 Mach 1, green .....	71FB-M-FULL-GR
71 Mach 1, vermillion .....	71FB-M-FULL-VE
71 Mach 1, white .....	71FB-M-FULL-WT
71-73 Mach 1, black .....	71FB-M-FULL-BK

**Full Set Seat Upholstery, Mach 1**

71-73 Mach 1, black/red stripe .....	71-M-FULL-BK/RD
72-73 Mach 1, dark red .....	72FB-M-FULL-DR
72-73 Mach 1, white .....	72FB-M-FULL-WT

**PONY FULL SET SEAT UPHOLSTERY**



These are complete seat upholstery sets for 64-66 Mustangs with Pony Interiors. Ours are the best on the market, precision made from

the same heavy duty vinyl and attention to detail originally used by Ford. Our custom colors are an exact match. Heavy 32 ounce vinyl and solid welt cord. Patterns are die cut for precision. In the case of Pony patterns, they have the same detail as the originals. Kits do not include hog rings for installation.

**Full Set Seat Upholstery, Pony**

65 Pony, coupe, black/white .....	65CP-P-FULL-B/W
65 Pony, coupe, black .....	65CP-P-FULL-BK
65 Pony, coupe, blue/white .....	65CP-P-FULL-BL
65 Pony, coupe, bright red .....	65CP-P-FULL-BR
65 Pony, coupe, ivy gold/white .....	65CP-P-FULL-IG
65 Pony, coupe, palomino .....	65CP-P-FULL-PA
65 Pony, coupe, red/white .....	65CP-P-FULL-R/W
65 Pony, coupe, white .....	65CP-P-FULL-WT
65 Pony, convertible, bright red .....	65CV-P-FULL-BR
65 Pony, convertible, palomino .....	65CV-P-FULL-PA
65 Pony, convertible, bright red/white .....	65CV-P-FULL-R/W
65 Pony, convertible, white .....	65CV-P-FULL-WT
65 Pony, Fastback, red .....	65FB-P-FULL-BR
65 Pony, Fastback, palomino .....	65FB-P-FULL-PA
65 Pony, Fastback, red/white .....	65FB-P-FULL-R/W
65 Pony, Fastback, white .....	65FB-P-FULL-WT
65-66 Pony, convertible, black/white .....	65CP-P-FULL-B/W
65-66 Pony, convertible, black .....	65CV-P-FULL-BK
65-66 Pony, convertible, blue/white .....	65CV-P-FULL-BL
65-66 Pony, convertible, ivy gold/white .....	65CV-P-FULL-IG
65-66 Pony, Fastback, black/white .....	65FB-P-FULL-B/W
65-66 Pony, Fastback, black .....	65FB-P-FULL-BK
65-66 Pony, Fastback, blue/white .....	65FB-P-FULL-BL

Interior

**WE PROUDLY FEATURE AUTHENTIC MUSTANG REPRODUCTIONS FROM SCOTT DRAKE ENTERPRISES!**



**Full Set Seat Upholstery, Pony**

65-66	Pony, Fastback, ivy gold/white .....	65FB-P-FULL-IG
66	Pony, coupe, aqua/white .....	66CP-P-FULL-AQ
66	Pony, coupe, dark red ...	66CP-P-FULL-DR
66	Pony, coupe, emberglo/parchment .....	66CP-P-FULL-EM
66	Pony, coupe, parchment	66CP-P-FULL-PR
66	Pony, coupe, dark red/white .....	66CP-P-FULL-R/W
66	Pony, convertible, aqua/white .....	66CV-P-FULL-AQ
66	Pony, convertible, dark red .....	66CV-P-FULL-DR
66	Pony, convertible, emberblo/parchment .....	66CV-P-FULL-EM
66	Pony, convertible, parchment .....	66CV-P-FULL-PR
66	Pony, convertible, dark red/white .....	66CV-P-FULL-R/W
66	Pony, Fastback, aqua/white .....	66FB-P-FULL-AQ
66	Pony, Fastback, dark red	66FB-P-FULL-DR
66	Pony, Fastback, emberglo/parchment ...	66FB-P-FULL-EM
66	Pony, Fastback, parchment .....	66FB-P-FULL-PR
66	Pony, Fastback, dark red/white .....	66FB-P-FULL-R/W

**SPORT SEAT FULL SET SEAT UPHOLSTERY**

These Sport Seats are designed to replace the original 1965-67 upholstery and combine racy looks with comfort,

performance and superior support. Available as a full upholstery set, or with front seat upholstery only. New Sport Seat foam is required (See C5ZZ6560050/1SS). Headrests are sold separately. Matching door panels are also available.

**Full Set Seat Upholstery, Sport Seat**

65	Sport seats, Pony, Fastback, black .....	SS-65FB-FULL-BK
65	Sport seats, Pony, Fastback, blue .....	SS-65FB-FULL-BL
65	Sport seats, Pony, Fastback, bright red ...	SS-65FB-FULL-BR
65	Sport seats, Pony, Fastback, ivy gold .....	SS-65FB-FULL-IG
65	Sport seats, Pony, Fastback, palomino ...	SS-65FB-FULL-PA
65	Sport seats, Pony, Fastback, bright red/white .....	SS-65FB-FULL-RW

**Full Set Seat Upholstery, Sport Seat**

65	Sport seats, Pony, Fastback, white .....	SS-65FB-FULL-WT
65-67	Sport seats, Pony, coupe, black .....	SS-65CP-FULL-BK
65-67	Sport seats, Pony, coupe, blue .....	SS-65CP-FULL-BL
65-67	Sport seats, Pony, coupe, bright red .....	SS-65CP-FULL-BR
65-67	Sport seats, Pony, coupe, ivy gold .....	SS-65CP-FULL-IG
65-67	Sport seats, Pony, coupe, palomino .....	SS-65CP-FULL-PA
65-67	Sport seats, Pony, coupe, red/white .....	SS-65CP-FULL-RW
65-67	Sport seats, Pony, coupe, white .....	SS-65CP-FULL-WT
65-67	Sport seats, Pony, convertible, black .....	SS-65CV-FULL-BK
65-67	Sport seats, Pony, convertible, blue .....	SS-65CV-FULL-BL
65-67	Sport seats, Pony, convertible, bright red	SS-65CV-FULL-BR
65-67	Sport seats, Pony, convertible, ivy gold ...	SS-65CV-FULL-IG
65-67	Sport seats, Pony, convertible, palomino	SS-65CV-FULL-PA
65-67	Sport seats, Pony, convertible, red/white	SS-65CV-FULL-RW
65-67	Sport seats, Pony, convertible, white .....	SS-65CV-FULL-WT
65-67	Sport seats, Pony, coupe, aqua .....	SS-66CP-FULL-AQ
65-67	Sport seats, Pony, coupe, dark red .....	SS-66CP-FULL-DR
65-67	Sport seats, Pony, coupe, emberglo .....	SS-66CP-FULL-EM
65-67	Sport seats, Pony, coupe, parchment .....	SS-66CP-FULL-PR
65-67	Sport seats, Pony, coupe, red/white .....	SS-66CP-FULL-RW
65-67	Sport seats, Pony, convertible, aqua .....	SS-66CV-FULL-AQ
65-67	Sport seats, Pony, convertible, dark red ..	SS-66CV-FULL-DR
65-67	Sport seats, Pony, convertible, emberglo	SS-66CV-FULL-EM
65-67	Sport seats, Pony, convertible, parchment	SS-66CV-FULL-PR
65-67	Sport seats, Pony, convertible, dark red/white .....	SS-66CV-FULL-RW
65-67	Sport seats, standard, convertible, aqua .	SS-67CV-FULL-AQ
65-67	Sport seats, standard, convertible, black .	SS-67CV-FULL-BK
65-67	Sport seats, standard, convertible, blue ..	SS-67CV-FULL-BL

**Full Set Seat Upholstery, Sport Seat**

65-67	Sport seats, standard, convertible, dark red .....	SS-67CV-FULL-DR
65-67	Sport seats, standard, convertible, ivy gold .....	SS-67CV-FULL-IG
65-67	Sport seats, standard, convertible, parchment .....	SS-67CV-FULL-PR
65-67	Sport seats, standard, convertible, saddle	SS-67CV-FULL-SA
66	Sport seats, Pony, Fastback, aqua .....	SS-66FB-FULL-AQ
66	Sport seats, Pony, Fastback, dark red .....	SS-66FB-FULL-DR
66	Sport seats, Pony, Fastback, emberglo ...	SS-66FB-FULL-EM
66	Sport seats, Pony, Fastback, parchment ..	SS-66FB-FULL-PR
66	Sport seats, Pony, Fastback, dark red/white .....	SS-66FB-FULL-RW
66-67	Sport seats, standard, coupe, dark red ....	SS-67CP-FULL-DR
67	Sport seats, standard, coupe, aqua .....	SS-67CP-FULL-AQ
67	Sport seats, standard, coupe, black .....	SS-67CP-FULL-BK
67	Sport seats, standard, coupe, blue .....	SS-67CP-FULL-BL
67	Sport seats, standard, coupe, ivy gold ....	SS-67CP-FULL-IG
67	Sport seats, standard, coupe, parchment	SS-67CP-FULL-PR
67	Sport seats, standard, coupe, saddle .....	SS-67CP-FULL-SA
67	Sport seats, standard, Fastback, aqua ....	SS-67FB-FULL-AQ
67	Sport seats, standard, Fastback, black ....	SS-67FB-FULL-BK
67	Sport seats, standard, Fastback, blue .....	SS-67FB-FULL-BL
67	Sport seats, standard, Fastback, dark red	SS-67FB-FULL-DR
67	Sport seats, standard, Fastback, ivy gold	SS-67FB-FULL-IG
67	Sport seats, standard, Fastback, parch-ment .....	SS-67FB-FULL-PR
67	Sport seats, standard, Fastback, saddle ..	SS-67FB-FULL-SA
69-70	Sports seats Mach 1, special order special year and colors .....	SS-69-M-FULL-SO

## STANDARD FULL SET SEAT UPHOLSTERY



These are complete seat upholstery sets for Mustangs with standard bucket seats. Ours are the best on the market, precision

made from the same heavy duty vinyl and attention to detail originally used by Ford. Our custom colors are an exact match. Heavy 32 ounce vinyl and solid welt cord. Patterns are die cut for precision. In the case of Pony patterns, they have the same detail as the originals. Kits do not include hog rings for installation. Deluxe interior seat button sold separately for 67-68 deluxe interior.

### Full Set Seat Upholstery, Standard

64-65	Standard, coupe, black	.65CP-S-FULL-BK
64-65	Standard, coupe, blue	..65CP-S-FULL-BL
64-65	Standard, coupe, bright red	.....65CP-S-FULL-BR
64-65	Standard, coupe, ivy gold	.....65CP-S-FULL-IG
64-65	Standard, coupe, palomino	.....65CP-S-FULL-PA
64-65	Standard, coupe, white	65CP-S-FULL-WT
64-65	Standard, convertible, black	.....65CV-S-FULL-BK
64-65	Standard, convertible, blue	.....65CV-S-FULL-BL
64-65	Standard, convertible, bright red	.....65CV-S-FULL-BR
64-65	Standard, convertible, ivy gold	.....65CV-S-FULL-IG
64-65	Standard, convertible, palomino	.....65CV-S-FULL-PA
64-65	Standard, convertible, white	.....65CV-S-FULL-WT
65	Standard, Fastback, black	.....65FB-S-FULL-BK
65	Standard, Fastback, blue	.....65FB-S-FULL-BL
65	Standard, Fastback, bright red	.....65FB-S-FULL-BR
65	Standard, Fastback, ivy gold	.....65FB-S-FULL-IG
65	Standard, Fastback, palomino	.....65FB-S-FULL-PA
65	Standard, Fastback, white	.....65FB-S-FULL-WT
66	Standard, coupe, aqua	.66CP-S-FULL-AQ
66	Standard, coupe, black	.66CP-S-FULL-BK
66	Standard, coupe, blue	..66CP-S-FULL-BL
66	Standard, coupe, dark red	.....66CP-S-FULL-DR
66	Standard, coupe, parchment	.....66CP-S-FULL-PR

### Full Set Seat Upholstery, Standard

66	Standard, convertible, aqua	.....66CV-S-FULL-AQ
66	Standard, convertible, black	.....66CV-S-FULL-BK
66	Standard, convertible, blue	.....66CV-S-FULL-BL
66	Standard, convertible, dark red	.....66CV-S-FULL-DR
66	Standard, convertible, parchment	.....66CV-S-FULL-PR
66	Standard, Fastback, aqua	.....66FB-S-FULL-AQ
66	Standard, Fastback, black	.....66FB-S-FULL-BK
66	Standard, Fastback, blue	.....66FB-S-FULL-BL
66	Standard, Fastback, dark red	.....66FB-S-FULL-DR
66	Standard, Fastback, parchment	.....66FB-S-FULL-PR
67	Standard, coupe, aqua	.67CP-S-FULL-AQ
67	Standard, coupe, black	.67CP-S-FULL-BK
67	Standard, coupe, blue	..67CP-S-FULL-BL
67	Standard, coupe, dark red	.....67CP-S-FULL-DR
67	Standard, coupe, ivy gold	.....67CP-S-FULL-IG
67	Standard, coupe, parchment	.....67CP-S-FULL-PR
67	Standard, coupe, saddle	67CP-S-FULL-SA
67	Standard, convertible, aqua	.....67CV-S-FULL-AQ
67	Standard, convertible, black	.....67CV-S-FULL-BK
67	Standard, convertible, blue	.....67CV-S-FULL-BL
67	Standard, convertible, dark red	.....67CV-S-FULL-DR
67	Standard, convertible, ivy gold	.....67CV-S-FULL-IG
67	Standard, convertible, parchment	.....67CV-S-FULL-PR
67	Standard, convertible, saddle	67CV-S-FULL-SA
67	Standard, Fastback, aqua	.....67FB-S-FULL-AQ
67	Standard, Fastback, black	.....67FB-S-FULL-BK
67	Standard, Fastback, blue	.....67FB-S-FULL-BL
67	Standard, Fastback, dark red	.....67FB-S-FULL-DR
67	Standard, Fastback, ivy gold	.....67FB-S-FULL-IG
67	Standard, Fastback, parchment	.....67FB-S-FULL-PR

### Full Set Seat Upholstery, Standard

67	Standard, Fastback, saddle	.....67FB-S-FULL-SA
68	Standard, coupe, aqua	.68CP-S-FULL-AQ
68	Standard, coupe, black	.68CP-S-FULL-BK
68	Standard, coupe, blue	..68CP-S-FULL-BL
68	Standard, coupe, ivy gold	.....68CP-S-FULL-IG
68	Standard, coupe, maroon	.....68CP-S-FULL-MR
68	Standard, coupe, nugget gold	.....68CP-S-FULL-NG
68	Standard, coupe, parchment	.....68CP-S-FULL-PR
68	Standard, coupe, red/white	.....68CP-S-FULL-R/W
68	Standard, coupe, saddle	68CP-S-FULL-SA
68	Standard, convertible, aqua	.....68CV-S-FULL-AQ
68	Standard, convertible, black	.....68CV-S-FULL-BK
68	Standard, convertible, blue	.....68CV-S-FULL-BL
68	Standard, convertible, ivy gold	.....68CV-S-FULL-IG
68	Standard, convertible, maroon	.....68CV-S-FULL-MR
68	Standard, convertible, nugget gold	.....68CV-S-FULL-NG
68	Standard, convertible, parchment	.....68CV-S-FULL-PR
68	Standard, convertible, saddle	68CV-S-FULL-SA
68	Standard, Fastback, aqua	.....68FB-S-FULL-AQ
68	Standard, Fastback, black	.....68FB-S-FULL-BK
68	Standard, Fastback, blue	.....68FB-S-FULL-BL
68	Standard, Fastback, ivy gold	.....68FB-S-FULL-IG
68	Standard, Fastback, maroon	.....68FB-S-FULL-MR
68	Standard, Fastback, nugget gold	.....68FB-S-FULL-NG
68	Standard, Fastback, parchment	.....68FB-S-FULL-PR
68	Standard, Fastback, saddle	68FB-S-FULL-SA
69	Standard, coupe, black	.69CP-S-FULL-BK
69	Standard, coupe, dark red	.....69CP-S-FULL-DR
69	Standard, coupe, ivy gold	.....69CP-S-FULL-IG
69	Standard, coupe, light blue	.....69CP-S-FULL-LB

**WE PROUDLY FEATURE AUTHENTIC MUSTANG REPRODUCTIONS FROM SCOTT DRAKE ENTERPRISES!**



**Full Set Seat Upholstery, Standard**

69	Standard, coupe, nugget gold .....	69CP-S-FULL-NG
69	Standard, coupe, white	69CP-S-FULL-WT
69	Standard, convertible, black .....	69CV-S-FULL-BK
69	Standard, convertible, dark red .....	69CV-S-FULL-DR
69	Standard, convertible, ivy gold .....	69CV-S-FULL-IG
69	Standard, convertible, light blue .....	69CV-S-FULL-LB
69	Standard, convertible, nugget gold .....	69CV-S-FULL-NG
69	Standard, convertible, white .....	69CV-S-FULL-WT
69	Standard, Fastback, black .....	69FB-S-FULL-BK
69	Standard, Fastback, dark red .....	69FB-S-FULL-DR
69	Standard, Fastback, ivy gold .....	69FB-S-FULL-IG
69	Standard, Fastback, light blue .....	69FB-S-FULL-LB
69	Standard, Fastback, nugget gold .....	69FB-S-FULL-NG
70	Standard, coupe, black	70CP-S-FULL-BK
70	Standard, coupe, blue ..	70CP-S-FULL-BL
70	Standard, coupe, ginger	70CP-S-FULL-GI
70	Standard, coupe, ivy gold .....	70CP-S-FULL-IV
70	Standard, coupe, vermilion .....	70CP-S-FULL-VE
70	Standard, coupe, white	70CP-S-FULL-WT
70	Standard, convertible, black .....	70CV-S-FULL-BK
70	Standard, convertible, blue .....	70CV-S-FULL-BL
70	Standard, convertible, ginger .....	70CV-S-FULL-GI
70	Standard, convertible, ivy gold .....	70CV-S-FULL-IV
70	Standard, convertible, vermilion .....	70CV-S-FULL-VE
70	Standard, convertible, white .....	70CV-S-FULL-WT
70	Standard, Fastback, black .....	70FB-S-FULL-BK
70	Standard, Fastback, blue .....	70FB-S-FULL-BL
70	Standard, Fastback, ginger .....	70FB-S-FULL-GI
70	Standard, Fastback, ivy gold .....	70FB-S-FULL-IV
70	Standard, Fastback, vermilion .....	70FB-S-FULL-VE
70	Standard, Fastback, white .....	70FB-S-FULL-WT

**Full Set Seat Upholstery, Standard**

70	Standard, Fastback, white .....	70FB-S-FULL-WT
71	Standard, coupe, vermilion .....	71CP-S-FULL-VE
71	Standard, convertible, black .....	71CV-S-FULL-BK
71	Standard, convertible, blue .....	71CV-S-FULL-BL
71	Standard, convertible, ginger .....	71CV-S-FULL-GI
71	Standard, convertible, green .....	71CV-S-FULL-GR
71	Standard, convertible, vermilion .....	71CV-S-FULL-VE
71	Standard, convertible, white .....	71CV-S-FULL-WT
71-73	Standard, coupe, black	71CP-S-FULL-BK
71-73	Standard, coupe, blue ..	71CP-S-FULL-BL
71-73	Standard, coupe, ginger	71CP-S-FULL-GI
71-73	Standard, coupe, green	71CP-S-FULL-GR
71-73	Standard, coupe, white	71CP-S-FULL-WT
71-73	Standard, Fastback, black .....	71FB-S-FULL-BK
71-73	Standard, Fastback, blue .....	71FB-S-FULL-BL
71-73	Standard, Fastback, ginger .....	71FB-S-FULL-GI
71-73	Standard, Fastback, green .....	71FB-S-FULL-GR
71-73	Standard, Fastback, vermilion .....	71FB-S-FULL-VE
71-73	Standard, Fastback, white .....	71FB-S-FULL-WT

**FLO-FIT CUSTOM SEAT**



The ultimate in comfort and safety without sacrificing that classic look. Flo-Fit is a leader in seating technology so you can be assured of the highest quality seats on the market. All new Flo-Fit frames and seat foams Special adapter plate for easy installation. Fully assembled in OEM colors. Authentic pony inserts. Adjustable head rest for safety and comfort. Adjustable leg extension. Improved lumbar & thigh support Side Bolsters with fully reclining backrest.

**Seat, Flo-Fit Custom**

64-73	High-back, Pony, black .....	FF-P-BK
64-73	High-back, Pony, blue/white ....	FF-P-BL
64-73	High-back, Pony, bright red .....	FF-P-BR
64-73	High-back, Pony, bright red/white .....	FF-P-BR/W
64-73	High-back, Pony, dark red .....	FF-P-DR
64-73	High-back, Pony, dark red/white .....	FF-P-DR/W

**Seat, Flo-Fit Custom**

64-73	High-back, Pony, ivy gold/white .	FF-P-IG
64-73	High-back, Pony, palomino .....	FF-P-PA
64-73	High-back, Pony, parchment ....	FF-P-PR
64-73	High-back, Pony, white .....	FF-P-WT

**SEAT CUSHION**



Replace your old worn out seat cushions. Excellent reproductions made from the same type of foam as the originals.

**Seat Cushion**

64-66	Standard .....	C5ZZ-6560050/1S
65-66	Pony .....	C5ZZ-6560050/1P
67	Standard/deluxe .....	C7ZZ-6560050/1S
68	Standard/deluxe .....	C8ZZ-6560050/1S
69	Lowback, standard ....	C9ZZ-6560050/1S
69-70	Highback, Mach 1, Shelby .....	C9ZZ-6560050/1M
70	Highback, standard ..	D0ZZ-6560050/1S
71-73	Highback, All .....	D1ZZ-6560050/1S

**SEAT WARMER**



Now available from Scott Drake! You can now have the same comfort of your new car, in your classic

Mustang. Kit does one seat and features two 11"x22" pads, high and low settings, trimmable so one size fits all, even heat distribution, and an 8 ft long switch harness.

64-73	.....	ACC-SW
-------	-------	--------

**SPORT SEAT SEAT CUSHION**



These seat cushions feature larger upper and lower side bolsters for more comfort and to keep you firmly planted in your seat.

Must be used in conjunction with TMI's sport seat upholstery.

**Seat Cushion, Sport Seat**

65-67	Sport seat .....	C5ZZ6560050/1SS
69-70	Highback, sport .....	C9ZZ6560050/1SS

**SEAT UPHOLSTERY BOLSTER SET**



Great time saver! Originals are usually all bent up and rusty making them difficult to install in new upholstery kits.

**Seat Upholstery Bolster Set**  
64-66 Standard 4 piece .....C5ZZ-63667A00-S

**REAR SEAT CUSHION**



Now available for 1965-70 Fastbacks. Set includes top hump and bottom cushions.

**Seat Cushion, Rear**  
65-70 Fastback, 3-piece set ..C5ZZ-6360080/32  
65-70 Fastback, rear seat bottom .....  
.....C5ZZ-6360080-B

**SHIFTER COMPONENTS**

**AFTERMARKET CLUTCH PEDAL**



These clutch pedals feature an improved design (removable pin) for easier installation. Compatible with existing hanger

assembly even in automatics.

**Clutch Pedal, Aftermarket**  
65-66 with removable pin .....C6ZZ-7519-AR  
67-68 with removable pin .....C7ZZ-7519-AR  
69-70 with removable pin .....C9ZZ-7519-B  
71-73 with removable pin .....D1ZZ-7519-B

**CLUTCH PEDAL**



Exact reproductions of the originals. Made in the U.S.A.

**Clutch Pedal**  
65-66 6 and 8 cylinder .....C6ZZ-7519-A  
67-68 6 and 8 cylinder, requires minor modification for 68 .....C7ZZ-7519-A

**CLUTCH PEDAL BUMPER**

This rubber bumper installs into the clutch pedal. Helps prevent "clunk" when pedal returns back, and properly aligns clutch pedal height.

**Clutch Pedal Bumper**  
 67-68  
C7Z-7583

**Clutch Pedal Bumper**



69-70  
D0ZZ-7583

**CLUTCH PEDAL STOP**



Good copy of original, fabric web cushion.

**Clutch Pedal Stop**  
64-66 .....C20Z-7A630-A

**SHIFT BOOT RETAINER**

These pieces really dress up the area around the shifter.

**Shift Boot Retainer**

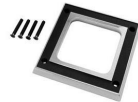

64-68: Chrome, Deluxe, 3 and 4 speed, without console \*Rare Original Option\*  
C4ZB-7262-B

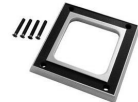

64-68: Satin, Deluxe, 3 and 4 speed, without console  
C4ZB-7262-S



64-68: Chrome, manual transmission without console  
C5ZZ-7262-C



69-70: Chrome, manual transmission  
C9ZZ-7262-C

**SHIFTER SELECTOR LEVER**



Factory detailing and triple chrome plating distinguish our tubular shift handles from the rest. Cable and T-lever included. American

made for quality workmanship.

**Shifter Selector Lever**  
65-67 4-speed .....C5ZZ-7210-M  
65-67 5-speed .....C5ZZ-7210-T  
68 4-speed .....C8ZZ-7210-A

**GENUINE LEATHER SHIFTER BOOT**



These leather shift boots look great! Our 64-73 boots feature draw string at the neck and rubber insulated metal mounting plate.

**Shifter Boot, Genuine Leather**  
64-68 Leather with draw string ...C5ZZ-7277-L

**Shifter Boot, Genuine Leather**

69-73 Leather with draw string ...C9ZZ-7277-L

**LOWER SHIFTER BOOT**



This rubber boot mounts on the shifter housing underneath the shift boot. Most cars are missing this important part. It was

designed to keep dirt and moisture out of the shifter box and reduce noise coming through the shifter hole. An excellent reproduction.

**Shifter Boot, Lower**

65-68 3 speed .....C6ZZ-7138-B  
65-68 4 speed, small block .....C6ZZ-7138-C  
69 4 speed .....C9ZZ-7138-B  
70 4 speed hurst .....D0GZ-7138

**RUBBER SHIFTER BOOT**



An exact copy of the original. Compression molded E.P.D.M. rubber. Features a textured skin that matches the original

appearance exactly. Ours has a steel insert just like the originals.

**Shifter Boot, Rubber**

64-68 3 and 4 speed .....C5ZZ-7277-B  
69-70 3 and 4 speed .....C9ZZ-7277-A  
70 Hurst, 4 speed .....D0ZZ-7277-B

**AUTOMATIC SHIFT LEVER**



Beautiful chrome plating. Fully assembled with shift cable and locking pawl.

**Shifter Selector Lever**

64-68 64-66: All / 67-68: without console .....  
C5ZZ-7210-A  
69-73 69-73: All .....C9ZZ-7210-A

**SHIFTER ASSEMBLY**



This is a complete shifter including the reverse lock out mechanism. Great chrome and sturdy construction.

**Shifter Assembly**

67-68 Console cars only .....C7ZZ-7210-KIT

**SHIFTER BEZEL AND KNOB KIT**



Includes shift knob, bezel, new bushings and mounting hardware. Without factory console.

**Shifter Bezel and Knob Kit**

64-66 .....KIT-TRN-1

Interior

**WE PROUDLY FEATURE AUTHENTIC MUSTANG REPRODUCTIONS FROM SCOTT DRAKE ENTERPRISES!**



149

**Shifter Bezel and Knob Kit**

67-68 .....KIT-TRN-2

**AUTOMATIC SHIFT PLATE ASSEMBLY**

Precision stamped steel construction, painted black, includes shift dial, selector slide and proper hardware.

**Automatic Shift Plate Assembly**

65-66 ..... C5ZZ-7D350-K

**CONSOLE SHIFT SIDE SEAL**

Die cut from a tough, wear resistant material which matches the original. Automatic transmissions only.

**Console Shift Side Seal**

64-66 .....C5ZZ-7C445-A

67-68 .....C7ZZ-7C445-A

**CONSOLE SHIFTER SELECTOR ROD**

This is the rod that connects the shifter to the indicator in the console for automatic transmissions.

**Console Shifter Selector Rod**

67-68 .....C7ZZ-7E148-A

**SHIFTER BUTTONS****Shifter Buttons**

64-73 Black ..... C5ZZ-7C488-C

68-71 Chrome plated, Left hand C80Z-7C488-A

69-73 Black .....C9ZZ-7C488-C

**SHIFTER COVER ASSEMBLY**

Quality chrome finish over zinc die cast. Features correct details and paint. Seal &amp; Dial included.

**Shifter Cover Assembly**

64 Concours, without arrows .. C4ZZ-7D394

65-66 Concours ..... C5ZZ-7D394

67-68 Not exact copy ..... C7ZZ-7D394

67-68 Concours ..... C7ZZ-7D394-P

**Shifter Cover Assembly**

69-70 Concours, will also fit 1971-73 for an upgraded look ..... C9ZZ-7D394

**SHIFTER BEZEL****Shifter Bezel**

71 ..... D1ZZ-7D443-A

**SHIFTER DIAL**

Precision molded clear plastic with black or clear background under red arrows and white letters.

**Shifter Dial**

64 Early 64, Black, no arrows, non-console . C4ZZ-7A213-A

64-66 Black, for center console . C5ZZ-7A213-D

65-66 Black, non-console ..... C5ZZ-7A213-A

67-68 Black, non-console ..... C7ZZ-7A213-A

69-70 Clear, no arrows, All .....C9ZZ-7E271-A

**DELUXE SHIFTER HANDLE**

Originally used for the deluxe interior of the Grande and Mach 1's but will fit all 64-73 cars.

**Shifter Handle**

67-68 Parchment, deluxe ..... C80Z-7213-PR

67-68 Saddle, deluxe ..... C80Z-7213-SA

67-69 Dark blue, deluxe ..... C80Z-7213-BL

67-73 Black, deluxe ..... C80Z-7213-BK

67-73 Black, leather, deluxe ....C80Z-7213-BKL

68-69 Maroon, deluxe ..... C80Z-7213-MR

**SHIFTER HANDLE****Shifter Handle**

64-73 Chrome, concours .....C5ZZ-7213-F

**Shifter Handle**

69-73 Chrome, concours .....C90Z-7213-B

**AUTOMATIC TRANSMISSION****SHIFTER SEAL**

High quality rubber molded around a flexible steel insert. Insert is cadmium plated to prevent rust.

**Shifter Seal, Automatic Transmission**

64-68 Non-console ..... C5ZZ-7D351

69-73 All .....D1ZZ-7D351-A

**STEERING****GRANT HORN BUTTON**

Optional button to customize your Grant steering wheel. Only fits 1170 wood

wheels.

**Grant Horn Button**

64-73 Horn button, fits 1170 and 1175\* .. 5668

64-73 Grant 966 wheel\* ..... 5847

64-73 Chrome\* ..... 5875

65-73 Ford blue\* ..... 5665

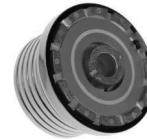
**GRANT HUB KIT**

These kits are fully assembled for easy installation and are available in either a highly polished mirror finish or anodized in

deep, black luster finish. Fits 1170 and 1175 wheels only.

**Grant Hub Kit**

68-73 Black ..... 5249

68-73 Highly polished ..... 5249-1

**GRANT STEERING WHEEL**

Aluminum frame aftermarket steering wheel with Mustang center emblem on horn center. 15 inch.

**Grant Steering Wheel**64-73: Mahogany, 14 w/ polished alum spokes and rivets  
1175 .....64-73: Wood, 13 1/2 w/ brushed s/s spokes  
96364-73: Wood, 15 w/ brushed s/s spokes\*  
966 .....

**Grant Steering Wheel**



65-73: Mahogany, 14 1/2 w/ polished alum spokes  
1170



65-73: Black foam, 15 w/ brushed s/s spokes\*  
968

**GRANT STEERING WHEEL ADAPTER**

Mounting and contact adapter required for each Grant wheel.

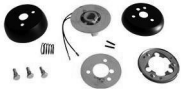

**Grant Steering Wheel Adapter**

64	3285
65-67	3294
68-73	3249

**GRANT TILT COLUMN ADAPTER**

Special adapter required to run Grant steering wheels on a Flaming River tilt column. Replaces 3294 & 3249 adapters. Will not work with Corso Ferocce steering wheels.



**Grant Tilt Column Adapter**

65-70	CSZZ-3514-GMA
-------	---------------

**HORN BUTTON RUBBER SPRING PAD**



This is the OE rubber pad that is typically smashed in the horn button.

**Horn Button Rubber Spring Pad**

64-67	CODZ-13A813-A
-------	---------------

**HORN PANEL BEZEL**

Plastic injection and chrome plated. Fits in center of steering wheel, holds vinyl pad and buttons.



**Horn Panel Bezel**

68-69	C8ZZ-3D572-AR
-------	---------------

**HORN PANEL BEZEL BUTTON**

Chromed Plastic buttons with textured black centers. Set of 6.



**Horn Panel Bezel Button**

68-69 Set of 6	C8ZZ-3600-AR
----------------	--------------

**HORN PANEL PAD**

Vinyl pad available in black only.

**Horn Panel Pad**



68-69: Black, standard interior	C8AZ-3629-A
---------------------------------	-------------



69: Deluxe	C9ZZ-3623
------------	-----------



70-73: Black	D0ZZ-3623-A
--------------	-------------



70-73: Black, standard	D0ZZ-13915
------------------------	------------



71-73: Black, deluxe	D1ZZ-13915
----------------------	------------

**HORN RING BUTTON**



Excellent concours reproduction. Diecast construction features acrylic



plastic center emblem, chrome plated main assembly and painted recesses. 64-66 fully assembled and ready to install. Horn spring not included, order part # CODZ-13A807-B.

**Horn Ring Button**

64 Standard, generator, concours, 3 spoke *	CSZZ-13A805-C
65-66 Standard, alternator, concours, 3 spoke *	CSZZ-13A805-B
65-67 Deluxe, for wood wheel, no emblem, 3 spoke	C7OZ-13A805-ER
67 Standard, no emblem, 3 spoke	C7ZZ-13A805-A
68-69 Standard, no emblem, 2 spoke	C9AZ-13A805-B

**HORN RING CENTER PAD**



Soft padded urethane. Not painted but molded urethane so color will not



wear off. Features our chrome trim ring and center emblem.

**Horn Ring Center Pad**

67 Aqua*	C7ZZ-3623-AQ
67 Black*	C7ZZ-3623-BK
67 Blue*	C7ZZ-3623-BL
67 Ivy Gold*	C7ZZ-3623-IG
67 Parchment*	C7ZZ-3623-PR
67 Red*	C7ZZ-3623-RD
67 Saddle*	C7ZZ-3623-SA

**HORN SWITCH**



**Horn Switch**

70-73	D2AZ-13875
-------	------------

**RIM BLOW HORN SWITCH**

The switch that goes inside the rim of the steering wheel to actuate the horn.

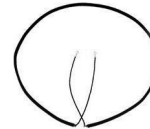

**Horn Switch, Rim Blow**

69	C9AZ-13A875-C
70-73	D1AZ-13A875-A

**HORN SWITCH TRIM PLATE**

Wood grain plate for deluxe 2 spoke wheel.



**Horn Switch Trim Plate**

69 Deluxe	C9ZZ-3752
71-73 Wood grain	D1ZZ-13932

**CORSO FEROCCE COBRA EMBLEM**



This fits the horn button to change center emblem to Cobra or Mustang.

**Corso Ferocce Cobra Emblem**

65-73 Cobra, chrome plated w/ metal medalion <sup>§</sup>	S1MS-3649-C
---	-------------

Interior

**WE PROUDLY FEATURE AUTHENTIC MUSTANG REPRODUCTIONS FROM SCOTT DRAKE ENTERPRISES!**



151



### Corso Feroce Cobra Emblem

65-73 Running horse tribar emblem .....  
C7ZZ-65044A90-M

### CORSO FEROCO COLUMN ADAPTER



Hub to adapt the Corso Feroce steering wheels. Now with adjustable collar. Required to mount Corso Feroce wheel.

### Corso Feroce Column Adapter

64-66 Billet ..... S1MS-3511-P  
67-73 Billet ..... S7MS-3511-P

### CORSO FEROCO HORN BUTTON



Horn button for Corso Feroce steering wheel, has two wire connectors.

### Corso Feroce Horn Button

65-73 Double connector ..... S1MS-3623-A

### CORSO FEROCO STEERING WHEEL

A beautiful wheel and the perfect choice for a Shelby look a like. These wheels are handcrafted with pride. Adapter and horn button sold separately.

### Corso Feroce Steering Wheel



65-73: Genuine leather, 15 inch  
S1MS-3600-BK



65-73: Genuine wood, 15 inch  
S1MS-3600-WG

### STANDARD STEERING WHEEL



Molded in hard plastic, wheel feature nice details, a new wheels really brings the interior together.

### Steering Wheel, Standard

64 Black, generator ..... C4ZZ-3600-BK  
64 Blue, generator ..... C4ZZ-3600-BL  
64 Palamino, generator ..... C4ZZ-3600-PA  
64 Red, generator ..... C4ZZ-3600-RD  
64 White, generator ..... C4ZZ-3600-WT  
65 Blue ..... C5ZZ-3600-BL

### Steering Wheel, Standard

65 Bright red ..... C5ZZ-3600-BR  
65-66 Black ..... C5ZZ-3600-BK  
65-66 Palamino and parchment C5ZZ-3600-PA  
65-66 White ..... C5ZZ-3600-WT  
66 Aqua ..... C6ZZ-3600-AQ  
66 Dark red ..... C6ZZ-3600-DR  
66 Light blue ..... C6ZZ-3600-LB  
66 Parchment ..... C6ZZ-3600-PR  
67 Black ..... C7ZZ-3600-BK  
67 Blue ..... C7ZZ-3600-BL  
67 Dark red ..... C7ZZ-3600-DR  
67 Ivy Gold ..... C7ZZ-3600-IG  
67 Parchment ..... C7ZZ-3600-PR  
68-69 Black ..... C8ZZ-3600-BK  
68-69 Blue ..... C8ZZ-3600-BL  
68-69 Dark red ..... C8ZZ-3600-DR  
68-69 Ivy Gold ..... C8ZZ-3600-IG

### DELUXE STEERING WHEEL ASSEMBLY



Reproduction of Pony interior simulated wood wheel. Includes horn ring, contact plates and hardware. This wheel was also

optional on standard interior cars, and original equipment on 66 Shelybs. Horn center cap sold separately.

### Steering Wheel Assembly, Deluxe

65-66 Woodgrain, assembly .... C5ZZ-3600-NK  
65-66 Woodgrain, wheel only, for pony interior C5ZZ-3600-N  
67 Woodgrain, assembly .... C70Z-3600-NK

### STEERING WHEEL CENTER



Deluxe wheel only. Pressure die cast with quality chrome plating. Includes lens,

rim, spring steel snap ring.

### Steering Wheel Center

65-66 Concours\* ..... C5ZZ-3623-A  
65-66 Economy\* ..... C5ZZ-3623-AR  
66 Shelby, U.S.A. S ..... S2MS-3623-A

### STEERING WHEEL COLLAR



Mounts on bottom of original deluxe wheel. Die cast construction like original. Concours plating.

### Steering Wheel Collar

65-66 ..... C5ZZ-3491-A  
67 ..... C70Z-3491-A

### STEERING WHEEL EMBLEM



The most authentic and best looking emblems available.

### Steering Wheel Emblem



67: Running horse\*  
C7ZZ-3649-A



68: Running horse\*  
C8ZZ-3649-AR



68: Shelby Cobra<sup>S</sup>  
S8MS-3649-A



69-70: Shelby Cobra<sup>S</sup>  
C9MS-3649-A



69-73: For use on 2-spoke wheel  
C9ZZ-3649-S

### DELUXE 3-SPOKE STEERING WHEEL EMBLEM



Features ABS injection with a crystal clear lens, and a highly detailed Mustang logo.

This is the center emblem for 3-spoke style, 1969 Mustang steering wheels.

### Steering Wheel Emblem, Deluxe 3-spoke

69 For 1969 3-spoke style steering wheel\* ..  
C9ZZ-3649-B

70-73 \* ..... D0ZZ-3649

### STEERING WHEEL HUB AND EMBLEM TRIM



Great kit for complete steering wheel restoration.

### Steering Wheel Hub and Emblem Trim

67 \* ..... C7ZZ-3649/56-K

### STEERING WHEEL HUB TRIM



This is the chrome trim ring that goes on the steering wheel hub. 4 3/8" diameter.

Steering Wheel Hub Trim  
67 ..... C7Z-3656-A

### STEERING WHEEL UPPER COLLAR



Steering Wheel Upper Collar  
67 Deluxe ..... C7OZ-3656-A

### LOWER STEERING COLUMN COVER



A very nice reproduction of a commonly broken part.

Lower Steering Column Cover  
69 ..... C9Z-6504459-BK  
70 ..... D0ZZ-6504459-BK  
71-73 ..... D1ZZ-6504459

### FLAMING RIVER TILT STEERING COLUMN



Available in paintable steel or polished stainless steel. Requires mounting kit. Will fit 1970 cars but relocation of ignition

switch is required. These fit original steering boxes only. Modifications required to 64-67E shaft. Original versions have original Ford splines to accept factory wheels. The below Tilt Steering Columns are for use with factory steering boxes only and are not to be used with rack & pinion kits. Rack & pinion kits are available as a Special Order, add "-RP" to the end of the appropriate part number below. Prices are the same provided it can be added to our next stocking order, otherwise additional freight charges will apply.

#### Tilt Steering Column, Flaming River

65-66 For Grant wheels only ... CSZ-3514-AFT  
65-66 For Grant wheel, stainless steel ..... CSZ-3514-AFT-S  
65-66 For original wheel ..... CSZ-3514-OEM  
67-69 For Grant wheels only ... C7Z-3514-AFT  
67-69 For Grant wheel, stainless steel ..... C7Z-3514-AFT-S

#### Tilt Steering Column, Flaming River

67-69 For original wheel ..... C7Z-3514-OEM

### IDIDIT TILT STEERING COLUMN



ididit introduces the first Ford Top Shaft and Ford Turn Signal Switch tilt steering column for 1965-69 Mustangs! This

made to fit column will include a special new floor mount, 8-position tilt, Mustang style knobs & handles and male & female plugs with terminals. ididit's new Mustang column will accept a stock Mustang steering wheel or an aftermarket wheel with an adaptor. By using the stock underdash mount and a coupler (sold separately), the installation is a breeze! The new 8-position tilt 1965-69 Mustang column is available in Paintable Steel, Chrome and Black Powder Coated. Lower shaft is 3/4" 36. Don't forget your installation kit, each installation kit from ididit is specific to your Mustang application. Each ididit column is 100% American Made. Note: 65-67E require cutting original shaft. The below part numbers are for use with stock steering boxes. For Rack and Pinion add "-RP" which are available as a Special Order.

#### Tilt Steering Column, ididit

65-66 Black ..... CSZ-3514-B  
65-66 Chrome ..... CSZ-3514-C  
65-66 Paintable steel ..... CSZ-3514-S  
67 Black ..... C7Z-3514-B  
67 Chrome ..... C7Z-3514-C  
67 Paintable steel ..... C7Z-3514-S  
68-69 Black ..... C8Z-3514-B  
68-69 Chrome ..... C8Z-3514-C  
68-69 Paintable steel ..... C8Z-3514-S

### FLAMING RIVER TILT STEERING COLUMN MOUNT KIT



This kit includes all components to install a Flaming River tilt column.

#### Tilt Steering Column Mount Kit, Flaming River

65-67 ..... CSZ-3514-MK  
67-70 ..... C7Z-3514-MK

### IDIDIT TILT STEERING COLUMN MOUNT KIT



These kits include the components needed to install your ididit Tilt Steering Column. Without Rack and Pinion.

#### Tilt Steering Column Mount Kit, ididit

65-67 ..... CSZ-3514-IK  
67-68 ..... C7Z-3514-IK  
69 ..... C9Z-3514-IK

## KEYS, LOCKS & LATCHES

### DOOR & IGNITION LOCKS

#### DOOR HANDLE SHAFT ASSEMBLY



Gold cadmium plated to resist rust and corrosion. Rod retainers not included.

#### Door Handle Shaft Assembly

64-66 Standard, Right hand .. CSZ-6521818-C  
64-66 Standard, Left hand .... CSZ-6521819-C  
65-66 Pony, right hand ..... CSZ-6521818-B  
65-66 Pony, left hand ..... CSZ-6521819-B  
67-68 Right hand ..... C6OZ-6221818-B  
67-68 Left hand ..... C6OZ-6221819-B

#### DOOR LATCH ASSEMBLY



Finally an affordable reproduction is available. Steel stamped complete latch.

#### Door Latch Assembly

65-66 Right hand ..... C4SZ-6321812-C  
65-66 Left hand ..... C4SZ-6321813-C  
67-68 Right hand ..... C6OZ-6221812-A  
67-68 Left hand ..... C6OZ-6221813-A  
69-70 Right hand ..... C9AZ-6221812-A  
69-70 Left hand ..... C9AZ-6221813-A  
71-73 Right hand ..... D3OZ-6521812-A  
71-73 Left hand ..... D3OZ-6521813-A

### DOOR LATCH LOCK ROD



Set of three Door Lock Rods. Zinc plated for years of service.

#### Door Latch Lock Rod

- 65-66 Left hand, set of 3 ..... C5ZZ-65213452LH
- 65-66 Right hand, set of 3 ... C5ZZ-65213452RH
- 67-68 Left hand, set of 3 ..... C7ZZ-65213452LH
- 67-68 Right hand, set of 3 ... C7ZZ-65213452RH

### DOOR LATCH PLATE REPAIR KIT



Easily repairs cracked door latch mounting holes. Includes mounting screws.

#### Door Latch Plate Repair Kit

- 64-66 ..... C5ZZ-6528160/1A
- 67-68 ..... C7ZZ-6528160/1A

### DOOR LATCH RETAINER BUSHING



Door Latch Retainer Bushing. 4 piece kit.

#### Door Latch Retainer Bushing

- 64-66 ..... C4SZ-6321801-C

### DOOR LATCH ROD CONTROL SET



This convenient rod kit does both doors. Includes zinc plated rods, door lock rod clips, and all necessary mounting hardware.

#### Door Latch Rod Control Set

- 67-68 ..... C7ZZ-6521940-KT
- 69-70 ..... C9ZZ-6521940-KT

### DOOR LATCH ROD RETAINER

This is the original, concours type door rod retainer that connect the four rods to the latch and lock assemblies inside the doors. There are six of these used in each door. Concours version offers a longer lasting and more secure fit than economy versions.

#### Door Latch Rod Retainer



64-66: Concours  
C3AZ-6221952-BR



65-66: Economy replacement  
C3AZ-6221952-A

#### Door Latch Rod Retainer



67-73: Concours  
C5AZ-6221952-AR EA

### DOOR LOCK CYLINDER RETAINER



#### Door Lock Cylinder Retainer

- 67-80 ..... C5AZ-6222023-A

### DOOR LOCK KNOB

Made by Plastic injection. Sold as a pair. Available in chrome or satin chrome.

#### Door Lock Knob



64-66: Chrome  
C5DZ-6221850-A



64-66: Satin chrome  
C5DZ-6221850-S



67: Chrome  
C5AZ-6221850-A



68-73: Chrome  
C8AZ-6221850-A

### DOOR LOCK KNOB GROMMET

The grommet that goes around the door lock knob, comes in clear, chrome or stainless.

#### Door Lock Knob Grommet



64-70: 65-68 All, 69-73 Standard interior: Clear plastic  
C5DZ-6221999-B



65-73: 65-68 All, 69-73 Standard interior: Chrome  
C5DZ-6221999-C



69-73: Stainless steel, deluxe interior  
D0DZ-6221999-AR

### DOOR STRIKER ASSEMBLY

Original factory type striker. Includes attaching parts.

#### Door Striker Assembly

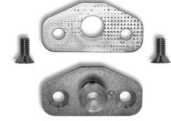

64-66: Gold zinc, Date coded 1-65  
C20Z-6222008-B



67-70: Silver zinc, date coded 8-66  
C5AZ-6222008-A



71-80: Silver zinc  
D2AZ-6522008-A

### DOOR STRIKER PLATE SCREW



Four gold cadmium plated screws to attach door strikers to 1964 through 1970 Mustangs.

#### Door Striker Plate Screw

- 64-70 Set of 4 ..... 378428-S

### IGNITION CYLINDER AND KEYS



Our ignition lock sets are all new. Two keys included.

#### Ignition Cylinder And Keys

- 64-66 ..... C50Z-11582-A
- 67-69 ..... C9AZ-11582-A
- 71-73 ..... D2AZ-11582-B
- 73-76 ..... D4AZ-11582-A

### IGNITION BEZEL TOOL



Don't scratch that new bezel or freshly painted dash with a screw driver. A dedicated tool made by Scott Drake.

Ignition Bezel Tool  
67-68 ..... T-100-YL

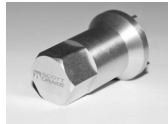

69 Ignition Bezel Tool  
T-109-CL

### IGNITION SWITCH BEZEL

A perfect reproduction with concours chrome. Ignition Switch Bezel



64-66  
C3AZ-11584-A



67-68  
C60Z-11584-A



69  
C9AZ-11584-A

### IGNITION SWITCH RETAINER

A "must have" part when installing an ignition switch. Zinc plated for years of service. Ignition Switch Retainer



64-66  
C4DZ-10A885-A



67-68  
C7ZZ-11A590-B

### DOOR LOCK KIT



These door lock cylinders assure your customers of a durable part and a perfect fit. Available in pairs only.

Lock Kit, Door  
67-73 ..... D2AZ-6521984-A

### DOOR & IGNITION LOCK KIT



Convenient matched kits save costly locksmith work. Kits include a pair of door lock cylinders and an ignition cylinder.

Comes with two keys. 1967 - 1969 include door cylinder gaskets.

#### Lock Kit, Door & Ignition

64-66 Standard keys ..... C5DZ-6222050-A  
65-66 Pony keys ..... C5DZ-6222050-B  
67-69 ..... C9AZ-6222050-A  
70-73 ..... D2AZ-6222050-A

### DOOR, IGNITION AND TRUNK LOCK KIT



#### KIT

Our quality lock set with all locks keyed the same. No separate trunk lock key.

#### Lock Kit, Door, Ignition And Trunk

67-69 ..... C7AZ-6222050-MK

### MULTIPLE DOOR & IGNITION LOCK KITS



Multiple Mustang owners, simplify your life with these matched sets for either 2 or 3 cars. 1 single key will start up to 3

cars and open 6 doors. No more grabbing the wrong keys or fumbling through multiple keys trying to open a door or start a car. You also don't need to worry about a spare. These kits come with either 4 or 6 matched keys. So there is plenty for all the family to have one and a hidden key as well.

#### Lock Kits, Multiple Door & Ignition

64-66 2 cars ..... C5DZ-6222050-2  
64-66 3 cars ..... C5DZ-6222050-3  
67-69 2 cars ..... C9AZ-6222050-2  
67-69 3 cars ..... C9AZ-6222050-3

### GLOVEBOX LOCK & COMPONENTS

#### GLOVEBOX LATCH



All new tooling was created to produce our glovebox latches. These are very nice. Also available as a locking version with

keys.

#### Glovebox Latch

64-65 Standard, curved glove box door ..... C5ZZ-6506072-A

#### Glovebox Latch

65-66 Deluxe, flat glove box door ..... C5ZZ-6506072-B  
67-68 Standard ..... C6DZ-6506072-A  
69-70 Standard ..... C9ZZ-6506072-A

### LOCKABLE GLOVEBOX LATCH



A great optional accessory from Scott Drake. All new tooling was created to produce our glovebox latches. Includes 2

matching keys.

#### Glovebox Latch, Lockable

64-65 Standard, curved door ..... C5ZZ-6506072-AL  
65-66 Deluxe, flat door ..... C5ZZ-6506072-BL  
67-68 Standard ..... C6DZ-6506072-AL  
69-70 Standard ..... C9ZZ-6506072-AL

### GLOVEBOX STRIKER KIT



Exact reproduction of the original. Hardware included. Also available in bright Chrome Finish.

#### Glovebox Striker Kit

64-66 Zinc ..... C5ZZ-6506064-A  
64-66 Chrome ..... C5ZZ-6506064-C

### GLOVEBOX AND TRUNK LOCK KIT



New from Scott Drake. All new tooling was created to produce our glovebox latches. This kit allows the use of one key for the

glovebox and trunk lock.

#### Lock Kit, Glovebox And Trunk

67-68 ..... C6DZ-6506072-K  
69-70 ..... C9ZZ-6506072-K

### HOOD LOCKS & PINS

#### HOOD LOCK BRACKET



California Special Hood Lock Bracket. Stamped steel construction. Sold individually.

#### Hood Lock Bracket

68 California Special ..... C8ZZ-16934-A

WE PROUDLY FEATURE AUTHENTIC MUSTANG REPRODUCTIONS FROM SCOTT DRAKE ENTERPRISES!



## HOOD PIN KIT

Classic hood pins and all hardware needed to install them.

### Hood Pin Kit



64-73: With cables, all stainless steel  
CSZZ-16892-SSK

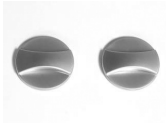

64-73: Faux, stick-on  
C8ZZ-16C896-F



64-73: Without cables  
S1MS-16892-A



64-73: With cables  
S1MS-16892-DLX



64-73: Billet, w/ cables  
S1MS-16892-K



67: With cables, Shelby  
S7MS-16892-A



69: Mach 1  
C90Z-16700-A

## HOOD TWIST LOCK

Beautiful chrome handle that is turned to lock the hood down.



### Hood Twist Lock



68: Shelby and California Special  
C8ZZ-16C896-A



69-70: Shelby®  
S9MS-16C892-A



70: Chrome  
D0ZZ-16C896-A

## Hood Twist Lock



71-73: Ram Air  
D1ZZ-16896

## HOOD TWIST LOCK CATCH



This is the catch for the twist lock. This is the catch for the twist lock. Mounts to radiator support.

### Hood Twist Lock Catch

70-73 ..... D0ZZ-16894

## HOOD TWIST LOCK RETAINER



Retainer that mounts to the bottom side of hood to accept the hood lock.

### Hood Twist Lock Retainer

70-73 ..... D0ZZ-16712

## KEYS

### KEY

\* Little touches make a big difference. These blanks have the correct Ford script or running horse.

### Key



64-66: Pony, ignition and door\*  
CSZZ-6522053-B



64-66: Pony, trunk and glovebox\*  
CSZZ-6543562-B



67-73: Standard, ignition and door\*  
C7AZ-6222053-A



67-73: Pony, ignition and door\*  
C7AZ-6222053-H



67-73: Standard, trunk and glovebox\*  
C7AZ-6243562-A

## Key



67-73: Pony, trunk and glovebox\*  
C7AZ-6243562-H

## TRUNK LOCKS

### ELECTRIC TRUNK RELEASE KIT



We combined the classic look of the original remote trunk release with a chrome release lever and a strong electric

solenoid driven latch with a modern micro switch release. Now, with a light finger pull the trunk lid opens. No cables to stretch or corrode. Simple 30 minute installation with no modifications to the car. All mounting hardware and connectors are included. Fits Coupe, Fastback and Convertible.

### Electric Trunk Release Kit

64-66 ..... C5AZ-6243200-EL

67-70 ..... C7AZ-6243200-EL

### TRUNK LATCH

Heavy duty steel stamped construction with a bright zinc plated finish

### Trunk Latch



64-66  
C20Z-6243200-B



67-73  
C5AZ-6243200-A

### TRUNK LATCH STRIKER



Exact detail made from heavy gauge steel. 65-66 available in silver zinc or bright chrome. 67-70 painted black.

### Trunk Latch Striker

64-66 Zinc ..... C40B-6243252

64-66 Chrome ..... C40B-6243252-C

67-68 Black ..... C7ZZ-6243252

69-70 Black ..... C9ZZ-6243252

### TRUNK LOCK CYLINDER



Our trunk cylinders are an exact copy, but the keys are a replacement type. Also available with Pony keys. 67-73 includes gasket and

retainer.

**Trunk Lock Cylinder**

- 64-66 Standard keys .....C50Z-6243505-B
- 64-66 Pony keys .....C50Z-6243505-P
- 67-73 Standard keys .....C7AZ-6243505-B

**TRUNK LOCK CYLINDER SLEEVE**



Pressure die cast with show car chrome. Comes with nut, washer and gasket.

**Trunk Lock Cylinder Sleeve**

- 64-66 .....C5Z-6543603-B

**TRUNK LOCK HOUSING SPACER**



Stamped steel housing spacer that attaches behind chrome trunk housing. Zinc plated.

**Trunk Lock Housing Spacer**

- 64-66 .....C5Z-6543565-A

**TRUNK LOCK STEM EXTENSION**



Exact reproductions of the originals for a perfect fit and the right look. Not included with trunk lock cylinders.

**Trunk Lock Stem Extension**

- 64-66 Concours .....C5Z-6543283-A
- 67-68 Concours .....C7Z-6543283-AR
- 69-73 Economy, must cut to fit .....C7Z-6543283-A

**TRUNK RELEASE**



High quality chrome with improved cable. Includes chrome base, lever cable, and all mounting hardware.

**Note: 67-70 release only**

*works on cars that come factory equipped with this option.*

*All others refer to electronic version.*

**Trunk Release**

- 64-66 All .....C4AZ-62432A00-A
- 67-70 Factory equipped only .....C7AZ-62432A00-A

**WIRELESS TRUNK RELEASE**



Designed for use with our Electric Trunk Release Kits (above). Easy to install and adds modern convenience. Includes two wireless

remotes.

**Trunk Release, Wireless**

- 65-70 .....C5Z-6243200-WR

**LITERATURE**

**ASSEMBLY MANUALS**

**BODY ASSEMBLY MANUAL**

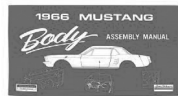

This manual shows how to attach all body components and gives you the actual Ford part numbers for the hardware needed.

**Manual, Body Assembly**

- 64 .....AM-1
- 65 .....AM-6
- 66 .....AM-11
- 67 .....AM-16
- 68 .....AM-21
- 69 .....AM-26
- 70 .....AM-31
- 71-72 .....AM-41
- 73 .....AM-46

**CHASSIS ASSEMBLY MANUAL**



This book shows every aspect of the steering, suspension, exhaust and all other chassis components as well as hardware.

**Manual, Chassis Assembly**

- 64-65 .....AM-5
- 67 .....AM-20
- 68 .....AM-25
- 69 .....AM-30
- 70 .....AM-35
- 73 .....AM-50

**CONVERTIBLE TOP REPAIR MANUAL**



The convertible top is the most complicated part of any car. This manual features complete top adjustments, servicing,

electrical and trouble-shooting.

**Manual, Convertible Top Repair**

- 64-66 .....MP-14

**ELECTRICAL ASSEMBLY MANUAL**



This Electrical Assembly Manual features detailed drawings and schematics of the electrical system. Very

easy to read.

**Manual, Electrical Assembly**

- 64 .....AM-3
- 65 .....AM-8
- 66 .....AM-13
- 67 .....AM-18
- 68 .....AM-23
- 69 .....AM-28
- 70 .....AM-33
- 71-72 .....AM-43

**ENGINE COMPONENT ASSEMBLY MANUAL**



**Manual, Engine Component Assembly**

- 64 .....AM-154
- 65 .....AM-155
- 66 .....AM-156
- 67 .....AM-157
- 69 .....AM-159

**EXPLODED VIEW ILLUSTRATION MANUAL**



Shows all Ford illustrations, easy to read, great for seeing how assemblies fit together. Also lists basic part numbers.

**Manual, Exploded View Illustration**

- 64-65 .....MP-309
- 66 .....MP-347
- 67-68 .....MP-313
- 69-70 .....MP-348

**INTERIOR ASSEMBLY MANUAL**



This manual is perfect for showing the proper placement of each interior component. From headliner to carpet and even the

Ford part numbers for the attaching hardware, this book has it all.

**Manual, Interior Assembly**

- 64 .....AM-2
- 65 .....AM-7
- 66 .....AM-12
- 67 .....AM-17
- 68 .....AM-22
- 70 .....AM-32

**WE PROUDLY FEATURE AUTHENTIC MUSTANG REPRODUCTIONS FROM SCOTT DRAKE ENTERPRISES!**



**Manual, Interior Assembly**  
71-72 .....AM-37

### SHOP MANUAL



A must for anyone planning to work on their own car. This is an easy sell when your customers start looking through the

wealth of information contained in these books. All books contain detailed instructions on disassembly and assembly of all major components as well as frame squaring specs.

#### Manual, Shop

64 Supplement .....	MP-27
64 .....	SM-64
65 .....	SM-65
66 .....	SM-66
67 .....	SM-67
68 .....	SM-68
69 .....	SM-69
70 .....	SM-70
71 .....	SM-71
72 .....	SM-72
73 .....	SM-73

### TILT -A- WAY COLUMN REPAIR AND DIAGNOSTIC MANUAL



**Manual, Tilt -a- Way Column Repair And Diagnostic**  
67-69 Tilt-A-Way ..... MP-310

### VACUUM SCHEMATIC MANUAL



Saves time and frustration! Shows schematic and diagrams that reveal the location and function of the many

vacuum systems on Mustangs and Shelbys.

#### Manual, Vacuum Schematic

67 Mustang and Shelby .....	MP-150
68 Mustang and Shelby .....	MP-151
69 Mustang and Cougar .....	MP-152
70 Mustang and Cougar .....	MP-153
71 Mustang and Cougar .....	MP-154
72 Mustang and Cougar .....	MP-155
73 Mustang and Cougar .....	MP-156

### WELD-SEALANT MANUAL



Anyone doing a total restoration and wanting to do it correctly needs this manual. While showing proper

drawings of every sheet metal part, it also illustrates where Ford put sealant and anti-rattle material as well as the proper Ford part numbers for them.

#### Manual, Weld-Sealant

64 .....	AM-9
67 .....	AM-19
68 .....	AM-24
70 .....	AM-34
71-72 .....	AM-39

### WIRING DIAGRAM MANUAL



Covers a multitude of electrical pictorial diagrams, color codes are listed, plus easy to follow schematics.

#### Wiring Diagram Manual

64 .....	MP-312
65 .....	MP-1
66 .....	MP-2
67 .....	MP-3
68 .....	MP-4
69 .....	MP-5
70 .....	MP-6
71 .....	MP-7
72 .....	MP-8
73 .....	MP-9

### LARGE FORMAT WIRING DIAGRAM MANUAL



Covers a multitude of electrical pictorial diagrams, color codes are listed, plus easy to follow schematics. Our large format features

larger diagrams that are easier to read.

#### Wiring Diagram Manual, Large Format

64 .....	MP-311-P
65 .....	MP-1-P
66 .....	MP-2-P
67 .....	MP-3-P
68 .....	MP-4-P
69 .....	MP-5-P
70 .....	MP-6-P
71 .....	MP-7-P
72 .....	MP-8-P
73 .....	MP-9-P

## GENERAL LIBRARY

### ACCESSORY PRICE GUIDE



These neat little booklets show original cost of options and accessories. Used by dealers to figure out cost for special order

cars.

#### Accessory Price Guide

65 .....	DF-55
66 .....	DF-56
67 Shelby .....	DF-257
67 .....	DF-97
68 Shelby .....	DF-258
68 .....	DF-98
69 .....	DF-99
69-70 Shelby .....	DF-259
70 .....	DF-100
71 .....	DF-101
72 .....	DF-102
73 .....	DF-103

### BOSS 302 CHASSIS MODIFICATIONS



Reprints of original Ford brochures. Great for beefing up the Boss 302. Approximately 30 pages each. Soft bound.

#### Boss 302 Chassis Modifications

69-70 .....MP-11

### BOSS 302 ENGINE MODIFICATIONS



Reprints of original Ford brochures. Great for beefing up the Boss 302. Approximately 30 pages each. Soft bound.

#### Boss 302 Engine Modifications

69-70 .....MP-10

### BOSSSES: 302, 351, 429



Spans from 1969 - 2012. Covers specs, features, construction and much more. Copies from original sales literature. 30

pages. Soft bound.

#### Bosses: 302, 351, 429

69-71 .....MP-25



Most detailed Boss 302 book available. Covers all aspects of 1969-70 and 2011-2012 including racing history.

#### Bosses: 302, 351, 429

69-2012 .....L-71

**MUSTANG RECOGNITION GUIDE**



A full 226-pages of the Mustang history year by year. Hundreds of color photographs. A detailed study of interior and exterior.

Also includes Shelby and California special pages. Soft bound.

64-73 ..... L-69

**FORD HIGH PERFORMANCE PARTS IDENTIFIER**



Now it's easy to authenticate any high performance engine. Describes casting, numbers on engines, engine components,

transmission, and differential. 88 pages. Also features information on building and restoring a 289 HiPo. By Robert Winkelman.

**Ford High Performance Parts Identifier**  
63-73 ..... L-68

**FORDS OF THE SIXTIES**

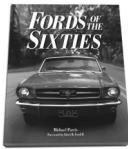

Another one of California Bill's automotive handbooks by Michael Parris. Over 175 pages filled with great shots

of the Classic Mustang and Fords from the 60's. There are even some cars that we've never seen before. Foreword by Edsel B. Ford. A Great edition to the auto enthusiast's library. Soft cover.

**Fords Of The Sixties**  
60-69 ..... 136338AE

**HIGH PERFORMANCE PARTS**



This 38 page paperback booklet covering big block modification for power and performance. Also has a listing of

Autolite-Ford Hi-Per parts available through Ford and Lincoln-Mercury dealers.  
**High Performance Parts**  
61-80 .....MP-42

**HOW TO PAINT YOUR MUSTANG**



This is a step by step procedure manual designed for first time painters. Discusses cleaning, disassembly, body preparation,

painting techniques, equipment, reassembly,

paint codes and stripes.

**How To Paint Your Mustang**  
64-73 .....L-70

**351M, 400, 429 AND 460 HOW TO REBUILD YOUR FORD 8 CYLINDER**



This book covers all the necessary steps in rebuilding a long block.

**How To Rebuild Your Ford 8 Cylinder, 351M, 400, 429 and 460**  
64-73 .....HP-36

**HOW TO REBUILD YOUR FORD BIG BLOCK**



This book covers all the necessary steps in rebuilding a long block.

**How To Rebuild Your Ford Big Block**  
67-73 .....HP-708

**HOW TO REBUILD YOUR SMALL BLOCK FORD ENGINE**

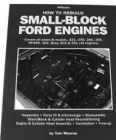

This book covers all the necessary steps in rebuilding a long block.

**How To Rebuild Your Small Block Ford Engine**  
64-73 .....HP-89

**HOW TO RESTORE YOUR MUSTANG**



Good fundamental ground up guide, showing step by step procedures for 1965 - 1968 Mustangs. This has been the best seller for several years. Easy to read, shows numerous photographs. Also contains color charts for exterior, upholstery, convertible tops, vinyl tops, and carpet.

**How To Restore Your Mustang**  
65-68 .....L-61

**HOW TO RESTORE YOUR MUSTANG:: 1964 - 1973**



This restorer's manual provides clear, concise information in an easy-to-follow format for restoring your car. In addition, it includes

information to keep the restorer on track and the project within budget. The book includes

step-by-step restoration procedures so owners and restorers can confidently complete each job. 192 pages, and includes more than 400 color photos.

**How To Restore Your Mustang:: 1964 - 1973**  
64-73 .....SA-165

**THE MUSTANG AND COUGAR TAGBOOK**



This book has everything you need to know for deciphering the codes on all the mysterious tags found on your

Mustang or Cougar (1965-73 Models).  
**Mustang and Cougar Tagbook, The**  
65-73 .....MB-102

**MUSTANG FACT BOOK**



Originally printed to provide Fords sales force with adequate product knowledge. Today's usage is numerous. Contains

information on production, performance, economy, competition, accessories and prices.  
**Mustang Fact Book**

64	.....MP-291
65	.....MP-292
66	.....MP-293
67	.....MP-294
68	.....MP-295
69	.....MP-296
69	.....MP-297
71	.....MP-298
72	.....MP-299
73	.....MP-300

**VOLUME 1 MUSTANG HOW TO**



This is Vol. 1 of a two part series. Contains 25 'How To' instruction articles. You'll find answers and instructions to the

25 most asked Mustang questions. 'How To' improve handling, repair leaking cowl panels, remedy sloppy shifters, replace a convertible top, and 'How To' replace a headliner, plus much, much more.

**Mustang How To, Volume 1**  
64-73 .....L-72

**VOLUME 2 MUSTANG HOW TO**



This is Vol. 2 of the ever popular 'How To' instruction articles. Talks about the following: rebuild a toploader, install a

**WE PROUDLY FEATURE AUTHENTIC MUSTANG REPRODUCTIONS FROM SCOTT DRAKE ENTERPRISES!**





Rally Pac, add front disc brakes, replace vinyl tops, replace carpet, plus much, much more.  
**Mustang How To, Volume 2**  
 64-73 ..... L-74

**MUSTANG BY THE NUMBERS  
 MUSTANG PRODUCTION BOOK**



Mustangs by the numbers. This new book features production facts on the 1967 - 1973 Mustang. The author

obtained the entire production database from the Ford Motor Company under license. This book contains over 12,000 statistics. Did you know only 1 1967 fastback was painted Diamond Green?  
**Mustang Production Book, Mustang By The Numbers**  
 67-73 ..... MB-101

**MUSTANG RESTORATION  
 HANDBOOK**



Great overall coverage of entire vehicle. Features articles on history, how to buy used, disassembly, suspension, steering,

brakes, engine, body, paint, interior, convertible top plus much more. 176 pages, 500 illustrations. Soft bound.  
**Mustang Restoration Handbook**  
 65-70 ..... HP-029

**MUSTANG RESTORATION TIPS AND  
 TECHNIQUES**



Compiled from Hot Rod Magazine. Features lots of how to's, sheet metal repairs, doors, interiors, flares, engine

blueprinting, transmissions, suspension swaps, buying used, rust & dent repairs plus painting. 163 pages, 100+ illustrations. Soft bound.  
**Mustang Restoration Tips And Techniques**  
 64-73 ..... 111084AE

**POCKET SIZE DATA PLATE  
 DECODER**



It's easy to use, and pocket size. Perfect for checking patent data plates and warranty number plate. Covers 1965 - 1973.

**Pocket Size Data Plate Decoder**  
 65-73 ..... L-64

**OWNERS MANUALS**

**OWNERS MANUAL**



Exact reprint of the original manual right down to the paper texture.

<b>Owners Manual</b>	
64	.....OM-64
65	.....OM-65
65	Shelby .....OM-65-S
66	.....OM-66
66	With High Performance Engine .....OM-66-HP
66	Shelby .....OM-66-S
67	.....OM-67
67	Shelby .....OM-67-S
68	.....OM-68
68	Shelby .....OM-68-S
69	.....OM-69
69	Boss 429 .....OM-69-B
69	Shelby .....OM-69-S
70	.....OM-70
70	Boss 429 .....OM-70-B
70	Shelby .....OM-70-S
71	Ford car .....OM-71
71	Mustang supplement .....OM-71-SS
71	Boss 351 .....OM-71-B
72	.....OM-72
73	.....OM-73

**OWNERS MANUAL WALLET**



Protection for your owners manual. Blue vinyl.

<b>Owners Manual Wallet</b>	
64-73 *	.....ACC-OMW
<b>Retail Catalog, Scott Drake Mustang Parts</b>	
64-73	Without pricing .....RC-WOP-B
64-73	With pricing .....RC-WP-A

**MIRRORS**

**INSIDE REAR VIEW  
 MIRRORS**

**INSIDE REAR VIEW MIRROR  
 BRACKET**



Special cast-metal bracket glues to windshield. Plain finish. Exact detail. Fits the original arm.

<b>Inside Rear View Mirror Bracket</b>	
68-69	.....C8AZ-17698-A
70-79	.....C9AZ-17698-A

**INSIDE REAR VIEW MIRROR**

Exact copies, with all the right details. Improved mirror with superior quality crimping of frame to glass. Chrome plated or black back just like originals.  
**Inside Rear View Mirror**



64-65: Day/Night push button.  
 CSZZ-17700-B



64-66: Show quality. Polished Stainless Steel.  
 CSZZ-17700-A



65-66: Day/Night turn button  
 C6ZZ-17700-A



67: Day/Night  
 C7ZZ-17700-A



68-69: Day/Night, concours  
 C7AZ-17700-GE



68-70: Day/Night, aftermarket  
 C8AZ-17700-A

**INSIDE REAR VIEW MIRROR  
ADHESIVE**



Remounts rearview mirror bracket to windshield permanently. Mounting strength is 300 psi. Unaffected by

hot and cold temperature variation. Supplied in 0.04 ounce tube.

**Inside Rear View Mirror Adhesive**

64-73 .....PRO-61067

**INSIDE REAR VIEW MIRROR AND  
ARM KIT**



Save money with this quite attractive new kit. Includes standard mirror and our pressure die cast arm.

**Inside Rear View Mirror And Arm Kit**

64-66 .....KIT-MIR-1

**INSIDE REAR VIEW MIRROR ARM**

Pressure die cast, with quality chrome. Replaces one of the most visible interior parts on a Mustang.

**Inside Rear View Mirror Arm**



64-66: Concours chrome  
CSZ-17690-D



67: Concours 2-piece design  
C7Z-17690-A



68-69: Satin  
C2SZ-17690-F

**OUTSIDE MIRRORS**

**64-66 OUTSIDE MIRROR**



These outside mirrors feature flawless chrome and a perfect fit. Mirrors fit both left and right hand side, but we recommend

our mirrors with convex glass for the right hand side because they have a greater field of vision. All mirrors come with base pad and mounting screws. Also available Economy Imported version.

**Outside Mirror, 64-66**

64-66 Chrome, economy ..... C3RZ-17696-A

**Outside Mirror, 64-66**

64-66 Chrome, show-quality ... C3RZ-17696-R

64-66 Chrome, convex, RH .....C3RZ-17696-C

**64-66, SATIN CHROME OUTSIDE  
MIRROR**



These outside mirrors feature our smooth, satin chrome finish! Our satin chrome finish is a great compliment to billet aluminum.

Match these with our satin chrome door handles for a custom look. Mirrors fit both left and right hand side, but we recommend our mirrors with convex glass for the right hand side because they have a greater field of vision. All mirrors come with base pad and mounting screws.

**Outside Mirror, 64-66, Satin Chrome**

64-66 .....C3RZ-17696-RS

64-66 Convex, RH .....C3RZ-17696-CS

**67-73 OUTSIDE MIRROR**



These outside mirrors feature flawless chrome and a perfect fit. Mirrors fit both left and right hand side, but we recommend

our mirrors with convex glass for the right hand side because they have a greater field of vision. All mirrors come with base pad and mounting screws.

**Outside Mirror, 67-73**

67-73 Chrome, long base, concours .....  
C7AZ-17696-A

67-73 Chrome, convex, long base, RH, concours  
C7AZ-17696-C

70-73 Chrome, short base ..... D1ZZ-17696-A

**67-73, SATIN CHROME OUTSIDE  
MIRROR**



These outside mirrors feature our smooth, satin chrome finish! Our satin chrome finish is a great compliment to billet aluminum.

Match these with our satin chrome door handles for a custom look. Mirrors fit both left and right hand side, but we recommend our mirrors with convex glass for the right hand side because they have a greater field of vision. All mirrors come with base pad and mounting screws.

**Outside Mirror, 67-73, Satin Chrome**

67-73 .....C7AZ-17696-AS

**Outside Mirror, 67-73, Satin Chrome**

67-73 Convex, RH .....C7AZ-17696-CS

**OUTSIDE MIRROR BASE PAD**



Black molded plastic which has a bead around perimeter just like the original.

**Outside Mirror Base Pad**

64-66 .....C3RZ-17724-A

64-66 Remote .....CSZ-17724-A

65-66 Shelby bullet .....S1MS-17724

67-68 .....C7Z-17724-A

69-70 Racing .....C9ZZ-17724-A

71-73 Racing .....D1ZZ-17724

**OUTSIDE MIRROR MOUNTING KIT**



These simple kits are an easy solution to oversized screw holes (or missing nuts on 67-73 Mustangs).

**Outside Mirror Mounting Kit**

64-66 Standard .....C3RZ-17696-MK

64-66 Remote .....CSZ-17696-MK

67-73 All .....C7AZ-17696-MK

**RACING MIRROR**



Show car quality, made in America. Exact copy of Rotunda mirror offered years ago. Includes pads, mounting hardware

'64-'68

and positioning templates.

**Racing Mirror**

64-68 Bullet, show-quality ..... CSRZ-17696-A

64-68 Bullet Imported .....CSRZ-17696-AS

64-68 Bullet, show quality, convex .....  
CSRZ-17696-B

64-68 Bullet, long base Imported .....  
CSRZ-17696-AL

64-68 Bullet, long base, convex Imported .....  
CSRZ-17696-ALC

**RACING MIRROR**



These are beautiful copies of the early style racing mirror with remote controls.

**Racing Mirror**

69 Early 69 .....C9ZZ-17696-C

69-70 Late 69, left hand .....C9ZZ-17696-L

69-70 Right hand .....C9ZZ-17696-R

71-73 Remote, left hand .....D1ZZ-17696-L

71-73 Right hand .....D1ZZ-17696-R

**WE PROUDLY FEATURE AUTHENTIC MUSTANG  
REPRODUCTIONS FROM SCOTT DRAKE ENTERPRISES!**



**REMOTE CONTROL MIRROR**



Super quality mirror by Scott Drake. These are superior to anything on the market. Features the highest quality chrome finish.

Pad and mounting hardware included. Made in the U.S.A. with pride. Show quality. Also available with convex glass for improved view.

- Remote Control Mirror**  
 64-66 Left hand, economy, imported ..... CSZZ-17696-A  
 64-66 Left hand, concours ..... CSZZ-17696-BR  
 64-66 Left hand, Rotunda logo, Concours Show-quality ..... CSZZ-17696-LR



- Remote Control Mirror**  
 67-68 Left hand, economy, imported ..... C7AZ-17696-E  
 67 Left hand, concours ..... C7AZ-17696-ER  
 67 Left hand, convex ..... C7AZ-17696-ERC  
 68 Left hand, concours ..... C8AZ-17696-ER



- Remote Control Mirror**  
 64-66 RH, convex, "dummy remote" ..... CSZZ-17696-CR  
 64-66 RH, show-quality, "dummy remote" ..... CSZZ-17696-R  
 64-66 RH, show-quality, "dummy remote" ..... CSZZ-17696-R  
 64-66 RH, convex, "dummy remote" ..... CSZZ-17696-CR  
 64-66 RH, Rotunda logo, "dummy remote", Concours Show-quality ..... CSZZ-17696-RR  
 67-68 RH, concours, "dummy remote" ..... C8AZ-17696-AR  
 67-68 RH, convex, "dummy remote" ..... C8AZ-17696-CR

**REMOTE MIRROR BEZEL**



A nice reproduction of the inner door Remote Mirror Bezel.

- Remote Mirror Bezel**  
 69 ..... C8SZ-17B733-B

**SPORT MIRROR BEZEL NUT**



A nice reproduction.

- Sport Mirror Bezel Nut**  
 69 ..... C6GY-17B719-A  
 70-71 ..... C9TZ-17B732-A

**MOLDING**

**EXTERIOR MOLDINGS**

**BODY MOLDING KIT**

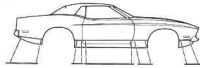

Featured on all deluxe decor group. Ten piece kit. Hardware not included.

- Body Molding Kit**  
 71-73 10 piece kit ..... D1ZZ-6320938KIT

**DRIP RAIL MOLDING**



Stainless steel stamped moldings that attach to drip rail or roof rail. Economy moldings to replace damaged or missing originals.

- Drip Rail Molding**  
 64-68 Coupe ..... CSZZ-6551726/7A  
 65-66 Fastback ..... CSZZ-6351726/7A  
 67-68 Fastback ..... C7ZZ-6351726/7A  
 69-70 Fastback, Steel drip channel that s/molding snaps onto ..... C9ZZ-6351726/7  
 69-70 Fastback ..... C9ZZ-6351726/7A  
 69-70 Coupe, without vinyl top ..... C9ZZ-6551726/7A

**DRIP RAIL MOLDING JOINT COVER**



Pressure die cast like original and chrome plated. Fastback only.

- Drip Rail Molding Joint Cover**  
 69-70 ..... C9ZZ-6351828/9A

**QUARTER WINDOW MOLDING**



Pressure die cast like original and chrome plated.

- Quarter Window Molding**  
 69-70 Fastback - U.S.A. Made ..... C9ZZ-6329796/7A  
 69-70 Fastback - Import ..... C9ZZ-6329796/7I

**QUARTER WINDOW TRIM**



Pressure die cast like original and chrome plated.

- Quarter Window Trim**  
 69-70 Coupe ..... C9ZZ-6529796/7

**FASTBACK DRIP RAIL SASH**



This is the decorative molding that the roof rail weatherstrip channel attaches to on Fastbacks.

- Drip Rail Sash, Fastback**  
 67-68 Fastback ..... C7ZZ-63517A10/1

**FASTBACK DOOR GLASS MOLDING**



Beautiful reproduction. Made from the original Ford Tooling. Made from rust proof 304 stainless steel. Attaches to back of door glass. Rubber seal sold separately.

- Fastback Door Glass Molding**  
 69-70 Fastback, Right hand .. DOZZ-6322220-A  
 69-70 Fastback, Left hand ..... DOZZ-6322221-A

**FENDER EXTENSION MOLDING**



- Fender Extension Molding**  
 70 RH ..... DOZZ-16074  
 70 LH ..... DOZZ-16075

**FRONT FENDER EXTENSION MOLDING**



Features die-cast zinc construction.

**Front Fender Extension Molding**

- 71-72 Chrome ..... D1ZZ-16160/1
- 71-72 Paint to match ..... D1ZZ-16160-B
- 73 Paint to match ..... D3ZZ-16160/1

**GRILLE MOLDING AND TRIM**



'64-'66 Fits on outside of grill opening. 64-70 molding includes mounting hardware. For all 71-73 molding, mounting clips are

sold separately.

**Grille Molding And Trim**

- 64-66 Right hand, wide ..... C5ZZ-8242-AR
- 64-66 Left hand, wide ..... C5ZZ-8243-AR
- 67-68 Right hand, wide ..... C7ZZ-8190-AR
- 67-68 Left hand, wide ..... C7ZZ-8191-AR
- 67-68 Right hand, narrow ..... C7ZZ-8242-AR
- 67-68 Left hand, narrow ..... C7ZZ-8243-AR
- 69 Lower grille panel ..... C9ZZ-8221-A
- 69 Right hand, wide ..... C9ZZ-8242-AR
- 69 Left hand, wide ..... C9ZZ-8243-AR
- 69 Right hand, narrow ..... C9ZZ-8242-BR
- 69 Left hand, narrow ..... C9ZZ-8243-BR
- 69 Center, narrow ..... C9ZZ-8419-AR
- 70 Center, wide, Lower ..... D0ZZ-16C694
- 71-72 Upper or lower ..... D1ZZ-8419-B
- 71-72 Right hand ..... D1ZZ-8419-C
- 71-72 Left hand ..... D1ZZ-8419-E
- 73 Right hand ..... D3ZZ-8242-A
- 73 Left hand ..... D3ZZ-8243-A
- 73 Upper or lower ..... D3ZZ-8419-C

**GRILLE MOLDING CENTER JOINT COVER**



Chrome is better than original, recessed area is painted Argent Silver. All necessary fasteners are included.

**Grille Molding Center Joint Cover**

- 66 Center ..... C6ZZ-8221-A
- 67-68 Center Joint Cover ..... C7ZZ-8221-AR

**HOOD MOLDING**

For the front of the hood, to trim the edge. 1964-70 versions are formed from aluminum, as the originals were.



Mounting hardware is included.

**Hood Molding**

- 64-66 Original Tooling ..... C5ZZ-16856
- 64-66 reproduction ..... C5ZZ-16856-A
- 67-68 ..... C7ZZ-16856-A
- 69 ..... C9ZZ-16856-A
- 70 ..... D0ZZ-16856-AR
- 71-72 Chrome ..... D1ZZ-16856-A
- 71-73 Ready to paint ..... D1ZZ-16856-B

**HOOD MOLDING SUPPORT**

Hood molding attaches to this commonly damaged or missing part.







**Hood Molding Support**

- 70 ..... D0ZZ-16C694

**MOLDING RETAINER CLIP**

Exact OEM replacements. Plated to stop corrosion.



**Molding Retainer Clip**

-  65  
C5ZZ-65423A26-A
-  66-73  
C5ZZ-65423A26-B
-  67-68: Coupe top rear molding only  
C7ZZ-65423A26-A
-  69-70: Lower  
C9ZZ-6503406-A

**QUARTER PANEL ORNAMENT**

Fine reproductions to ensure you of the finest quality, fit, and appearance.

**Quarter Panel Ornament**

-  64-65: Concours  
C5ZZ-65290A76/7
-  66: Concours  
C6ZZ-65290A76/7
-  66: Satin  
C6ZZ-65290A76/7S

**Quarter Panel Ornament**

-  67: Set of 4  
C7ZZ-65291A52/3
-  68: Chrome trim  
C8ZZ-65290A767A
-  68: Base, paint to match  
C8ZZ-65290C82/3
-  69  
C9ZZ-65290D14/5

**REAR WINDOW MOLDING KIT**

This is just the kit to replace that dented, scratched or missing rear window trim on your Mustang.



**Rear Window Molding Kit**

- 64-66 Coupe, 6 piece kit ..... C5ZZ-6542404
- 65-66 Fastback, 4 piece kit ..... C5ZZ-6342404
- 67-68 Fastback, 6 piece kit ..... C7ZZ-6342404
- 67-68 Coupe, 4 piece kit ..... C7ZZ-6542404
- 69-70 Fastback, 4 piece kit ..... C9ZZ-6342404
- 71-73 Fastback ..... D1ZZ-6342404

**ROCKER MOLDING**

Aluminum stampings, highly polished with a great fit. 64-69 moldings come with attaching hardware.

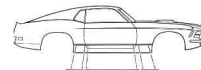

**Rocker Molding**

- 64-66 ..... C5ZZ-6510176/7A
- 67-68 ..... C7ZZ-6510176/7
- 69 ..... C9ZZ-6510176/7
- 70 Mach 1, concours ..... D0ZZ-6320938KIT
- 71-73 10 piece kit ..... D1ZZ-6320938KIT
- 71-73 ..... D1ZZ-6510176/7

**ROCKER MOLDING HARDWARE**

We offer these complete hardware kits for your customer's convenience. Kits include high strength backing plates and all



necessary screws, clips, or rivets.

**Molding Hardware**

- 64-66 Left or right ..... C5ZZ-6510182-K
- 67-68 Left hand ..... C7ZZ-6510182-KL

**WE PROUDLY FEATURE AUTHENTIC MUSTANG REPRODUCTIONS FROM SCOTT DRAKE ENTERPRISES!**



### Molding Hardware

67-68 Right hand ..... C7ZZ-6510182-KR

### TAIL LIGHT PANEL MOLDING

Polished aluminum moldings which fit on the honey comb optional panel. Please see sheetmetal section for honeycomb

panel. Will fit on all body styles for 1970 but is original for Mach 1 only.

#### Tail Light Panel Molding

71-73 2 piece kit ..... D1ZZ-63423A82/4

### TRUNK MOLDING

Brightly polished aluminum moldings that are easy to install. All moldings come with attaching hardware.

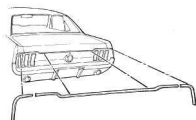

#### Trunk Molding

67-68 Fastback, right hand quarter extension trim ..... C7ZZ-6329078-A

67-68 Fastback, left hand quarter extension trim ..... C7ZZ-6329079-A

67-68 Fastback, trunk trim .... C7ZZ-6342512-A

67-68 Coupe/convertible, right hand quarter extension trim ..... C7ZZ-6529078-A

67-68 Coupe/convertible, left hand quarter extension trim ..... C7ZZ-6529079-A

67-68 Coupe/convertible, trunk trim ..... C7ZZ-6542512-A

69-70 Coupe/convertible, right hand quarter extension trim ..... C9ZZ-6529078-A

69-70 Coupe/convertible, left hand quarter extension trim ..... C9ZZ-6529079-A

69-70 Coupe/convertible, trunk trim ..... C9ZZ-6542512-A

### VINYL TOP MOLDING

Pressure die cast construction and chrome plated.



#### Vinyl Top Molding

65-66 ..... CSZZ-65423A18/9

67-68 ..... C7ZZ-65423A18/9

### WHEEL OPENING MOLDING

Our wheel opening moldings are roll-formed aluminum, just like the originals. Mounting screws are included with these



moldings.

#### Wheel Opening Molding

67-68 Front, right hand ..... C7ZZ-16038-B

### Wheel Opening Molding

67-68 Front, left hand ..... C7ZZ-16039-B

67-68 Rear, right hand ..... C7ZZ-6529164-A

67-68 Rear, left hand ..... C7ZZ-6529165-A

69 Front, right hand ..... C9ZZ-16038-B

69 Front, left hand ..... C9ZZ-16039-B

69 Fastback, rear, right hand ..... C9ZZ-6329164-A

69 Fastback, rear, left hand ..... C9ZZ-6329165-A

69 Coupe/convertible, rear, right hand ..... C9ZZ-6529164-A

69 Coupe/convertible, rear, left hand ..... C9ZZ-6529165-A

70 Front, right hand ..... D0ZZ-16038-B

70 Front, left hand ..... D0ZZ-16039-B

70 Fastback, rear, right hand ..... D0ZZ-6329164-A

70 Fastback, rear, left hand ..... D0ZZ-6329165-A

70 Coupe/convertible, rear, right hand ..... D0ZZ-6529164-A

70 Coupe/convertible, rear, left hand ..... D0ZZ-6529165-A

71-73 Front, right hand ..... D1ZZ-16038-AR

71-73 Front, left hand ..... D1ZZ-16039-AR

71-73 Rear, right hand ..... D1ZZ-6529164-AR

71-73 Rear, left hand ..... D1ZZ-6529165-AR

### WHEEL OPENING MOLDING KIT



Although not an original option, this kit is very popular. Our wheel opening moldings are roll-formed aluminum,

just like the 67-73 versions. Mounting screws included. All 4 moldings included in kit.

#### Wheel Opening Molding Kit

64-66 ..... CSZZ-16038-KIT

### WINDSHIELD MOLDING

These formed stainless steel moldings are a good reproduction at an economical price. They are polished like the originals.



#### Windshield Molding

64-68 CP/FB, 5 piece kit ..... CSZZ-6503136/48

64-68 Side, right hand ..... CSZZ-6503136-BR

64-68 Side, left hand ..... CSZZ-6503137-BR

64-68 Top, right hand ..... CSZZ-6503144-BR

64-68 Top, left hand ..... CSZZ-6503145-BR

64-68 Lower ..... CSZZ-6503148-BR

69-70 Fastback, 5 piece kit .. C9ZZ-630313448K

69-70 Coupe, 5 piece kit ..... C9ZZ-650313648K

71-73 Coupe, 2 piece ..... D1ZZ-650313648K

### CONVERTIBLE WINDSHIELD PILLAR MOLDING



Stainless steel, outer windshield pillar moldings for convertibles. Includes right and left hand side. Daily driver

quality to replace missing or damaged originals.

#### Windshield Pillar Molding, Convertible

64-68 ..... CSZZ-7603136/7B

### INTERIOR MOLDINGS

#### FRONT HEADLINER MOLDING

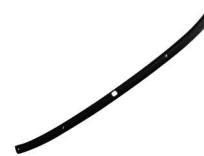

This trim molding is used where the headliner meets the front windshield. Fits both Coupes and Fastbacks. Painted

Black.

#### Headliner Molding, Front

69-70 ..... C9ZZ-6503606

#### WINDSHIELD FILLER PANEL

These moldings fill the gap between the windshield and the padded dash.



#### Windshield filler panel

67-68 2 piece filler molding C7ZZ-6504522/3A

## PAINT, TOOLS & RESTORATION SUPPLIES

### ADHESIVES & CLEANERS

#### HEADLINER GLUE



This high strength glue comes in an easy to use 4 ounce container with brush applicator built into lid.

#### Headliner Glue

64-73 ..... HLG-1829

**INSIDE REARVIEW MIRROR  
ADHESIVE**



Remounts rearview mirror bracket to windshield permanently. Mounting strength is 300 psi. Unaffected by

hot and cold temperature variation. Supplied in 0.04 ounce tube.

**Inside Rearview Mirror Adhesive**

64-73 .....PRO-61067

**ACCUMATCH INTERIOR PREP**



AccuMatch Interior Prep: A self-leveling, high-tech adhesion promoter, specifically formulated to fill nicks and scratches.

**Interior Prep, AccuMatch™**

64-73 ..... PP-2322

**ACCUMATCH SURFACE CLEANER**



AccuMatch Surface Cleaner - for properly preparing vinyl and plastic surfaces before application of prep or dye products.

**Surface Cleaner, AccuMatch™**

64-73 ..... LP-383

**SUPER TRIM ADHESIVE SPRAY**



Very fast acting contact adhesive designed for two surface applications. Great for vinyl tops, headliners, insulation

and padding. Supplied in a 19 ounce aerosol can. From 3M.

**Trim Adhesive Spray, Super**

64-73 ..... 3M-8090

**RAGGTOP VINYL CLEANER**



This is the best cleaner we have found. It is the only cleaner that has been tested and endorsed by HAARTZ and the Ford Motor

Company. HAARTZ is the world's largest manufacturer of convertible tops. Safely removes the toughest stains. Over spray will not harm painted finishes. Retards grease, dirt and mildew. Anti-oxidant formula with low PH and no bleach. Leaves no residue. Biodegradable. Must use before applying RT-VP protectant. 16 oz. spray bottle.

**Vinyl Cleaner, RAGGTOP**

64-73 ..... RT-VC

**RAGGTOP VINYL PROTECTANT**



This is the only protectant tested and endorsed by HAARTZ, the world's largest manufacturer of convertible tops.

The protective film repels stains, acid rain, tree sap, bird droppings, salt, tar, grease and mildew. Contains Cibi Tinuvin 5151, the best ultra violet blocker available. Improves water and stain repellency. Will not streak. Does not contain silicone. 16 oz. spray bottle.

**Vinyl Protectant, RAGGTOP**

64-73 ..... RT-VP

**WEATHERSTRIP ADHESIVE**

Supplied in five ounce tubes. From 3M.



**Weatherstrip Adhesive**

64-73 Yellow, not for EPDM rubber ... 3M-8001

64-73 Black, not for EPDM rubber ..... 3M-8008

64-73 Black, for EPDM rubber ..... 3M-8011

**PAINT & DYE**

**ACCUMATCH INTERIOR DYE**



This proprietary formula is approved by and meets Ford OEM performance specifications. It penetrates and

chemically bonds to any clean surface. Will not crack, flake or peel. This does it all: Vinyl, Carpets, leather, hard plastic, exterior trim, convertible tops and metal. Really anything associated with a vehicle. Actually penetrates and chemically bonds, will not crack, flake or peel. Quick Drying formula, so parts can be touched and installed in as quick as 10 minutes. Will not fill in grain pattern. Truly an OEM finish in an aerosol can. Yes a little more money but well worth it. When painting the outside of your car, do you typically buy the cheapest paint you can find" LP-383 and PP-2322 are recommended for professional results.

**Interior Dye, AccuMatch™**

64-65 Light palomino ..... V-17690

64-65 Medium blue, metallic ..... V-5747

64-65 Bright red ..... V-6022

64-66 Light ivy gold, metallic ..... V-5760

**Interior Dye, AccuMatch™**

64-66 White ..... V-5767

64-66 Black ..... V-946

64-73 Clear coat, finisher ..... V-CC

65 light blue, metallic ..... V-5748

65 Medium palomino, metallic ..... V-5759

66 Light turquoise, metallic ..... V-5752

66 Medium emberglow, metallic .... V-5777

66 Parchment, metallic ..... V-5779

66-67 Dark red, metallic ..... V-5773

67 Dark gold, metallic ..... V-5734

67-68 Light parchment ..... V-4595

67-68 Dark saddle ..... V-5738

67-68 Saddle ..... V-5739

67-68 Dark aqua, metallic ..... V-5753

67-68 Dark blue, metallic ..... V-5770

67-68 Light ivy gold, metallic ..... V-5778

67-73 Black/charcoal, metallic-iridescent ..... V-4464

68 Dark red, semi-gloss ..... V-5732

68 Dark red, flat ..... V-5792

68 Dark nugget gold, metallic ..... V-5798

68-69 Medium ivy gold, metallic ..... V-5756

68-69 Light nugget gold, metallic ..... V-5800

69 Dark red, metallic ..... V-15641

69 Dark ivy, metallic ..... V-15644

69 Dark red ..... V-15847

69 Dark ivy ..... V-15854

69-73 White ..... V-15855

70 Medium ivy green, metallic ..... V-15942

70 Vermillion ..... V-15945

70-73 Medium ginger ..... V-15939

70-73 Dark ginger ..... V-15940

70-93 Light graphite ..... V-117

70-93 Medium graphite ..... V-118

71-73 Medium blue, metallic ..... V-16049

71-73 Medium vermillion, metallic .... V-16050

73 Medium avacado ..... V-17023

**ACCUMATCH INTERIOR PAINT**



The AccuMatch(TM) Interior Paints are the result of years of work and perfectly match the original color shades. Each color has

been expertly color-matched. Paints feature extra-high pigment content for superior coverage, and patented fan-pattern nozzle for professional results.

**Interior Paint, AccuMatch™**

64-65 Light palomino ..... L-17690

64-65 Medium palomino, metallic ..... L-5759

64-65 Bright red, semi gloss ..... L-6022

64-66 Medium ivy gold, metallic ..... L-5756

Paint

**WE PROUDLY FEATURE AUTHENTIC MUSTANG  
REPRODUCTIONS FROM SCOTT DRAKE ENTERPRISES!**



**Interior Paint, AccuMatch™**

64-66	Light ivy gold, metallic	L-5760
64-66	White, semi gloss	L-5767
64-66	Black, semi gloss	L-946
64-70	Medium blue, metallic	L-5747
65-66	Light aqua, metallic	L-5752
65-69	Light blue, metallic	L-5748
66	Medium emberglow, metallic	L-5777
66	Parchment, semi gloss	L-5779
66-67	Dark red, metallic	L-5773
67	Dark gold, metallic	L-5734
67-68	Light parchment	L-4595
67-68	Dark saddle	L-5738
67-68	Saddle, semi gloss	L-5739
67-68	Dark aqua, metallic	L-5753
67-68	Dark blue, metallic	L-5770
67-68	Light ivy gold, metallic	L-5778
67-73	Black charcoal	L-4464
68	Dark red, metallic	L-5732
68	Dark red	L-5792
68	Dark nugget gold, metallic	L-5798
68-69	Light nugget gold, metallic	L-5800
69	Dark red, metallic	L-15641
69	Dark ivy, metallic	L-15644
69	Dark red	L-15847
69	Dark ivy	L-15854
69-73	White, semi gloss	L-15855
70	Ivy green, metallic	L-15942
70	Vermillion	L-15945
70-73	Ginger, semi gloss	L-15939
70-73	Dark ginger	L-15940
71-73	Medium blue, metallic	L-16049
71-73	Medium vermilion, metallic	L-16050
73	Medium avocado	L-17023

**ACCUMATCH DETAIL PAINT**

Our detail paints give a natural looking finish to metal surfaces.

**Paint, AccuMatch Detail**

64-73	Steel gray	RP-100
64-73	Cast iron gray	RP-101
64-73	Cast aluminum	RP-104

**ACCUMATCH DETAIL BLACK PAINT**

AccuMatch Detail Black is formulated with a correct 15% semi-gloss finish to match original OEM shades, and it's extra-high pigment content provides superior coverage over similar paints. Ideal for pulleys, brackets, aprons and most other underhood/chassis components. Provides extra protection against rust and corrosion to help prolong the

life of your vehicle's valuable components.

**Paint, AccuMatch Detail Black**

64-73	OEM detail black	RP-103
-------	------------------	--------

**ACCUMATCH ENGINE PAINT**

AccuMatch Engine Paints are a complete line of popular colors and formulas created specifically for engine compartment

applications. Engine paints come with higher heat tolerances to resist cracking and flaking, and are chemical resistant to resist corrosion from common engine compartment fluids such as gasoline. Formulated to color-match original OEM shades. Withstands temperatures up to 350° F.

**Paint, AccuMatch Engine**

64-65	Gold- similar to original gold color	EP-1005-A
65	6 cylinder, red	EP-1001-A
65	V8, black	EP-1724-A
66-73	Dark blue	EP-1923-A
70-73	Light blue	EP-0046-A

**ACCUMATCH HI-TEMP PAINT**

The Hi-Temp Gray paint from AccuMatch Products, is formulated specifically to withstand high engine compartment

temperatures up to 1200° F. Leaves pieces with a natural cast-iron finish with less applications due to its extra-high pigment content. Formulated to withstand extreme temperatures up to 1200°F Perfect for headers & exhaust manifolds.

**Paint, AccuMatch Hi-Temp**

64-73	Gray	RP-102
-------	------	--------

**ACCUMATCH MACH 1 MOLDING PAINT**

AccuMatch Dark Argent, Specialty Application Spray Paint (12 oz can). 1970 Mach 1 Molding" Specifically made for the 1970

Mach 1 grill and rocker panels.

**Paint, AccuMatch Mach 1 Molding**

70	Mach 1 molding, dark argent	L-17500
----	-----------------------------	---------

**ACCUMATCH MUSTANG GRILLE PAINT**

AccuMatch Gun Metal Blue, Specialty Application Spray Paint (12 oz can). 1964-65 Mustang Grill OEM" Gives an OEM accurate,

concourse-correct, gun-metal finish.

**Paint, AccuMatch Mustang Grille**

64-65		L-17530
-------	--	---------

**ACCUMATCH POWER STEERING PUMP PAINT**

AccuMatch Blue, Specialty Application Spray Paint (12 oz can). 1965-69 Power Steering Pump" Color formulated to match

original OEM Power Steering Pump color.

**Paint, AccuMatch Power Steering Pump**

65-69		L-17520
-------	--	---------

**ACCUMATCH WHEEL PAINT**

AccuMatch Wheel Paints are specifically formulated to correctly match the most popular wheel colors, including Charcoal

Gray and a Classic Argent Gray." Gives a smooth color-correct finish to wheel surfaces " Provides protection against corrosion and wear" Available in popular restoration colors.

**Paint, AccuMatch Wheel**

64-73	Classic argent gray	L-17510
65-67	Styled steel charcoal gray	L-17540

**EXTERIOR TOUCH UP PAINT**

These convenient 12 ounce aerosol cans are perfect for minor touch ups on the daily driver. Great for lower valances, door

jamb, underhood, inside trunk area and misc. spot repair. These are made from the original paint supplier to Ford in the sixties using the exact same lacquer formulas that Ford used. The 3rd digit in our part number is Ford's paint code that you will find on your door data tag. Please note that due to the fact that most cars have been repainted and there are many types of paint (synthetic enamel, acrylic enamel, lacquers, clear coats, etc.) plus deterioration and fading of older paint we can not guarantee a match. Note: Paint is not returnable.

**Paint, Exterior Touch Up**

64	Guardsman blue	PC-F-GB
64	Skylight blue	PC-Y-SK
64-65	Poppy red	PC-3-PR
64-65	Twilight turquoise	PC-5-TT
64-65	Phoenician yellow	PC-7-PY
64-65	Silver smoke gray	PC-K-SS
64-65	Prairie bronze	PC-P-PB
64-66	Ivy green	PC-R-IG
64-67	Springtime yellow	PC-8-SY
64-67	Vintage burgandy	PC-X-VB

**Paint, Exterior Touch Up**

64-71 Raven black	.....PC-A-BR
64-73 Wimbeldon white	.....PC-M-WW
65 Champaign beige	.....PC-I-CB
66 Signalfare red	.....PC-5-SR
66 Silver blue	.....PC-Y-SB
66-67 Silver frost	.....PC-4-SF
66-67 Arcadian blue	.....PC-F-AB
66-67 Nightmist blue	.....PC-K-NB
66-67 Sauterne gold	.....PC-Z-SG
66-68 Tahoe turquoise	.....PC-U-TT
66-70 Candyapple red	.....PC-T-CR
67 Dark moss green	.....PC-Y-DG
67-68 Pebble beige	.....PC-6-PB
67-68 Lime gold	.....PC-I-LG
67-68 Diamond blue	.....PC-N-DB
67-68 Brittany blue	.....PC-Q-BB
67-69 Acapulco blue	.....PC-D-AB
68 Presidential blue	.....PC-X-PB
68-69 Royal maroon	.....PC-B-RM
68-69 Gulfstream aqua	.....PC-F-GA
70-72 Grabber blue	.....PC-J-GB
71-73 Bright red	.....PC-3-BR

**MARKAL PAINT STICK**



Special paint sticks which were used by FORD at the assembly plants to mark fender aprons, radiator support, transmission,

rear end housing, sheet metal, glass and many other parts. These sticks are the attention to detail that wins shows.

**Paint Stick, Markal**

64-73 2 sticks, white and yellow	.....MPS-2
64-73 12 pack	.....MPS-KIT

**ACCUMATCH " SELF ETCHING PRIMER**



AccuMatch Self Etching Primers. Acrylic resin formula gives excellent adhesion to aluminum, bare metal, and other prepared

surfaces.

**Primer, AccuMatch " Self Etching**

64-73 Gray	.....RP-200
64-73 Red oxide	.....RP-201
64-73 Black	.....RP-202
64-73 Gray - weld through	.....RP-203

**ACCUMATCH FILLER PRIMER**



AccuMatch Filler Primer, Gray (18 oz)" Highest solid content for filling surface blemishes" Quick drying primer provides

extra hard sandable surfaces" Creates superior

base for maximum top-coat adhesion.

**Primer, AccuMatch Filler**

64-73	.....RP-204
-------	-------------

**ACCUMATCH PRO GRADE PRIMER**



AccuMatch Pro-Grade Primers (12 oz)" Creates superior base for maximum top-coat adhesion" Seals surface for excellent

durability.

**Primer, AccuMatch Pro Grade**

64-73 Gray	.....RP-206
------------	-------------

**ACCUMATCH ZINC PHOSPHATE PRIMER**



AccuMatch Zinc Phosphate Primer, Gray (12 oz)" Chemically bonds to aluminum and other metals " Two component

polyurethane epoxy provides exceptional protection against rust and moisture.

**Primer, AccuMatch Zinc Phosphate**

64-73 yellow/green	.....RP-205
--------------------	-------------

**ACCUMATCH UNDERCOATING**



AccuMatch automotive undercoatings are designed for complete undercarriage protection and sound-

deadening. Available in either a standard asphalt-based formula, and also in our new rubberized formula for extra protection and sound-deadening properties. Undercoatings come in extra large 15oz cans for even the biggest jobs.

**Undercoating, AccuMatch"**

64-73 Black, rubberized	.....RP-300
64-73 Black, asphalt	.....RP-301

**SEALANTS**

**BEDDING AND GLAZING COMPOUND**



This non-hardening, water resistant formula is designed for sealing windshields and rear windows on all cars using rubber

gaskets. This bedding compound can be used between glass and metal, or between glass and rubber. Locks out dust and air, remains flexible and resilient, can be used for installing

water shields. Supplied in 11 ounce tubes.

**Bedding And Glazing Compound**

64-73	.....3M-8509
-------	--------------

**BODY SEAM SEALER STRIPS**



Used to seal openings in the car body. Non-hardening, waterproof and will not shrink. Ideal for seams, cracks and joints. Especially

useful when hanging fenders and mounting fuel tanks for proper sealing. Supplied in five 13 foot sections for a total of 65 ft. Correct dark gray for early Mustangs.

**Body Seam Sealer Strips**

64-73	.....ESB-M4G32-A
-------	------------------

**HIGH TEMPERATURE SILICONE**



This red RTV silicone bonds to rubber, aluminum, steel and iron. Ideal for use on timing covers, oil pans, thermostat housings

and valve covers. This special formula is not affected by oils, grease, transmission fluid, antifreeze or temperatures up to 500 degrees. Form your own gasket, replaces paper, felt, rubber and cork gaskets. Supplied in 2.8 oz. tubes with nozzle.

**High Temperature Silicone**

64-73	.....CRL-55 RED
-------	-----------------

**STRIP BODY CAULKING**



Used to seal openings in the car body. Non-hardening, waterproof and will not shrink. Ideal for seams, cracks and joints. Especially

useful when hanging fenders and mounting fuel tanks for proper sealing. Supplied in a box of 60 one-foot lengths. Black only.

**Strip Body Caulking**

64-73	.....3M-8578
-------	--------------

**WINDSHIELD AND BODY SEALANT**



This non-hardening, water resistant formula is designed for sealing windshields and rear windows on all cars using rubber

gaskets. This bedding compound can be used between glass and metal, or between glass and rubber. Locks out dust and air, remains flexible and resilient, can be used for installing water shields. Supplied in 11 ounce tubes.

**Windshield And Body Sealant**

64-73 Non-hardening	.....CRL-7708
---------------------	---------------

Paint

**WE PROUDLY FEATURE AUTHENTIC MUSTANG REPRODUCTIONS FROM SCOTT DRAKE ENTERPRISES!**





### **WINDSHIELD SEALANT**



This formula cures into a tough, flexible, rubbery bead. Excellent adhesion to glass and all metals. Can be water tested

in minutes. Works well for sealing drip rails in addition to glue in windshields.

**Windshield Sealant**  
64-73 ..... CRL-7711

## **TOOLS**

### **BEZEL INSTALLATION TOOL**



This tool is perfect for installing or removing the chrome bezel on our 1967 Convertible Top Switch or the Antenna bezel on 2010

Mustangs.  
**Bezel Installation Tool**  
67 ..... 1967 CV Top Switch Bezel & 2010  
Antenna Bezel ..... T-67

### **DOOR HANDLE CLIP REMOVER**



Removes special retaining clip on early door handles and window cranks. Stamped steel construction.

**Door Handle Clip Remover**  
64-65 ..... T-87600

### **DOOR HINGE SPRING COMPRESSOR**



This finger saver, makes installing the spring on the lower hinge quick and easy. For use only on a bench (off-car) rebuild

and ALWAYS wear eye protection!  
**Door Hinge Spring Compressor**  
64-67 ..... T-87675

### **DOOR PANEL REMOVER**



Stamped steel construction. Allows removal of door panels with out causing damage to panel or fasteners.

**Door Panel Remover**  
64-73 ..... T-87650

### **EXTERNAL WIPER BEZEL NUT TOOL**



Specially designed for removing or installing bezel nuts, without risk of scratching or damaging bezel or paint.

**External Wiper Bezel Nut Tool**  
64-65 ..... T-120-BL

### **FOG LIGHT SWITCH BEZEL TOOL**



Another specialized tool used to install or remove the chrome bezel on the fog lamp switch. Helps prevent scratches from using

improper tools.  
**Fog Light Switch Bezel Tool**  
65-67 ..... T-65

### **IGNITION BEZEL TOOL**



Don't scratch that new bezel with a screw driver. A dedicated tool made by Scott Drake.

**Ignition Bezel Tool**  
67-68 ..... T-100-YL  
69 ..... T-109-CL

### **MOLDING REMOVER**



Great for windshield and rear window moldings. Stamped steel with red coated handle.

**Molding Remover**  
64-73 ..... T-87800

### **TOP VENT RIVET TOOL**



Finally the perfect tool for that tough little job. Includes 1 pair top seals and 4 rivets.

**Top Vent Rivet Tool**  
64-66 ..... T-225

### **GLASS RUN TOP VENT SEAT TOOL**



Time saving tool which removes old top vent window seals and installs new semi-tubular rivets with original looking results.

**Top Vent Seat Tool, Glass Run**  
64-66 ..... T-221

### **WIPER BEZEL STEM NUT TOOL**



Special tool designed to insert into wiper bezel stem nut used for assembly or disassembly. Will not damage nut.

**Wiper Bezel Stem Nut Tool**  
64-66 ..... T-110-RD

## **RUBBER PARTS & WEATHER STRIPPING**

### **EXTERIOR PADS AND SEALS**

#### **ANTENNA BASE GROMMET**



High quality compression molded neoprene rubber. Fits round base antennas.

**Antenna Base Grommet**  
64-67 ..... CSZZ-18A813-A

#### **BACK UP LIGHT LENS GASKET**

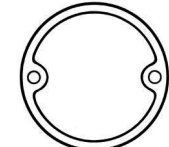

Molded sponge, good fit. Seals lens to housing.

**Back Up Light Lens Gasket**  
65-70 ..... CSZZ-15510-A

#### **BACK UP LIGHT PAD**



Molded Black rubber, good fit. Seals housing to rear valance panel.

**Back Up Light Pad**  
64-66 ..... CSZZ-15533-A/B  
67-70 ..... C7ZZ-15533-A

#### **BASIC REPAINT KIT**



This kit features some of the basics parts that are replaced during a basic repaint. Includes hood bumpers, door bumpers, trunk bumpers, tail lamp and lens gaskets, door handle pads, backup lamp pads, parking lamp pads, cowl to hood seal, antenna pad, trunk

housing pad and quarter cap seals.

**Basic Repaint Kit**

- 64-66 .....KIT-RUB-3
- 67-68 .....KIT-RUB-67-BODY

**DOOR AND QUARTER SEAL SCREW**

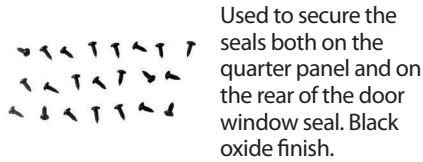

Used to secure the seals both on the quarter panel and on the rear of the door window seal. Black oxide finish.

**Door And Quarter Seal Screw**

- 64-73 Bulk, sold in bags of 100 .....52718-SMK
- 65-68 Set of 22 .....52718-S

**FRONT DOOR TO WINDOW SEAL**

Made from a high quality rubber. These feature a steel insert molded inside. Fits on rear door edge. See Hardware category for screws.

**Door To Window Seal, Front**



- 64-66  
C9Z-6520588/9B



- 67: Early 67 Cougar  
C7Z-6520588/9A



- 67-68: Late 67 Cougar  
C7Z-6520588/9B



- 69-70  
C9Z-6520264/5A

**FENDER EXTENSION SEAL**

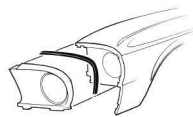

Small rubber extrusion which fits between headlight assembly and front fender edge. This cures chipping paint problems.

**Fender Extension Seal**

- 67-68 .....C7Z-13044
- 69-70 .....C9Z-13044

**FENDER SPLASH SHIELD KIT**

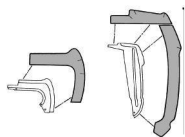

Scott Drake splash shield kits include the rubber seals and mounting hardware, for use with the customer's original splash shield plates or our new standard

splash shield plates or our new standard

splash shield plates.

**Fender Splash Shield Kit**

- 64-66 .....C5Z-16A572-A
- 67-68 .....C7Z-16A572-A

**FENDER TO BODY PILLAR PAD**



These pads fit near the cowl to prevent rattling or movement of the fenders against the body. Square, two required per car.

**Fender To Body Pillar Pad**

- 65-66 .....C5Z-16246

**HOOD SCOOP SEAL**

Fits behind hood scoop grill.

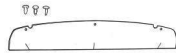

**Hood Scoop Seal**

- 67-70 .....C9Z-16666

**HOOD TURN SIGNAL LIGHT GASKET**

Hood Turn Signal Lamp Gaskets. Sold in Pairs.



**Hood Turn Signal Light Gasket**

- 67-68 .....C7Z-13A368

**LICENSE PLATE BUMPER**

These little bumpers remove big rattles. Fits front or rear valances. 1964-68 front and 1964-70 rear.



**License Plate Bumper**

- 64-70 .....375838-S1

**LICENSE PLATE LIGHT LENS GASKET**

Precision die-cut gaskets from the original material used on the Mustang.

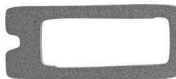

**License Plate Light Lens Gasket**

- 65-73 .....C7AZ-13568-A

**MARKER LIGHT LENS GASKET**

These parts are precision die-cut for a great fit the first time.



**Marker Light Lens Gasket**

- 68 Front .....C8Z-15A209
- 69 Set of 4 .....C9AZ-15A447
- 70 Rear .....D0ZZ-15A209
- 71-73 Front .....D1ZZ-15209

**OUTSIDE DOOR HANDLE PAD**



Fit between door handle and door body panel. Injection-molded plastic just like the original. Sold in complete sets only. 4

piece sets.

**Outside Door Handle Pad**

- 64-70 Does not fit 67-68 ....CODZ-6422428/9K
- 67-68 .....C7Z-6522428/9K

**QUARTER PANEL DRAIN PLUG**

Durable E.P.D.M. rubber for the most weathered part of the car, the inside rear quarter panels. 1967 - 1968 features a steel insert, like the originals.

**Quarter Panel Drain Plug**



- 64-66  
C40Z-62103A58-C



- 67-68  
C7Z-6511202-A

**QUARTER PANEL EXTENSION SEAL**



Installs between quarter panels and extensions to prevent paint from cracking. Added after early production models

showed problems in the split line between the two parts.

**Quarter Panel Extension Seal**

- 64-66 .....C5Z-6527802-C
- 67-68 .....C7Z-6527802-C
- 69-73 .....C9Z-6527802-C

**QUARTER PANEL GRILLE GASKET**

These gaskets are for the grille panels on the quarter panel. Sets of four each.



**Quarter Panel Grille Gasket**

- 67 .....C7Z-65291C80-C

Rubber

**WE PROUDLY FEATURE AUTHENTIC MUSTANG REPRODUCTIONS FROM SCOTT DRAKE ENTERPRISES!**



**QUARTER WINDOW TO BODY SEAL**

Made by Scott Drake, these Seals feature all the original details. Made of Quality rubber molded around a steel insert.

**Quarter Window To Body Seal**



64-66: Coupe and convertible  
C5Z-6528182/3

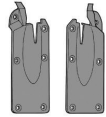

67-68: Coupe and convertible  
C7Z-6528182/3



69-70: Fastback  
C9Z-6328182/3A



69-70: Coupe and convertible  
C9Z-6528182/3B



71-73: Coupe and convertible  
D1Z-6528182/3B

**DOOR AND QUARTER SEAL SCREW**



Used to secure the seals both on the quarter panel and on the rear of the door window seal. Black oxide finish.

**Door And Quarter Seal Screw**

64-73 Bulk, sold in bags of 100 ..... 52718-SMK  
65-68 Set of 22 ..... 52718-S

**REAR LICENSE PLATE DUST SHIELD**



These rubber insulators prevent dust from accumulating on the surface of the license plate by stopping the airflow between the bumper and the rear valance.

**Rear License Plate Dust Shield**

67-68 ..... C7Z-6540427  
69-70 ..... C9Z-6540427

**SPOILER GASKET**



Our gaskets are made of high quality EPDM rubber to provide years of service. Not just a flat piece of rubber. These pads are formed to fit the slope of the trunk lid. Sold in

matching pairs.

**Spoiler Gasket**

69-73 ..... C9Z-6344228/9A

**TAIL LIGHT HOUSING GASKET**

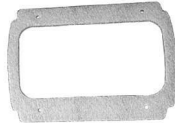

This gasket goes between the tail lamp housing and the body of the car on 1964 through 1966 Mustangs.

**Tail Light Housing Gasket**

64-66 ..... C5Z-13420-A  
67-68 Bezel to Lens ..... C7Z-13420-A  
69 ..... C9Z-13420-A

**TAIL LIGHT HOUSING TO BODY SEAL**



Thick black molded mounting pads which protect and seal trunk from water and dirt.

**Tail Light Housing To Body Seal**

67-68 ..... C7Z-13520  
69 ..... C9Z-13520  
70 ..... D0Z-13520  
71-73 ..... D1Z-13520

**TAIL LIGHT LENS GASKET**



Precision die-cut gaskets for hassle-free installation. Made from the original type of material in each case.

**Tail Light Lens Gasket**

64-66 ..... C5Z-13461-B  
67-68 ..... C7Z-13461-A  
67 Cougar and Shelby ..... C7WY-13461  
68-70 Shelby and Cal Special ..... C4SZ-13461-A  
69 ..... C9Z-13461-A

**TRUNK LID BUMPER**



Feature perfect shape, detail, and resilience in the material. Injection molded in E.P.D.M. rubber specifically for the Mustang, not a

universal type.

**Trunk Lid Bumper**

64-66 ..... C5Z-6543634  
67-70 ..... C7Z-6543634

**TRUNK LOCK CYLINDER HOUSING**

**PAD**

Precision molded pad to place behind the cylinder sleeve flange. Seals between the cylinder and trunk surface.

**Trunk Lock Cylinder Housing Pad**



64-66  
C5Z-6543625-B



67-73: Trunk and door locks  
C7AZ-6543625-A

**TRUNK SEAL**



Perfect reproductions of the original. Made from long lasting E.P.D.M. sponge rubber.

**Trunk Seal**

64-70 Coupe and convertible COMB-6443720-C  
65-66 Fastback ..... C5Z-6343720-B  
67-68 Fastback ..... C7Z-6343720-B  
69-70 Fastback ..... C9Z-6343720-A  
69-70 Shelby convertible ..... S9MS-7643720-A  
71-73 All body styles ..... D2WY-6543720-A

**VENT SEAL EDGE RIVET**



Correct black oxide semi-tubular rivet.

**Vent Seal Edge Rivet**

64-66 Set of 10 ..... 351603-S

**EXTERIOR WEATHER STRIP**

**FRONT DOOR GLASS RUN CHANNEL**



Vertical channel which runs behind vent window that door glass slides in. Features original type mohair inside channel, mounting bracket and stainless steel trim.

**Door Glass Run Channel, Front**

64-66 U.S.A. ..... C5Z-6521538/9A  
64-66 Import ..... C5Z-6521538/9I  
64-66 Import, right hand ..... C5Z-6521538-A  
64-66 Import, left hand ..... C5Z-6521539-A

**FRONT DOOR GLASS RUN INSERTS**

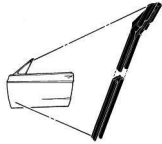

Insert to replace worn rubber and felt channel guide for door glass. Features original looking felt. Top molded pieces

are bonded securely and has steel inserts for added strength.

**Door Glass Run Inserts, Front**

67-68 ..... C7ZZ-6521546/7A

**VENT WINDOW CHANNEL**



Steel channel with door glass run insert installed.

**Vent Window Channel**

67-68 Right hand ..... C7ZZ-6521538-A

67-68 Left hand ..... C7ZZ-6521539-A

**VENT WINDOW DIVISION BAR SEAL**

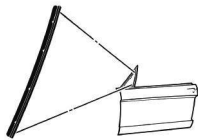

Offers a perfect fit with a steel insert molded into high quality E.P.D.M. rubber. Mounts on back side of vent window bar. Now

original type rivets included.

**Vent Window Division Bar Seal**

64-66 ..... CSZZ-6521450-A

**VENT WINDOW FRAME TO DOOR SEAL**

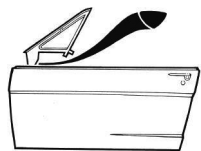

Seals between chrome vent frames and door on exterior side.

**Vent Window Frame To Door Seal**

67-68 ..... C60Z-6322280

**VENT WINDOW SEAL**



Our high quality Scott Drake reproduction vent seals offer your customers the finest molded rubber pieces available.

**Vent Window Seal**

64-66 Right hand and left hand .....

CSZZ-6521448/9B

64-66 Right hand ..... CSZZ-6521448-B

64-66 Left hand ..... CSZZ-6521449-B

67-68 Right hand ..... C7ZZ-6521448-AR

67-68 Left hand ..... C7ZZ-6521449-AR

**VENT WINDOW SEAL KIT**



Convenient time saving kit offers you everything to complete vent seal installation. Kit features vents seals, top vent

seals, back edge vent seals, and all rivets. Check out our rivet tools to make the job easier.

**Vent Window Seal Kit**

64-66 ..... KIT-RUB-5

**VENT WINDOW TO DOOR SEAL**

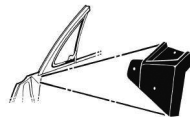

These high quality vent window seals are the first on the market to replace the original Ford part exactly. This is the small seal

at the front of the door and next to the door weatherstrip.

**Vent Window To Door Seal**

67-68 ..... C7ZZ-6522332/3

**QUARTER WINDOW SEAL**

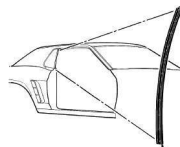

Made with long lasting E.P.D.M. rubber. Features the same detail as the originals. A steel insert is molded inside.

**Quarter Window Seal**

64-68 Coupe, right hand ..... CSZZ-6530146-B

64-68 Coupe, left hand ..... CSZZ-6530147-B

64-68 Convertible, right hand CSZZ-7630146-B

64-68 Convertible, left hand .. CSZZ-7630147-B

69 Coupe and convertible, right hand .....

C9ZZ-65214A14-A

69 Coupe and convertible, Left hand .....

C9ZZ-65214A15-A

71-73 Fastback, right hand ... D1ZZ-6330146-A

71-73 Fastback, left hand .... D1ZZ-6330147-A

71-73 Coupe and convertible, right hand .....

D1ZZ-6530146-A

71-73 Coupe and convertible, left hand .....

D1ZZ-6530147-A

**69-70 FASTBACK QUARTER WINDOW SEAL**



**Quarter Window Seal, 69-70 Fastback**

69-70 Fastback ..... C9ZZ-6330222-5

**DOOR GLASS TO QUARTER WINDOW SEAL**



Made with long lasting E.P.D.M. rubber. Features the same detail as the originals. A steel insert is molded inside.

**Quarter Window Seal, Door Glass To**

69-70 Fastback, right hand . D0ZZ-63214A14-R

69-70 Fastback, left hand ... D0ZZ-63214A15-R

**REAR VERTICAL GLASS RUN REPAIR KIT**



Original type style mohair/felt which covers run channel. Includes adhesive backing. Repairs both sides, Channel not

included. See "DOOR SECTION" for complete Runs.

**Rear Vertical Glass Run Repair Kit**

64-66 ..... CSZZ-6521508-RK

**REAR WINDOW SEAL**

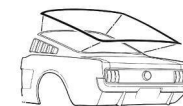

All of the below are made with superior quality E.P.D.M. rubber and feature transfer molded corners like the originals.

**Rear Window Seal**

64-68 Coupe ..... CSZZ-6542084-A

65-66 Fastback ..... CSZZ-6342084-A

67-68 Fastback ..... C7ZZ-6342084-A

69-70 Fastback ..... C9ZZ-6342084-A

69-70 Coupe ..... D0ZZ-6542084-A

71-73 Fastback ..... D1ZZ-6342084-A

71-73 Coupe ..... D1ZZ-6542084-A

**ROOF RAIL SEAL**



These are the best on the market. We welcome comparison. Made from a quality neoprene extrusion with transfer molded

ends, not glued ends like some competitors. Includes fastening pins.

**Roof Rail Seal**

64-66 Coupe ..... CSZZ-6551222/3C

65-66 Fastback ..... CSZZ-6351222/3C

67-68 Fastback ..... C7ZZ-6351222/3A

67-68 Coupe ..... C7ZZ-6551222/3C

69-70 Fastback ..... C9ZZ-6351222/3C

69-70 Coupe ..... C9ZZ-6551222/3A

71-73 Coupe ..... D1ZZ-6551222/3A

Rubber

**WE PROUDLY FEATURE AUTHENTIC MUSTANG REPRODUCTIONS FROM SCOTT DRAKE ENTERPRISES!**



**ROOF RAIL WEATHERSTRIP CLIP**



Metal clip to secure weatherstrip to roof rail.

**Roof Rail Weatherstrip Clip**

69-70 Coupe and Fastback ..... C9ZZ-6522204

71-73 For use at 1/4 window .... D1ZZ-6522204

71-73 For use at door ..... D1ZZ-6522244

**TOP VENT WINDOW SEAL**



Made from compression molded E.P.D.M. rubber with cadmium plated steel inserts molded inside. Includes rivets. Sold

in sets.

**Top Vent Window Seal**

64-66 ..... CSZZ-6521774/5A

**TRUNK WHEELHOUSE SEAM COVER**



Rubber strip to clean up the sharp edge of the wheel housing seam. Important for protecting luggage and other easily

damaged cargo. Fits left hand wheelhouse flange.

**Trunk Wheelhouse Seam Cover**

64-70 ..... CSZZ-6531466-A

**DOOR WEATHER STRIPPING**

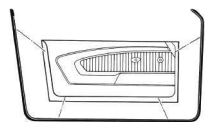

Made from the finest E.P.D.M. rubber, these sponge extrusions have transfer molded ends like the originals. These are not glued

and feature the correct cross section and size for proper sealing. Includes original looking mounting fasteners.

**Weather Stripping, Door**

64-66 Door ..... CSZZ-6520530/1A

67-68 Door ..... C7ZZ-6520530/1A

69-70 Door ..... C9ZZ-6520530/1A

71-73 Door ..... D1ZZ-6520530/1A

**DOOR BOTTOM WEATHER STRIPPING**

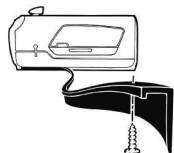

This seal cuts down wind and road noise. attaching hardware included.

**Weather Stripping, Door Bottom**

69-70 Door Bottom ..... C9ZZ-6520272-A

**WEATHERSTRIP FASTENER**



Made exactly like the originals. Black plastic. Used many places throughout the car including Vent Window to Door Seal.

**Weatherstrip Fastener**

64-68 Set of 4 ..... C1AB-6220807-A

**CONCOURS WINDOW CHANNEL STRIPS**



We proudly carry the full line of Re-Pops window channel strips. Rest assured that these are the highest quality on the market.

These window channel strips have the correct bends and staples. They also come with easy to understand instructions and a drill bit for installation. Made in the U.S.A.

**Window Channel Strips, Concours**

65-66 Fastback ..... CSZZ-6321458/9S

65-66 Coupe and convertible CSZZ-6521458/9S

67-68 Fastback ..... C7ZZ-6321458/9S

67-68 Coupe ..... C7ZZ-6521458/9S

67-68 Convertible ..... C7ZZ-7621458/9S

69-70 Fastback ..... C9ZZ-6321458/9S

69-70 Coupe ..... C9ZZ-6521458/9S

69-70 Convertible ..... C9ZZ-7621458/9S

71-73 Fastback ..... D1ZZ-6321458/9S

71-73 Coupe ..... D1ZZ-6521458/9S

71-73 Convertible ..... D1ZZ-7621458/9S

**ECONOMY WINDOW CHANNEL STRIPS**



These feature narrow outer strips rather than concours wide outer strips. Good alternative for daily drivers.

**Window Channel Strips, Economy**

64-66 Coupe and convertible, economy .....

CSZZ-6521458/9E

65-66 Fastback, economy .... CSZZ-6321458/9E

**QUALITY IMPORT WINDOW CHANNEL STRIPS**



These are a great alternative for those on a budget compared to our premium U.S.A. version. More like originals than our

economy versions, listed below.

**Window Channel Strips, Quality Import**

64-66 Coupe/Convertible .... CSZZ-6521458/9R

65-66 Fastback ..... CSZZ-6321458/9R

67-68 Fastback ..... C7ZZ-6321458/9R

**Window Channel Strips, Quality Import**

67-68 Coupe ..... C7ZZ-6521458/9R

**WINDOW SEALER**



Used to water-proof windshield and rear window. Silicone type sealer is best suited for glue in windshields.

**Window Sealer**

64-73 Non-hardening ..... CRL-7708

69-73 Silicone based ..... 3M-8606

**WINDSHIELD SEAL**



Made from superior quality E.P.D.M. rubber, excellent detail, features spliced transfer molded corners like originals.

These offer quality we stand behind. No others compare.

**Windshield Seal**

64-68 ..... CSZZ-6503110-A

**MOLDING RETAINER CLIP**



Exact OEM replacements. Plated to stop corrosion.

**Molding Retainer Clip**

64-65 Screw On ..... CSZZ-65423A26-A

66-73 ..... CSZZ-65423A26-B

67-68 Coupe top rear molding only .....

C7ZZ-65423A26-A

69-70 Lower Windshield ..... C9ZZ-6503406-A

**INTERIOR RUBBER**

**ACCELERATOR PEDAL**



These steel reinforced parts are molded from high quality rubber for a long life and great appearance.

**Accelerator Pedal**

64-68 With stainless trim ..... CSZZ-9735-D

69-70 Without trim ..... C9ZZ-9735-D

**ASH TRAY BUMPERS**

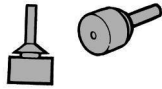

This is not a generic bumper. This one is built by Drake and is of the best quality and detail. An exact reproduction.

**Ash Tray Bumpers**  
64-66 .....380369-S

**AUTOMATIC TRANSMISSION SHIFT HOUSING PLUG**



Molded rubber plug, seals access hole in the side of shift housing.

**Automatic Transmission Shift Housing Plug**  
65-73 .....CSZZ-7C147-B

**BRAKE AND CLUTCH PEDAL PAD**



Sold as a matching set for the clutch and brake pedals for manual transmission cars. High quality EPDM rubber will look

great for years.  
**Brake and Clutch Pedal Pad**  
65-68 5 .....CSZZ-2457624-50

**BRAKE PEDAL PAD**

Made by Scott Drake with exact detail of the original. Compression molded rubber. Disc brake versions include stainless steel center trim.

**Brake Pedal Pad**



64-67: With power drum brakes  
CSZZ-2457-E



64-67: Drum brakes, automatic transmission  
CSZZ-2457-F



65-73: Drum brakes, manual transmission  
CSZZ-2457-G



68-73: Drum brakes, automatic  
C60Z-2457-A

**DISC BRAKE PEDAL PAD**

These reproduction pads are high quality replacements for worn or missing original pads.

**Brake Pedal Pad, Disc**



65-67: Disc brakes, automatic transmission  
CSZZ-2454-C



65-73: Disc brakes, manual transmission  
CSZZ-2454-D



68-73: Disc brakes, automatic transmission  
D3ZZ-2454-A

**BRAKE PEDAL PAD TRIM**

Replacement brake pedal pad trim.

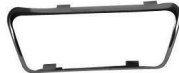

**Brake Pedal Pad Trim**

65-67 Automatic transmission .. CSZZ-2A487-B  
65-73 Manual transmission ..... D1ZZ-2A487-B  
68-73 Automatic transmission .. C60Z-2A487-A

**CLUTCH PEDAL PAD**

These reproduction pads are high quality replacements for worn or missing original pads.

**Clutch Pedal Pad**



65-68  
CSZZ-7A624-B



69-73  
C9ZZ-7A624-A

**CLUTCH PEDAL PAD TRIM**

Stainless steel.



**Clutch Pedal Pad Trim**

65-68 ..... CSZZ-7B544-A  
69-73 ..... C9ZZ-7B544-A

**DOOR LIGHT GASKET**

This pair of gaskets seal the door lamps to the door on Mustangs.



**Door Light Gasket**

65-66 .....CSZZ-13790  
67-68 ..... C90Z-13790-A

**FASTBACK SEAT BUMPERS**

These parts are pressure molded in high density E.P.D.M. rubber and are an exact fit.  
**Fastback Seat Bumpers**



65: Early 65  
372262-S



65-66: Set of 4  
372260-S



65-70: Late 65  
C6ZZ-6362426-A

**FASTBACK SEAT LATCH BUMPER**

This rubber bumper is used to keep the seat from rattling and also prevent damage when the seat is folded out for use.



**Fastback Seat Latch Bumper**

65-66 ..... CSZZ-63613B30  
67-70 ..... C7ZZ-63613B30/1

**FASTBACK TRAP DOOR BUMPERS**



**Fastback Trap Door Bumpers**

67-70 .....370374-S

**FIREWALL INSULATION FASTENERS**



**Firewall Insulation Fasteners**

64-73 Plastic replacement .....357036-S100-P  
68-73 Rubber ..... C8ZZ-6501691

Rubber

**WE PROUDLY FEATURE AUTHENTIC MUSTANG REPRODUCTIONS FROM SCOTT DRAKE ENTERPRISES!**



## GLOVE BOX DOOR BUMPERS



These are not off the shelf universal bumpers. These are the correct ones. Authentic in shape and detail.

### Glove Box Door Bumpers

64-66	.....	375838-S
67-70	.....	380239-S

## HEADLIGHT DIMMER SWITCH COVER PAD



Molded rubber cover which fits over headlamp dimmer switch.

### Headlight Dimmer Switch Cover Pad

65-73	.....	C5Z-13533
-------	-------	-----------

## INSTRUMENT LENS ANTI-RATTLE PAD



This kit takes away all the rattles caused from hardened and missing pads.

### Instrument Lens Anti-Rattle Pad

64-65	10 piece set	.....	C4DZ-10856
66	13 piece set	.....	C6DZ-10856

## PARKING BRAKE PEDAL PAD



Made by Scott Drake, this Parking Brake Pad is an exact copy of the original. Molded from wear resistant rubber for years of use.

### Parking Brake Pedal Pad

69-73	Note: Will not fit 1970 Mustang or Cougar	.....	C9Z-2454-A
-------	---	-------	------------

## PARKING BRAKE PEDAL PAD TRIM



Made from stainless steel, just like the originals.

### Parking Brake Pedal Pad Trim

69-73	Note: Will not fit 1970 Mustang or Cougar	.....	C9Z-2A487-C
-------	---	-------	-------------

## RUBBER GROMMET KIT



A time saving and complete grommet and rubber plug set. May or may not be exact fit for Cougar.

### Rubber Grommet Kit

64-66	30 piece	.....	C5Z-651135-K
67	29 piece	.....	C7Z-651135-K
68	39 piece	.....	C8Z-651135-K
69-70	44 piece	.....	C9Z-651135-K
71-73	13 piece	.....	D1Z-651135-K

## SEAT ACCESS HOLE PLUG



Molded rubber. Ours feature the right details including stamped engineering numbers on top.

### Seat Access Hole Plug

64-73	.....	377901-S
-------	-------	----------

## SHOCK ACCESS HOLE PLUG



Quality molded rubber. Features correct engineering numbers stamped on top.

### Shock Access Hole Plug

64-68	.....	378923-S
-------	-------	----------

## SUN VISOR TIP



Soft rubber tips to go over the ends of the sun visor rods.

### Sun Visor Tip

64-73	.....	D1DZ-6204115-A
-------	-------	----------------

## TENSION ROD ANTI-RATTLER

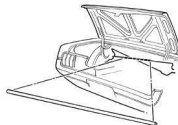

Designed to prevent vibration noise, these rubber sleeves slide over the trunk lid hinge tension rods.

### Tension Rod Anti-Rattler

64-68	.....	C5Z-6545028
-------	-------	-------------

## WASHER PUMP PEDAL PAD



Great reproduction of the original, with crisp detailing in the rubber.

### Washer Pump Pedal Pad

67-68	.....	C7Z-17664-P
-------	-------	-------------

## UNDERHOOD RUBBER

### ACCELERATOR ROD GROMMET



This piece seals the accelerator rod where it passes through the firewall. Stops cold air and wind noise from entering the interior

of the car.

### Accelerator Rod Grommet

64-66	.....	C4AZ-9793-A
67-68	.....	C60Z-9793-A

### COWL TO HOOD SEAL



Our cowl to hood seals have been engineered to fit right. Each one features perfect detail, cross sections match originals. Fasteners are

installed, or have pre-punched retainer holes when needed.

### Cowl To Hood Seal

64-66	.....	C5Z-16740-A
67-68	.....	C7Z-16740-A
69-70	.....	C9Z-16740
71-73	.....	D1Z-16740

### HOOD SEAL RETAINER CLIP

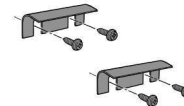

Stamped steel clips and mounting hardware included. Painted black. Kit includes 2 retaining clips and 4 mounting

screws.

### Hood Seal Retainer Clip

64-66	.....	C5Z-16A670-A
-------	-------	--------------

### FIREWALL TO HOOD BUMPERS



The Ford answer to anti-rattle on the hoods of the later Mustangs. Sold with attaching screws, and made to look exactly

like the originals.

### Firewall To Hood Bumpers

69-70	Pair	.....	380478-S2
71-73	Set of 3	.....	380478-S3

### FUEL LINE GROMMET



This is the grommet that protects the fuel line as it passes through the driver's side inner fender panel.

### Fuel Line Grommet

64-67	5/16"	.....	C5Z-9288
67-70	3/8"	.....	C7Z-9288
71-73	3/8", one-hole	.....	D1Z-9288

## GENERATOR SPLASH SHIELD

Die cut sheet rubber. Our reproduction splash shield is an exact duplicate of the original rubber boot.

### Generator Splash Shield

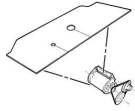

64: Outer  
C40Z-10170-C



64: Boot  
C40Z-10170-D

## BULK HOOD BUMPER

All of our hood bumpers feature detail which others don't have. Produced from high quality rubber.

### Hood Bumper, Bulk



64-68: Bulk  
C4DZ-16758-B



67-68: Bulk, rear  
C7WY-16758-B



69-70: Bulk  
C60Z-16758-A



71-73: Bulk  
D1ZZ-16758-A

## HOOD BUMPER KIT



All of our hood bumpers feature detail which others don't have. Produced from high quality rubber. Packaged in a

complete set of 4 bumpers.

### Hood Bumper Kit

64-66 Set of 4 ..... C5ZZ-16758-K  
67-68 Set of 4 ..... C7WY-16758-K  
69-70 Set of 4 ..... C60Z-16758-K  
71-73 Set of 4 ..... D1ZZ-16758-K

## DELUXE HOOD BUMPER KIT



All of our hood bumpers feature detail which others don't have. Produced from high quality rubber. Packaged in a

complete 6 piece set, for one car.

### Hood Bumper Kit, Deluxe

65-66 Deluxe, 6 piece kit .... C5ZZ-16758-DLXK  
67-68 Deluxe, 6 piece kit .... C7WY-16758-DLXK  
69-70 Deluxe, 6 piece kit .... C60Z-16758-DLXK  
71-73 Deluxe, 6 piece kit .... D1ZZ-16758-DLXK

## RADIATOR SUPPORT TO HOOD BUMPER

Durable E.P.D.M. rubber. Gold Cadmium plated shaft and nut.

### Radiator Support To Hood Bumper



64  
C5ZZ-16763-A



65-73  
C5ZZ-16763-B



65-73: Stainless Steel  
C5ZZ-16763-S

## RADIATOR SUPPORT TO HOOD SEAL



Quality E.P.D.M. rubber extrusion. This kit also includes staples. Fits all 6 cylinder and most big blocks.

### Radiator Support To Hood Seal

64-70 ..... C4DZ-16A238-A

## RAM AIR HOOD SEAL



The thick rubber seal that fits between the air cleaner and the hood scoop.

### Ram Air Hood Seal

71-73 Proper thickness ..... D1ZZ-9624

## UNDER HOOD SEAL KIT



Features cowl to hood seal, hood bumpers and radiator support to hood bumpers.

### Under Hood Seal Kit

64-66 ..... KIT-RUB-2

# SHEET METAL & BODY PARTS

## CHASSIS

### FRONT FLOOR EXTENSION



Made from 19 gauge steel. Extension for where the front floor and the firewall pedal area end up.

M126LH needs slight

trimming on 1969-1970 if using the original torque box. No trimming is required if using a reproduction torque box, M114A.

### Floor Extension, Front

64-68 Left hand ..... M126LH

64-68 Right hand ..... M126RH

### REAR FLOOR EXTENSION



Extension from rear floor to trunk. Specifically designed for coupes and Fastbacks, but will work for convertibles

with slight trimming.

### Floor Extension, Rear

64-68 Left hand ..... M131LH

64-68 Right hand ..... M131RH

### INNER FLOOR FRAME SUPPORT



Supports have sharp bends with good definition. 14 gauge adds strength.

### Floor Frame Support, Inner

64-68 Coupe and fastback, 4"W x 2 7/8"H x

29"L ..... M121

64-68 Convertible, 4"W x 2 7/8"H x 29"L ..... M121A

69-70 Coupe and Fastback ..... M121-69

71-73 Left hand ..... M221LH

71-73 Right hand ..... M221RH

### FULL LENGTH FLOOR PAN



Replace the whole side at once and save time. They are exact replacements for 1964-68. 1969-70 Mustangs have different ribbing

configurations. 1971-73 cars can use the 64-73 floor pans but requires modifications, therefore we recommend our new correct

**WE PROUDLY FEATURE AUTHENTIC MUSTANG REPRODUCTIONS FROM SCOTT DRAKE ENTERPRISES!**





71-73 pans.

**Floor Pan, Full Length**

- 64-73 Coupe and Fastback, 24"Wx60"L, Left hand .....M107-8ALH
- 64-73 Coupe and Fastback, 24"Wx60"L, Right hand ..... M107-8ARH
- 64-73 Convertible, 24"Wx60"L, Left hand ..... M107-8BLH
- 64-73 Convertible, 24"Wx60"L, Right hand ..... M107-8BRH
- 71-73 All, left hand, painted black ...M207-8LH
- 71-73 All, right hand, painted black M207-8RH

**COMPLETE FLOOR PAN KIT**



Original gauge sheet metal is used in the manufacturing of this beautiful part, not thinner gauge offered by some. Made to exact

specifications for a perfect fit. Finished in a smooth semi-gloss black paint. Includes lower reinforcement pans on convertible, floor pan plugs and seat access hole plugs. 69-70 floor's front ribbing differs from original.

- 64-68 Coupe and Fastback, includes seat platforms, M107-8-FFCP
- 64-68 Convertible, includes lower reinforcement pans, upper rear torque box patch, and rubber & metal plugs \*will fit 69-70 Conv w/ modification M107-8-FFCV
- 69-70 All body styles, includes seat platforms, upper rear torque box patch, and rubber & metal plugs \*will fit 69-70 Conv w/ modification M107-8-FFSTD

**Floor Pan Only**

- 64-68 Coupe and Fastback, Floor pan only CSZZ-6511135-FP
- 64-68 Convertible, Floor pan only CSZZ-7611135-FP
- 69-70 Coupe and Fastback, Floor pan only C9ZZ-6511135-FP

**LONG FRONT FLOOR PAN**



These floor pans will fit 1964 - 1973. They are exact replacements for 1964 - 1968. 1969 - 1970 cars have different ribbing

configurations. 1971 - 1973 cars can use but requires modifications.

**Floor Pan, Long Front**

- 64-73 Left hand, 23"Wx38 3/4"L ..... M107LH

**Floor Pan, Long Front**

- 64-73 Right hand, 23"Wx38 3/4L ..... M107RH

**REAR FLOOR PAN**



These floor pans will fit 1964 - 1973. They are exact replacements for 1964 - 1968.

1969 - 1970 cars have different ribbing

configurations. 1971 - 1973 cars can use but requires modifications.

**Floor Pan, Rear**

- 64-73 Left hand, 23 1/2"Wx21"L ..... M108LH
- 64-73 Right hand, 23 1/2"Wx21"L .... M108RH

**SHORT, FRONT FLOOR PAN**



These floor pans will fit 1964 - 1973. They are exact replacements for 1964 - 1968.

1969 - 1970 cars have different ribbing

configurations. 1971 - 1973 cars can use but requires modifications.

**Floor Pan, Short, Front**

- 64-73 Left hand, 24"Wx22 1/2"L ..... M106LH
- 64-73 Right hand, 24"Wx22 1/2"L .... M106RH

**FLOOR PAN SUPPORT**



Heavy duty floor support that connects inner floor frame supports. The transmission crossmember bolts to

this.

**Floor Pan Support**

- 64-66 ..... C5ZZ-6510692-B
- 67-68 ..... C7ZZ-6510692-B

**FRAME CROSSMEMBER**



Mount underneath oil pan connecting both frame rails together to reinforce front subframe assembly. Mounting bolts sold

separately under part # 379068-S.

**Frame Crossmember**

- 65-66 Front ..... C5ZZ-6510692-A
- 67-68 Front ..... C7ZZ-6510692-A

**FRAME CROSSMEMBER BOLTS**



**Frame Crossmember Bolts**

- 64-70 ..... 379068-S

**CONVERTIBLE INNER FRAME**

**PATCH**

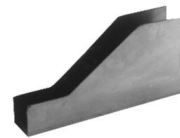

This improved part fits LH or RH. Made from high quality 14 gauge steel.

**Frame Patch, Convertible Inner**

- 64-70 Right hand or left hand, 14 gauge steel .. M122LR

**FRONT FRAME RAIL**

The best frame rail available. Gives the original appearance and strength when installed. Original style.

**Frame Rail, Front**



- 64-67: Left hand, outer only MC124LH



- 64-67: Right hand, outer only MC124RH



- 64-70: Left hand, 31" front patch, outer only MC124ALH



- 64-70: Right hand, 31" front patch, outer only MC124ARH



- 64-70: 2 piece, Left hand MC124FLH



- 64-70: 2 piece, Right hand MC124FRH



- 65-70: 1 piece, Right Hand C7ZZ-6510218-B



- 65-70: 1 piece, Left hand C7ZZ-6510219-B

### FULL REAR FRAME RAIL



We also offer a new version that is frame rail stamped as one complete piece like originals. Painted black. Torque Box

included, but not attached.

#### Frame Rail, Full Rear

65-68	Coupe and Fastback, Right hand,	
	conours .....	CSZZ-6510124NTB
65-68	Coupe and Fastback, Left hand, conours	
		CSZZ-6510125NTB
65-68	Convertible, RH, conours .....	
		CSZZ-7610125-KR
65-68	Convertible, LH, conours .....	
		CSZZ-7610125-KL

### REAR FRAME RAIL WITH TORQUE

#### BOX



Made in the U.S.A., these frame rails consists of a 3 sections welded together and reinforced with internal gussets at joints for extra strength, these also include torque box attached to save labor, and are shipped in raw steel.

#### Frame Rail with Torque Box, Rear

64-68	Convertible, right hand .....	
		MM102-A-103BRH
64-68	Convertible, left hand .....	
		MM102-A-103BLH
64-68	Coupe and Fastback, Right hand .....	
		MM102-A-103RH
64-68	Coupe and Fastback, Left hand .....	
		MM102-A-103LH
69-70	Convertible, right hand .....	
		MM302-A-103CR
69-70	Convertible, left hand ..	
		MM302-A-103CL
69-70	Coupe and fastback, right hand .....	
		MM302-A-103HR
69-70	Coupe and fastback, Left hand .....	
		MM302-A-103HL

### REAR FRAME RAIL PATCH



Gives the original appearance and strength when installed. Original style.

#### Frame Rail Patch, Rear

64-70	4"W x 5"H x 29-1/2"L, Left hand .....	
		M103ALH
64-70	4"W x 5"H x 29-1/2"L, Right hand .....	
		M103ARH

### OVER AXLE FRAME RAIL



Curved part of frame over the differential, right or left hand.

#### Frame Rail, Over Axle

64-69 24" long, right hand or left hand. MM102

### CONVERTIBLE REINFORCEMENT

#### PAN



Add structural strength to your convertible, seat holes are already drilled.

#### Reinforcement Pan, Convertible

64-68	Left hand, raw steel .....	M120LH
64-68	Right hand, raw steel .....	M120RH

### CONVERTIBLE REINFORCEMENT

#### PLATE



Bolts to lower pans for added strength.

#### Reinforcement Plate, Convertible

64-70 .....

### SEAT BELT ANCHOR PLATE



Now you can replace this original part, which is commonly striped out, with a nice reproduction. Must be welded to rear floor.

pan.

#### Seat Belt Anchor Plate

64-73 Weld in place .....

### SEAT PLATFORM



Replace and re-enforce the mounting area for the seat.

#### Seat Platform

64-68	Coupe and fastback, Left hand .	M132LH
64-68	Coupe and fastback, Right hand	M132RH
69-70	Fastback, Left hand .....	M232LH
69-70	Fastback, Right hand .....	M232RH

### CONVERTIBLE SEAT PLATFORM



To repair that rusty or damaged seat platform.

#### Seat Platform, Convertible

64-70 Convertible .....

### OUTER SHOCK TOWER



Stamped from 16 gauge steel with stronger 16 gauge one piece inner support welded in place.

#### Shock Tower, Outer

64-66	Left hand, Painted black .....	M125LH
64-66	Right hand, Painted black .....	M125RH
67-70	Left hand .....	M225LH
67-70	Right hand .....	M225RH

### SHOCK TOWER AND APRON ASSEMBLY



A beautiful repair panel, this includes a complete front frame rail, full front and rear inner front fender aprons and complete

inner and outer shock tower. This piece will replace it all. Must be shipped by truck only.

#### Shock Tower And Apron Assembly

64-66	Right hand .....	CSZZ-16054-RHC
64-66	Left hand .....	CSZZ-16055-LHC
67-68	Right hand .....	C7ZZ-16054-RHC
67-68	Left hand .....	C7ZZ-16055-LHC
69-70	Right hand .....	C9ZZ-16054-RHC
69-70	Left hand .....	C9ZZ-16055-LHC

### SHOCK TOWER CAP



These precision crafted, steel stamped reproductions are perfect replacements for broken, bent or ugly originals. Each

cap contains both front shock nuts pressed into place.

#### Shock Tower Cap

64-66	Black .....	CSZZ-18A017-A
64-66	Chrome .....	CSZZ-18A017-C
67-70	Black .....	C7ZZ-18A017-A
67-70	Chrome .....	C7ZZ-18A017-C

**WE PROUDLY FEATURE AUTHENTIC MUSTANG REPRODUCTIONS FROM SCOTT DRAKE ENTERPRISES!**



### INNER SHOCK TOWER PATCH

To replace the damaged or rusted lower shock tower.

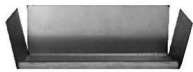

Shock Tower Patch, Inner  
64-66 ..... M129

### SHOCK TOWER WITH BRACKET



A welcomed reproduction part to replace those damaged towers. Painted black.

Shock Tower With Bracket  
65-66 Right hand ..... CSZZ-6503438-C  
64-66 Left hand ..... CSZZ-6503439-C  
67-68 Right hand ..... C7ZZ-6503438-C  
67-68 Left hand ..... C7ZZ-6503439-C  
69-70 Right hand ..... C9ZZ-6503438-C  
69-70 Left hand ..... C9ZZ-6503439-C

### STRUT ROD BRACKET

High quality steel, painted black.



Strut Rod Bracket  
64-66 Left hand ..... CSZZ-6503487-L  
64-66 Right hand ..... CSZZ-6503487-R  
67-70 Left hand, lower ..... C7ZZ-6503487-L  
67-70 Right hand, lower ..... C7ZZ-6503487-R

### TORQUE BOX

To allow for complete clutch adjustment the left side has full original impression. High quality 14 gauge steel. \*Note: M114ALH



must be modified for 69-70.  
Torque Box  
64-68 Convertible, left hand ..... M114LH  
64-68 Convertible, right hand ..... M114RH  
67-70 Coupe/Fastback, left hand\* ..... M114ALH  
69-70 Coupe/Fastback, left hand ..... M114BLH  
67-70 Coupe/Fastback, right hand ... M114ARH

### UPPER REAR TORQUE BOX

To replace or patch the upper torque box.



Torque Box, Upper Rear  
64-68 Left hand ..... M130LH

### Torque Box, Upper Rear

64-68 Right hand ..... M130RH

### REAR TORQUE BOX PATCH

Complete for frame rail over the rear axle. Welded into one piece like original.



### Torque Box Patch, Rear

64-70 Convertible, left hand ..... MM102CLH  
64-70 Convertible, right hand ..... MM102CRH  
64-70 Coupe, left hand ..... MM102LH  
64-70 Coupe, right hand ..... MM102RH

### TRANSITION PAN

Original gauge sheet metal is used in the manufacturing of this beautiful part. Made to exact specifications for a perfect fit. Finished



in a smooth semi-gloss black paint. Shock mounts are included.

### Transition Pan

64-68 With shock mounts ..... M3649

### TRANSMISSION CROSSMEMBER



### Transmission Support

65-66 All ..... CSZZ-7A383-A  
67-70 200, 289, 302 ..... C7ZZ-6A203-A  
67-68 Big block C6 ..... C7ZZ-7A383-B

## FENDERS, DOORS AND FRONT VALANCE

### CUSTOM FIBERGLASS BODY KIT



Give you mustang a classic look! Not only do these cars look great, they are the hottest

thing out there right now. The manufacturer went to great lengths to make sure this high quality kit was as easy to install as possible. We recommend that this kit be installed by an experienced fiberglass installer. Kit includes 18 parts. Hood, Nose, Headlamp buckets, wheel flares, side skirts, side scoops, tail panel, quarter extensions and deck lid. Also available,

E2 Body Kits for 1965-66 Mustangs!  
Custom Fiberglass Body Kit  
67-68 ..... S7MS-E-FGMK

### CUSTOM FRONT SUPPORT BRACKET

This new restoration part from Scott Drake will help in building your very own Eleanor. The support brace bolts to



factory bumper bracket holes. It serves two purposes by acting as a reinforcement for the lower nose, and as well as providing the mounting location for Eleanor Driving Lights. It is finished in a black textured powder coated surface. Get yours today to help make your dream car a reality.

### Custom Front Support Bracket

67-68 ..... S7MS-FSB

### COMPLETE DOOR SHELL

Brand new tooling. Good fit offers a good alternative to a used door.



### Door Shell, Complete

64-66 Right hand ..... CSZZ-6520124-B  
64-66 Left hand ..... CSZZ-6520125-B  
67-68 Right hand ..... C7ZZ-6520124-B  
67-68 Left hand ..... C7ZZ-6520125-B  
69-70 Right hand ..... D0ZZ-6520124-A  
69-70 Left hand ..... D0ZZ-6520125-A

### DOOR SKIN

A good quality reproduction Door Skin. Painted black. Ready to install.



### Door Skin

64-66 Right hand ..... CSZZ-6520200-A  
64-66 Left hand ..... CSZZ-6520201-A  
67-68 Right hand ..... C7ZZ-6520200-A  
67-68 Left hand ..... C7ZZ-6520201-A  
69-70 Right hand ..... C9ZZ-6520200-A  
69-70 Left hand ..... C9ZZ-6520201-A

### LOWER DOOR SKIN

Repairs lower section of door. Full length 47"L x 8"H.



### Door Skin, Lower

64-66 Left hand ..... M110LH

**Door Skin, Lower**

64-66 Right hand ..... M110RH

**LOWER REAR CORNER OF FENDER**

Comes with rear edge to form door opening.



**Fender, Lower Rear Corner Of**

64-66 Left hand ..... M104LH  
 64-66 Right hand ..... M104RH  
 67-68 Left hand ..... M204LH  
 67-68 Right hand ..... M204RH

**REPRODUCTION FENDER**



Our reproduction fenders offer an inexpensive alternative to purchasing O.E.M. parts, with only a slight loss in fit when

compared with genuine Ford parts. Shipped painted black and deburred.

**Fender, Reproduction**

64-66 Right hand ..... C5ZZ-16005-AR  
 64-66 Left hand ..... C5ZZ-16006-AR  
 67 Right hand ..... C7ZZ-16005-AR  
 67 Left hand ..... C7ZZ-16006-AR  
 68 Right hand ..... C8ZZ-16005-AR  
 68 Left hand ..... C8ZZ-16006-AR  
 69 Right hand ..... C9ZZ-16005-AR  
 69 Left hand ..... C9ZZ-16006-AR  
 70 Right hand ..... D0ZZ-16005-AR  
 70 Left hand ..... D0ZZ-16006-AR  
 71-72 Right hand ..... D1ZZ-16005-AR  
 71-72 Left hand ..... D1ZZ-16006-AR  
 73 Right hand ..... D3ZZ-16005-AR  
 73 Left hand ..... D3ZZ-16006-AR

**FENDER FROM FORD OEM TOOLING**



Scott Drake now offers superior quality replacement sheetmetal produced from Ford's original tooling and in most

cases by Ford's original manufacturer. These parts come with an electrostatically applied epoxy base primer for superior adhesion and rust protection. These are by far the best products on the market.

**Fender from Ford OEM Tooling**

65-66 Right hand ..... C5ZZ-16005-A  
 65-66 Left hand ..... C5ZZ-16006-A  
 67 Right hand ..... C7ZZ-16005-A  
 67 Left hand ..... C7ZZ-16006-A  
 68 Right hand ..... C8ZZ-16005-A  
 68 Left hand ..... C8ZZ-16006-A



**1965-66 MUSTANG E-2 BODY KITS**

The styling of the E2 Body Kit is a Mustang Depot exclusive now available through Scott Drake, evolutionary design inspired by the 1967 Eleanor body and working it around the 1965-66 model year cars. Available for Coupe/Convertible and Fastback models, this kit breaks away from the idea that these kits

only belong on a Fastback. For even more customization, each kit comes with your choice of 1 of 5 hood styles (be sure to note your hood choice when ordering).

**Complete the look with a Scott Drake Billet Grille, see the "Grille" section of our catalog.**

Kits include: hood (choose 1 of 5), headlight buckets, upper nose (1 piece), lower nose, front fender flares, side exhaust skirts, rear fender flares, lower side scoops, upper side scoops (fastback only), and a spoiler trunk w/end caps.

**\*\* Prices below are based on being Drop Shipped directly from manufacturer to you. All Kits subject to a \$50 Packaging fee and Nose Assembly a \$20 packaging fee by Manufacturer. Any parts that you wish to be brought into the Scott Drake warehouse and consolidated with you Scott Drake Order will have additional handling charges added: \$10 per part number for individual pieces or \$50 per Kit. \*\***



65-66 Kit: Coupe/Convertible FS-ELN-E2CP  
 65-66 Kit: Fastback FS-ELN-E2FB

65-66 Upper nose assembly (3 pc) includes headlight buckets FS-ELN2-UN3  
 65-66 Upper nose (1 pc) FS-ELN2-UN  
 65-66 Lower nose/apron FS-ELN2-LN  
 65-66 Hood: E2 Lowrise FS-ELN2-HDLR  
 65-66 Hood: B9 Style FS-ELN2-HDHR  
 65-66 Front Flare 1.25", Left hand FS-ELN2-FFL  
 65-66 Front Flare 1.25", Right hand FS-ELN2-FFR  
 65-66 Front Flare 1.75", Left hand FS-ELN2-RFL  
 65-66 Front Flare 1.75", Right hand FS-ELN2-RFR  
 65-66 Headlight bucket, Left hand FS-ELN2-HBL  
 65-66 Headlight bucket, Right hand FS-ELN2-HBR  
 65-66 Lower side scoop, Left hand FS-ELN2-LSL  
 65-66 Lower side scoop, Right hand FS-ELN2-LSR  
 65-66 Upper side scoop, Left hand FS-ELN2-USL  
 65-66 Upper side scoop, Right hand FS-ELN2-USR  
 65-66 Side exhaust skirts, Left hand (for use with E2 flares) FS-ELN2-SSL  
 65-66 Side exhaust skirts, Right hand (for use with E2 flares) FS-ELN2-SSR  
 65-66 Side exhaust skirts (for use without E2 flares) FS-M-7001SS  
 65-66 Ground effects kit (4 pc) for use without flares, includes 2 side skirts & 2 rear corners FS-M110  
 65-66 Spoiler trunk w/ end caps, Fastback FS-656TK1  
 65-66 Spoiler trunk w/ end caps, Coupe/Convertible FS-656TK2

65-66 S Style Tail Light Panel for use with 68-70 Shelby style lights FS-M227

**Additional accessories not in kit**



S-Style Tail Light Panel - available separately (#FS-M227)

**E2 Body Kit Hood Options**

Must choose hood style when ordering our E2 Kit above

**E2 Lowrise**

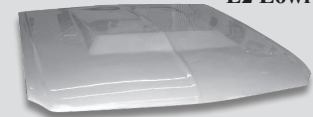

**500KR (\$50 upcharge)**



**3" Cowl**

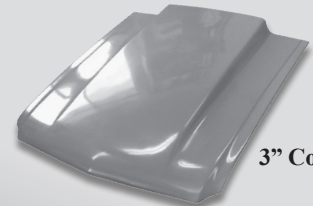

**S Scoop**

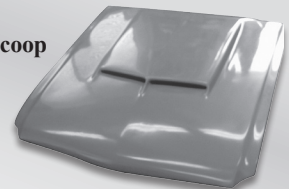

**G Style**

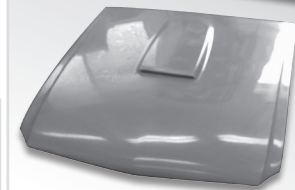

Sheet Metal

**WE PROUDLY FEATURE AUTHENTIC MUSTANG REPRODUCTIONS FROM SCOTT DRAKE ENTERPRISES!**



### FRONT FENDER MOLDING



Made from Original Ford Tooling for 1971-72 Mustangs! This part is paint to match. Also available in chrome.

#### Fender Molding, Front

71-72 Paint to match ..... D1ZZ-16160-B

### FENDER TO BUMPER FILLERS



For 71-72 Mustangs with chrome front bumper. This is molded soft plastic that fills the gap between the bumper and fender.

Exact reproduction and exact colors as the originals. Includes attaching screws.

#### Fender to Bumper Fillers

71-72 ..... D1ZZ-16554

### FRONT LICENSE BRACKET



Bracket used to mount a front license plate to the valance.

#### Front License Bracket

69-70 ..... C9ZZ-17A385-B

71-73 Chrome bumper ..... D1ZZ-17A385-A

71-73 Urethane bumper ..... D1ZZ-6540522-A

### FRONT SPOILER



Vacuumed formed impact resistant plastic with textured surface.

#### Front Spoiler

64-66 ..... CSZZ-63001A74-A

67-68 ..... C7ZZ-63001A74-A

69 ..... C9ZZ-63001A74-A

70 ..... D0ZZ-63001A74-A

71-73 ..... D1ZZ-63001A74-A

### FRONT VALANCE



Our stampings are all carefully tooled to eliminate fit-up problems during installation. We offer the best

fitting valances in the business for satisfied customers each time.

#### Front Valance

64-66 OEM Tooling ..... CSZZ-17A939-A

64-66 Economy ..... CSZZ-17A939-AR

64-66 New Improved Tooling ..... CSZZ-17A939-AC

67-68 OEM Tooling ..... C7ZZ-17A939-A

#### Front Valance

67-68 Economy ..... C7ZZ-17A939-AR

67-68 New Improved Tooling ..... C7ZZ-17A939-AC

69 ..... C9ZZ-17A939-AR

70 ..... D0ZZ-17A939-AR

71-72 ..... D1ZZ-17A939-AR

73 ..... D3ZZ-17A939-AR

### FIBERGLASS FRONT VALANCE



#### Front Valance, Fiberglass

64-66 R model, use with front bumper ..... SIMS-17A939-RB

67-68 R model, use with front bumper ..... S7MS-17A939-R

### GRILLE SUPPORT BRACKET



#### Grille Support Bracket

69 ..... C9ZZ-8182-A

70 ..... D0ZZ-8232-A

### LOWER GRILLE SUPPORT BRACKET



#### Lower Grille Support Bracket

64-66 Black Economy ..... CSZZ-8390-FR

64-66 Black Best Quality ..... CSZZ-8390-F

### HEADLIGHT BUCKET ASSEMBLY

Kits contain most mounting hardware. Reproduction unless otherwise noted. Headlight Bucket Assembly



65-66: Right hand

C5ZZ-13008-CR



65-66: Left hand

C5ZZ-13008-DR

### Headlight Bucket Assembly



67-68: Right hand

C7ZZ-13008-



67-68: Left hand

C7ZZ-13008-DR



69: Right hand

C9ZZ-16018-R



69: Left hand

C9ZZ-16019-L



70: Right hand

D0ZZ-16018-R



70: Left hand

D0ZZ-16019-L

### HEADLIGHT BUCKET HOUSING



#### Headlight Bucket Housing

65-66 Left hand ..... CSZZ-13100-L

65-66 Right hand ..... CSZZ-13100-R

67-68 NOS Right hand \* ..... C7ZZ-13008-C-HO

67-68 NOS, Left hand \* ..... C7ZZ-13008-D-HO

70 Right hand ..... D0ZZ-16018

70 Left hand ..... D0ZZ-16019

### HEADLIGHT DOOR

Die cast headlamp door which fits on the headlamp assembly. Primered.

#### Headlight Door



65-66: Left hand

C5ZZ-13064-A



65-66: Right hand

C5ZZ-13064-B

**Headlight Door**



67-68: Primered  
C7Z-13064-A



67-68: Chrome, both sides w/  
chrome screws  
C7Z-13064-C



69: Outer, chrome  
C9Z-13064-A



69: Inner  
C9Z-13064-B/C



70  
DOZZ

**HEADLIGHT EXTENSION PLATE**



**Headlight Extension Plate**

70 Right hand ..... DOZZ-16G556-A  
70 Left hand ..... DOZZ-16G557-A

**INNER STRUCTURE OF FENDER**

Inner structure behind the lower rear corner of the fender. Very common to rust.

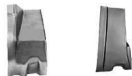

**Inner Structure Of Fender**

64-66 Left hand ..... M104ALH  
64-66 Right hand ..... M104ARH  
67-68 Left hand ..... M204ALH  
67-68 Right hand ..... M204ARH

**NOSE BRACKET**

Used on Shelby cars. Stamped steel construction, like original. Painted black.



**Nose Bracket**

68 Right hand, Shelby ..... S8MS-17792-A  
68 Left hand, Shelby ..... S8MS-17793-A

**NOSE REINFORCEMENT**

Used on Shelby cars. Stamped metal to give fiberglass extra support.



**Nose Reinforcement**

68 ..... S8MS-8B231-A

**PARKING LIGHT RETAINER**

Stamped steel and zinc plated to prevent rust. Fits behind parking lamps.



**Parking Light Retainer**

64-66 Right hand ..... CSZZ-13220-C  
64-66 Left hand ..... CSZZ-13221-C  
67-68 Right hand ..... C7Z-13220-A  
67-68 Left hand ..... C7Z-13221-A

**COMPLETE ROCKER PANELS**

Renew the structural strength of your Mustang. These Rocker Panels feature a new design now with thicker metal! The only ones using internal reinforcement braces like originals. Also feature rockers' original radius not sharp bends. Outer Rocker Panel only will be available early 2012.



64-66 Fastback/Coupe, Complete RH ..... CSZZ-6510128  
64-66 Fastback/Coupe, Complete LH ..... CSZZ-6510129  
67-68 Fastback/Coupe, Complete RH ..... CSZZ-6510128-A  
67-68 Fastback/Coupe, Complete LH ..... CSZZ-6510129-A



64-66 Convertible, Complete RH ..... CSZZ-7610128-C  
64-66 Convertible, Complete LH ..... CSZZ-7610129-C  
67-68 Convertible, Complete RH ..... C7Z-7610128-C  
67-68 Convertible, Complete LH ..... C7Z-7610129-C



64-68 Convertible, inner LH ..... M112LH  
6"W x 2 5/8"H x 75"L

64-68 Convertible, inner RH ..... M112RH  
6"W x 2 5/8"H x 75"L



69-73 Convertible, inner LH ..... M112ALH  
69-73 Convertible, inner RH ..... M112ARH



64-68 Lower front patch, LH ..... M141LH  
64-68 Lower front patch, RH ..... M141RH

**DELUXE SPLASH SHIELD**

All new stampings which include fresh rubber, securely attached. A real time saver.



**Splash Shield, Deluxe**

64-66 Front, right ..... CSZZ-16102-AR  
64-66 Rear, right ..... CSZZ-16102-BR  
64-66 Front, left ..... CSZZ-16103-AR  
64-66 Rear, left ..... CSZZ-16103-BR  
67-68 Front, right ..... C7Z-16102-AR  
67-68 Rear, right ..... C7Z-16102-BR  
67-68 Front, left ..... C7Z-16103-AR  
67-68 Rear, left ..... C7Z-16103-BR

**STANDARD SPLASH SHIELD**

New stampings which need to have our rubber splash shield kit attached prior to use. See the "Rubber & Weatherstripping"



category earlier in this catalog.

**Splash Shield, Standard**

64-66 Front, left ..... CSZZ-16103-A  
64-66 Rear, left ..... CSZZ-16103-B  
65-66 Front, right ..... CSZZ-16102-A  
65-66 Rear, right ..... CSZZ-16102-B  
67-68 Front, right ..... C7Z-16102-A  
67-68 Rear, right ..... C7Z-16102-B  
67-68 Front, left ..... C7Z-16103-A  
67-68 Rear, left ..... C7Z-16103-B

**REAR SPLASH SHIELD SUPPORT BRACKET**



Splash Shield Support Bracket, Rear  
67-68 ..... C7Z-16256/7-A

Sheet Metal

**WE PROUDLY FEATURE AUTHENTIC MUSTANG REPRODUCTIONS FROM SCOTT DRAKE ENTERPRISES!**



181

### STONE DEFLECTOR

Mounts behind the front bumper. Stamped steel, shipped lacquered black for protection.



#### Stone Deflector

- 64-66 From OEM tooling .....C5ZZ-17779-A
- 64-66 Economy, import .....C5ZZ-17779-AR
- 64-66 From new improved tooling Thicker metal .....C5ZZ-17779-B
- 67-68 From OEM tooling .....C7ZZ-17779-A
- 67-68 From new improved tooling .....C7ZZ-17779-AR
- 69 .....C9ZZ-17779-AR
- 70 .....D0ZZ-17779-AR

### STONE DEFLECTOR BRACKET

Three piece metal stone guard bracket set. Flat black coated like originals.



#### Stone Deflector Bracket

- 67-68 .....C7ZZ-17747-AR

### VALANCE TO FRAME BRACKET

Brackets to attach the front valance to the inner bumper brace.



#### Valance To Frame Bracket

- 69-70 .....C9ZZ-17747-A

## HOOD AND ENGINE COMPARTMENT

### BATTERY APRON PLATE

A repair panel to re-enforce the section that gets eaten away around the battery.



#### Battery Apron Plate

- 69 Right hand .....C9ZZ-16052-P

### COWL COVER

With Scott Drakes Classic Mustang Cowl Covers, you can eliminate water, dirt, and leaves from entering through



the cowl vent. The use of Poly Methyl Methacrylate plastic (PMMA) helps prevent rusty cowls and soggy carpet that can lead to rusty floors. New Drake low-profile design

easily installed or removed with only a coin.

#### Cowl Cover

- 64-66 ..... ACC-16741-65
- 67-68 ..... ACC-16741-67
- 69-70 ..... ACC-16741-69

### COWL GRILLE ASSEMBLY

Complete assembly for 64-68. 69-70 does not come with Upper Cowl Panel.



#### Cowl Grille Assembly

- 65-66 Assembly .....C5ZZ-6502010/28
- 67-68 Assembly .....C7ZZ-6502010/28
- 69-70 .....C9ZZ-6502010/28

### COWL PANEL



#### Cowl Panel, Lower

- 67-68 Lower .....C7ZZ-6502010-A
- 69-70 Middle .....C9ZZ-6502010-A

### UPPER COWL PANEL



#### Cowl Panel, Upper

- 67-68 .....C7ZZ-6502228-A
- 69-70 .....C9ZZ-6502228-A

### COWL SIDE PANEL

Fits under the cowl and behind the wheelwell. Patch panel pictured.



#### Cowl Side Panel

- 64-66 Right Hand .....C5ZZ-6502042-R
- 64-66 Left Hand .....C5ZZ-6502043-L
- 67-68 Right Hand .....C7ZZ-6502042-R
- 67-68 Left Hand.....C7ZZ-6502043-L
- 64-68 Left Hand, Patch Panel ..... M133LH
- 64-68 Right Hand, Patch Panel ..... M133RH
- 69-70 Right Hand Outer Panel..C9ZZ-6502044-R
- 69-70 Left Hand Outer Panel.....C9ZZ-6502044-L

### COWL VENT REPAIR KIT

For the frequently rusted cowl area. Kit includes sleeves, sealant, and instructions. Provides a watertight repair for



this trouble area.

#### Cowl Vent Repair Kit

- 64-68 .....C5ZZ-6502010-K

### COWL VENT REPAIR PANEL

This part commonly needs to be replaced on restoration projects due to rust damage over time.

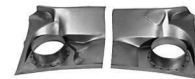

#### Cowl Vent Repair Panel

- 64-68 Left hand ..... M136LH
- 64-68 Right hand .....M136RH

### FRONT FENDER APRON

Good seller, many need replacing due to front end collisions, rust, & battery acid damage.



#### Fender Apron, Front

- 64-66 Left hand, Quality Import ..... M116LH
- 64-66 U.S.A., right hand ..... M116RH
- 67-68 Import, right hand .....C7ZZ-16054-A
- 67-68 Left hand Quality Import..C7ZZ-16055-A
- 67-68 Import, left hand Economy..... M216LH
- 67-68 U.S.A., right hand ..... M216RH
- 67-68 Economy Import, right hand ..M216RH-T
- 69-70 Import, right hand .....C9ZZ-16054-AR
- 69-70 Import, left hand .....C9ZZ-16055-AR
- 71-73 Import, left hand ..... M416LH
- 71-73 Import, right hand ..... M416RH

### REAR FENDER APRON

Hood hinges bolt to these aprons. Made from heavy gauge steel.



#### Fender Apron, Rear

- 64-66 Left hand ..... M127LH
- 64-66 Right hand ..... M127RH
- 67-68 Left hand ..... M227LH
- 67-68 Right hand .....M227RH
- 69-70 Left hand ..... M327LH
- 69-70 Right hand ..... M327RH
- 71-73 Left hand ..... M427LH
- 71-73 Right hand .....M427RH

### FENDER APRON BRACKET

Attaches to cowl and back of fender apron.



#### Fender Apron Bracket

- 64-66 Left hand .....M127ALH
- 64-66 Right hand .....M127ARH
- 67-68 Left hand .....M227ALH
- 67-68 Right hand .....M227ARH
- 69-70 Left hand .....M327ALH
- 69-70 Right hand .....M327ARH

### INNER FRONT FENDER BRACKET

Connects the fender to the front fender apron.



#### Fender Bracket, Inner Front

- 64-66 Left hand ..... M123LH
- 64-66 Right hand ..... M123RH

### FULL FIREWALL

A nice reproduction stamping, ready to weld in place. Painted satin black. Convertibles require trimming.



#### Firewall, Full

- 64-66 Fastback and coupe ..... M134
- 67-68 Fastback and coupe ..C7ZZ-6501605-FW
- 69-70 Fastback & Coupe .....C9ZZ-6501605-FW

### PARTIAL FIREWALL OUTER



#### Firewall Outer, Partial

- 64-68 Left hand ..... M134LH
- 64-68 Right hand ..... M134RH

### FRONT CROSS MEMBER

Stamped steel construction. Many get damaged due to improper jack lifting or front end collisions.



#### Front Cross Member

- 64-66 ..... MM133
- 67-70 Economy, w/out holes drilled & nut ..... MM233

#### Front Cross Member

- 67-70 w/ holes drilled & center nut ..... MM233-WH

### FIBERGLASS SHELBY HOOD

#### Hood, Fiberglass Shelby



- 65-66: With metal frame S1MS-16612-MF

### FORD OEM TOOLING HOOD

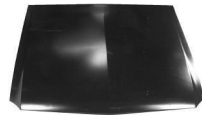

Superior quality replacement sheetmetal hood produced from Ford's original tooling and in most cases by Ford's original manufacturer. These parts come with an electrostatically applied epoxy base primer for superior adhesion and rust protection.

#### Hood, Ford OEM Tooling

- 64 With sharp edges .....C4ZZ-16612-B
- 65-66 .....C5ZZ-16612-B
- 67-68 Without turn signal reliefs C7ZZ-16612-C
- 67-68 With turn-signal reliefs ....C7ZZ-16612-D
- 69-70 Underside correct for 1970 ..... D0ZZ-16612-A

### REPRODUCTION HOOD



Our reproduction hoods are formed and assembled overseas for an inexpensive alternative to O.E.M. parts. Shipped

lacquered black for corrosion protection.

#### Hood, Reproduction

- 65-66 New tooling! Very good fit ..... CSZZ-16612-BR
- 67-68 Without turn signal reliefs ..... C7ZZ-16612-CR
- 67-68 With turn signal reliefs ..C7ZZ-16612-DR
- 69-70 Underside correct for 69 .C9ZZ-16612-AR
- 69-70 with Shaker hole cut .C9ZZ-16612-SHKR
- 70 with Twist Lock and Shaker holes cut .... D0ZZ-16612-M/SH
- 70 with Twist Lock holes cut D0ZZ-16612-TL
- 71-73 With 2 scoop cut outs ... D1ZZ-16612-AR

### HOOD HINGE

Heavy duty steel stampings. Painted black.



#### Hood Hinge

- 64-66 Right hand ..... C30Z-16796-AR

#### Hood Hinge

- 64-66 Left hand ..... C30Z-16797-AR
- 67-70 Right hand .....C7ZZ-16796-AR
- 67-70 Left hand .....C7ZZ-16797-AR

### HOOD HINGE MOUNTING KIT



#### Hood Hinge Mounting Kit

- 64-70 ..... 359662-SMK

### HOOD HINGE SPRING

Standard equipment springs for that finishing touch on the hinges. Not for Shelby cars with fiberglass hoods.



#### Hood Hinge Spring

- 64-70 Concours U.S.A. .... C30Z-16789-A
- 64-70 Imported ..... C30Z-16789-AR
- 65-68 for Shelby Fiberglass hood ..S7MS-16785

### HOOD LATCH

Complete latch now available. With or without top plate. Painted black.

#### Hood Latch



- 64-65: With top plate CSZZ-16700



- 65: With support brace CSZZ-16700-K



- 66: With support plate C6ZZ-16700



- 66: w/ out support plate C6ZZ-16700-B



- 67-68: Bolts on hood C7ZZ-16700-C



- 69-70 C9ZZ-16700-A

Sheet Metal

**WE PROUDLY FEATURE AUTHENTIC MUSTANG REPRODUCTIONS FROM SCOTT DRAKE ENTERPRISES!**



183

Authorized Dealer



### Hood Latch



71-73 Silver zinc plated. Quality reproduction.  
D1ZZ-16700

### HOOD LATCH PIN

Hood Latch Pin. Nut and Washer Included.



Hood Latch Pin  
64-66 .....C5ZZ-16929-A

### HOOD LATCH STRIKER

Made by Scott Drake this Stainless Steel Hood Latch Striker replaces the old, original steel striker. Made from polished



stainless steel for a great look and long life!  
Hood Latch Striker  
67-68 Stainless Steel .....C7ZZ-16929-S

### HOOD LATCH SUPPORT

A nice Reproduction of the Hood Latch Support. Painted black.



Hood Latch Support  
67-68 .....C7ZZ-16700-A  
69-70 .....C9ZZ-16700-R

### HOOD LATCH SUPPORT BRACE

This brace is used to reinforce the hood latch where it fastens to the core support on 1965 and 1966 Mustangs.



Hood Latch Support Brace  
64-66 .....C5ZZ-16747-A

### HOOD PROP ROD

This prop rod is made from high quality 304 stainless steel rod and polished to really catch the eye. Stainless steel washers and spring also included. Total rod length is 35 inches but can be cut to length if desired.



Hood Prop Rod  
64-68 Stainless .....C5ZZ-16826-S  
65 Shelby .....S1MS-16826

### HOOD SAFETY LATCH

Painted black.



Hood Safety Latch  
64-66 .....C4DZ-16918-B  
64-66 Stainless Steel .....C4DZ-16918-S

### HOOD SCOOP

#### Hood Scoop



65-66: Shelby, bond on  
S1MS-16025-A



67-68: Eleanor, bond on  
S7MS-16025-E



69-70: Mach/GT, Bolt on  
C9ZZ-16C630-A



71-73  
D1ZZ-16C630/1

### SHAKER HOOD TRIM RING

Pressure die cast construction. Hides raw edge of hood. Includes two mounting brackets.



*Brackets available under part # C9ZZ-16995-A. See Engine Section for shaker hoods.*  
Shaker Hood Trim Ring

69-70 .....C9ZZ-16958-A

### HOOD SCOOP GRILLE

Grille that fits across the front of the hood scoop to keep out birds and low flying aircraft.  
Hood Scoop Grille



69-70: Mach 1, Billet  
C9ZZ-16A624-BLT



69-70: Mach 1, Original  
C9ZZ-16A624-C

### Hood Scoop Grille



71-73  
D1ZZ-16A624/5-A

### HOOD TURN SIGNAL INSERT

Now made by Scott Drake. Quality die cast with exact fit and detail. We made the grill support straps stronger to prevent



breakage to this commonly broken area. Includes grill and studs. Ready to paint.

Hood Turn Signal Insert  
67-68 Right hand .....C7ZZ-16720-A  
67-68 Left hand .....C7ZZ-16721-A

### HOOD TURN SIGNAL INSERT GRILLE

Now made by Scott Drake. Exact detail. Ready to paint.



### Hood Turn Signal Insert Grille

67-68 .....C7ZZ-16870-A

### RADIATOR SUPPORT

Heavy gauge steel stampings for serious front sheet metal repairs. Shipped lacquered black for corrosion protection.



Available with or without lower crossmember attached.

#### Radiator Support

64-66 .....C5ZZ-16138-A

64-66 with crossmember attached .....C5ZZ-16138-WCM

67-68 .....C7ZZ-16138-B

69 .....C9ZZ-16138-A

70 .....D0ZZ-16138-A

71-73 .....D1ZZ-16138-A

67-68 with crossmember attached .....C7ZZ-16138-WCM

69 with crossmember attached .....C9ZZ-16138-WCM

70 with crossmember attached .....D0ZZ-16138-WCM

## INSULATION AND SOUND DEADENER

### FIREWALL INSULATOR



Features bonded thermal insulation. Mounting kit included. Die cut for a good fit or molded for a perfect fit.

#### Firewall Insulator

- 64-66 Die-cut, economy ..... C5ZZ-6501670-A
- 64-66 All Molded..... MUST-6466-C
- 67-68 Die-cut, economy ..... C7ZZ-6501670-A
- 67-68 w/o Factory AC Molded .. MUST-6768-HC
- 69-70 Die-cut, economy ..... C9ZZ-6501670-A
- 71-73 Die-cut, economy ..... D1ZZ-6501670-A

### ACCOUSTISHIELD FIREWALL INSULATOR



QuietRide Mustang Firewall Insulators are vacuum molded from a high definition rubber material to fit the exact contours of

the humps and heater wells of the Mustang cars. Firewall insulators are year make and model specific for heater only cars, Factory AC cars and Mach I cars. HeatShield insulation is added for increased thermal acoustic stop engine heat and noise from entering the passenger cabin. All factory holes are punched or perforated for easy installation. Conours quality. Mounting pins included.

#### Firewall Insulator, AcoustiShield

- 64-66 All ..... C5ZZ-6501670-M
- 67-68 w/Factory AC ..... MUST-6768-AC
- 67-68 w/o Factory AC ..... C7ZZ-6501670-M
- 69-70 All ..... MUST-6970-C
- 69-70 All Mach1 ..... MUST-6970-CMI

### ACCOUSTISHIELD PRE CUT KITS



These AcoustiShield Kits by QuietRide are Pre-Cut and adhesive backed and ready to install. They feature both Dynamat and

Heatshield layers to offer a superior barrier against Heat/Cold, Sound and Vibration. Makes your Classic much more enjoyable to drive. *Note: All parts listed below are drop-ship only.*

#### AcoustiShield Pre Cut Kits

- 64-68 Coupe Complete..... MUST-6468-CAK
- 64-68 Coupe Package Tray.....MUST-6468-CPK
- 64-68 Coupe Roof.....MUST-6468-CRK
- 64-68 Coupe Seat Divider.....MUST-6468-CSD
- 64-68 Fastback Body Part ... MUST-6468-FBBPK

### AccoustiShield Pre Cut Kits

- 64-68 Cowl .....MUST-6468-FCCCK
- 64-68 Coupe and fastback Floor Kit..... MUST-6468-FCCFK
- 67-68 Fastback, Body panel MUST-6768-FBBPK
- 67-68 Fastback, Roof .....MUST-6768-FBRK
- 69-70 Convertible Complete..MUST-6970-CVAK
- 69-70 Fastback Complete.....MUST-6970-FBAK
- 69-70 Floor .....MUST-6970-FCCFK

### HUSHMAT MEGABOND SILENCER INSULATION



Eliminate road noise, vibration and add thermal insulation with premium damping products from Hushmat. Hushmat

offers more than 18 years in automotive OEM experience! HushMat Megabond Silencer is the perfect material to use to reduce heat transfer from your big engine, drive train or exhaust and reduces the high frequency noise caused by road surface variation (tire noise), engine noise, and wind noise passing behind trim panels. Aggressive butyl based adhesive on back for one step peel and stick application. Stick to sheet metal or fiberglass vehicle surface or directly onto aluminum surface of HushMat Ultra vibration damping material for the ultimate COOL & QUIET interior.

#### HushMat Megabond Silencer Insulation

- 64-73 Door & headliner - 2 sheets 1/8" thick 23"x35" foam ..... HM-SIL-1003
- 64-73 Firewall & floor kit - 2 sheets of 1/4" thick 23"x35" foam ..... HM-SIL-1008

### HUSHMAT ULTRA INSULATION



Eliminate road noise, vibration and add thermal insulation with premium damping products from Hushmat. Hushmat

offers more than 18 years in automotive OEM experience! HushMatUltra features a 1/8" thick and 0.53 lb per square foot pressure-sensitive, constrained-layer damping material which has excellent adhesion for many difficult to-bond-to substrates such as oily steel, automotive E-coat, primers, finishes, laminated and chopper-gun fiberglass and many plastics, including polypropylene.

#### HushMat Ultra Insulation

- 64-73 Floor/dash kit - 20 sheets of silver 12"x23" ..... HM-4005

### UNDERHOOD INSULATION



Rarely seen, as most cars with this option had been removed years ago. Helps reduce engine noise.



#### Insulation, Underhood

- 69-70 ..... M274

### SOUND DEADENER KIT



All made with die cut precision that makes them easy to install. Drastically reduces road noise and helps insulate your car from

the heat and cold. Includes all pieces originally available for you particular year and bodystyle. Made from E.V.A. Our most complete kit. Kits include the following: L.H. and R.H. Front, Center Trans Hump, Rear Floor, Under Rear Seat, Transition and Trunk sections. 7 piece kit.

#### Sound Deadener Kit

- 64-68 Coupe ..... UL-CP
- 64-68 Convertible ..... UL-CV
- 65-68 Fastback ..... UL-FB
- 69-73 Coupe ..... UL-CP-L
- 69-73 Convertible ..... UL-CV-L
- 69-73 Fastback ..... UL-FB-L

### QUARTER PANEL, TOP AND REAR

### DRAIN HOLE COVER



Like original, The screws are included for these galvanized and die stamped drain hole covers.

#### Drain Hole Cover

- 64-73 ..... MM-111

### LOWER PANEL IN FRONT OF REAR WHEEL



Lower portion of wheel opening with bottom and front edge included.

#### Lower Panel In Front Of Rear Wheel

- 64-66 Left hand .....M102ALH
- 64-66 Right hand ..... M102ARH

Sheet Metal

**WE PROUDLY FEATURE AUTHENTIC MUSTANG REPRODUCTIONS FROM SCOTT DRAKE ENTERPRISES!**



185

### **PANEL BEHIND REAR WINDOW**



This commonly rusted part fits between the rear window and the trunk lid. Finished in semi-gloss epoxy primer.

#### **Panel Behind Rear Window**

64-66 Convertible .....	M128
64-66 Coupe .....	M128-CP
67-68 Coupe .....	M228-CP

### **LOWER REAR QUARTER PANEL**



Covers the lower rear section of the quarter panel. Has pressed-in seams on the bottom and has the contour of the wheel

opening. Also has an offset on the top edge for installation.

#### **Quarter Panel, Lower Rear**

64-66 Left hand .....	M100ALH
64-66 Right hand .....	M100ARH
67-68 Left hand .....	M200LH
67-68 Right hand .....	M200RH
69-70 Left hand, Fastback .....	M300ALH
69-70 Right hand, Fastback .....	M300ARH
69-70 Left hand, coupe/convertible ...	M300LH
69-70 Right hand, coupe/convertible .	M300RH
71-73 Left hand .....	M400LH
71-73 Right hand .....	M400RH

### **PARTIAL QUARTER PANEL**



Longer version of the rear wheel flares. Extends all the way to the door jamb and overlaps 1".

#### **Quarter Panel, Partial**

64-66 Left hand .....	M101ALH
64-66 Right hand .....	M101ARH
67-68 Left hand .....	M201ALH
67-68 Right hand .....	M201ARH
71-73 Left hand .....	M401LH
71-73 Right hand .....	M401RH

### **QUARTER PANEL ASSEMBLY**



These reproduction quarter panels offer an affordable replacement for this most complicated of body panels. Shipped

lacquered black for corrosion protection prior to installation.

#### **Quarter Panel Assembly**

64-66 Coupe, right hand .....	CSZZ-6527846-BR
64-66 Coupe, left hand .....	CSZZ-6527847-BR
64-66 Convertible, right hand .....	CSZZ-7627846-AR

#### **Quarter Panel Assembly**

64-66 Convertible, left hand	CSZZ-7627847-AR
65-66 Fastback, 1 piece right hand .....	CSZZ-6327846-C
65-66 Fastback, 1 piece left hand .....	CSZZ-6327847-C
67 Fastback, 1 piece right hand .....	C7ZZ-6327846-CR
67 Fastback, 1 piece left hand .....	C7ZZ-6327847-CR
67 Coupe, right hand, with louver holes .....	C7ZZ-6527846-A
67 Coupe, left hand, with louver holes .....	C7ZZ-6527847-A
67 Convertible, right hand, with louver holes	C7ZZ-7627846-C
67 Convertible, left hand, with louver holes	C7ZZ-7627847-C
68 Fastback, right hand ...	C8ZZ-6327846-A
68 Fastback, left hand .....	C8ZZ-6327847-A
68 Coupe, right hand (w/ out indent) .....	C8ZZ-6527846-A
68 Coupe, left hand (w/out indent) .....	C8ZZ-6527847-A
68 Convertible w/ indent, Right Hand .....	C8ZZ-7627846-A
68 Convertible w/out indent, Right Hand ...	C8ZZ-7627846-B
68 Convertible w/ indent, Left Hand .....	C8ZZ-7627847-A
68 Convertible w/out indent, Left Hand .....	C8ZZ-7627847-B
69 Fastback, right hand ..	C9ZZ-6327846-CR
69 Fastback, left hand .....	C9ZZ-6327847-CR
70 Fastback, right hand ...	D0ZZ-6327846-A
70 Fastback, left hand .....	D0ZZ-6327847-A

### **QUARTER PANEL EXTENSION**

#### **Quarter Panel Extension.**

#### **Quarter Panel Extension**

	64-66: Right hand CSZZ-6527702-A
	64-66: Left hand CSZZ-6527703-A
	67-68: Fastback, right hand C7ZZ-6327702-A

#### **Quarter Panel Extension**

	67-68: Fastback, left hand C7ZZ-6327703-A
	67-68: Coupe and convertible, right hand C7ZZ-6527702-A
	67-68: Coupe and convertible, left hand C7ZZ-6527703-A
	69: Fastback, right hand C9ZZ-6328010-A
	69: Fastback, left hand C9ZZ-6328011-A
	70: Fastback, right hand D0ZZ-6328010-A
	70: Fastback, left hand D0ZZ-6328011-A
	71-72: Coupe, right hand D1ZZ-6527702-A
	71-72: Coupe, left hand D1ZZ-6527703-A
	71-73: Fastback, right hand D1ZZ-6328010-A
	71-73: Fastback, left hand D1ZZ-6328011-A

**QUARTER PANEL EXTENSION NUT**



Concours correct, set of 6. Will also fit 69-70.

**Quarter Panel Extension Nut**  
64-68 Set of 6 .....373556-S

**QUARTER PANEL SKIN**



Our replacement skins eliminate much of the demolition work that accompanies complete quarter panel replacement.

**Quarter Panel Skin**  
65-66 Right hand .....C5ZZ-6527846-S  
65-66 Left hand .....C5ZZ-6527847-S  
67-68 Right hand, without holes .....  
C7ZZ-6527840-S  
67-68 Left hand, without holes .....  
C7ZZ-6527841-S  
69 Coupe and convertible, right hand .....  
C9ZZ-6527840-S  
69 Coupe and convertible, left hand .....  
C9ZZ-6527841-S  
69-70 Fastback, right hand, without any holes  
C9ZZ-6327840-S  
69-70 Fastback, left hand, without any holes ...  
C9ZZ-6327841-S  
70 Convertible, right hand. Modify for  
Coupe. ....D0ZZ-6527840-S  
70 Convertible, left hand. Modify for Coupe.  
D0ZZ-6527841-S  
71-73 Coupe and convertible, right hand .....  
D1ZZ-6527846-S  
71-73 Coupe and convertible, left hand .....  
D1ZZ-6527847-S  
73 Fastback, right hand ... D3ZZ-6327846-S  
73 Fastback, left hand .... D3ZZ-6327847-S

**UPPER QUARTER VENT LOUVERS**



**Quarter Vent Louvers, Upper**  
67-68 ..... C7ZZ-63280B62-K

**REAR SPOILER**



This wing is made of strong fiberglass. Finished smooth with dull Black paint. Complete kit includes Spoiler, pedestals, pads

& mounting hardware.

**Rear Spoiler**  
69-70 ..... C9ZZ-6344210-K  
71-73 Blemished .....D1ZZ-6344210-BK  
71-73 ..... D1ZZ-6344210-K

**REAR SPOILER MOUNTING BRACKET**



Brackets used to mount the rear spoiler to the deck lid.

**Rear Spoiler Mounting Bracket**  
69-70 ..... C9ZZ-6344220-B

**REAR SPOILER MOUNTING GASKET**



Now made by Scott Drake. Our gaskets are made of high quality EPDM rubber to provide years of service. Not just a flat piece of rubber. These pads are formed to fit the slope of the trunk lid. Sold in matching pairs.

**Rear Spoiler Mounting Gasket**  
69-73 ..... C9ZZ-6344228/9A

**REAR SPOILER MOUNTING HARDWARE KIT**



The bases are made from our own tooling with high quality zinc. Our kit also features stainless steel and zinc plated hardware for

years of service. The pads are a Scott Drake exclusive and made of high quality EPDM rubber. Also available for 1971-73 applications.  
**Rear Spoiler Mounting Hardware Kit**  
69-70 .....C9ZZ-6344210-HD  
71-73 .....D1ZZ-6344210-HD

**REAR VALANCE**



These stampings are painted black for corrosion protection.

**Rear Valance**  
64-66 No holes ..... C5ZZ-6540544-AR  
64-66 With backup light holes .....  
C5ZZ-6540544-BR  
65-66 GT with back up light holes.....  
C5ZZ-6540544-CR  
65-66 GT with back up light holes .....  
C5ZZ-6540544-DR  
67-68 .....C7ZZ-6540544-CR  
67-68 GT ..... C7ZZ-6540544-DR

**Rear Valance**

69-70 ..... C9ZZ-6540544-AR  
69-70 GT / Mach 1 ..... C9ZZ-6540544-BR  
71-73 ..... D1ZZ-6540544-AR  
71-73 Mach 1 ..... D1ZZ-6540544-BR

**REAR WHEEL FLARE**



Covers the upper section of the wheel opening. Offset on top edge for easier installation. Overlaps the lower rear quarter

when both are used.

**Rear Wheel Flare**  
69-70 Left hand ..... M301LH  
69-70 Right hand ..... M301RH

**REAR WINDOW LOUVER BOTTOM**

**LATCH**



These are very nice reproductions. Sold in pairs.

**Rear Window Louver Bottom Latch**  
69-70 .....C9ZZ-6344268-L

**REAR WINDOW LOUVER KIT**



Complete kit includes louvers, hinges, latches, gaskets and pads.

**Rear Window Louver Kit**  
69-70 ..... C9ZZ-6344268-K

**REAR WINDOW LOUVER PAD**

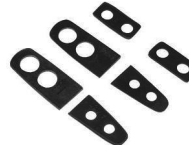

Gaskets or pads to protect the paint when installing the rear window louvers.

**Rear Window Louver Pad**  
69-70 6 pieces ..... C9ZZ-6344268

**REAR WINDOW LOUVER SEAL**



Seals and insulates the rear window louvers to the car.

**Rear Window Louver Seal**  
69-70 .....C9ZZ-6344268-S

Sheet Metal

**WE PROUDLY FEATURE AUTHENTIC MUSTANG REPRODUCTIONS FROM SCOTT DRAKE ENTERPRISES!**



## REAR WINDOW LOUVER UPPER HINGES



Hinges to attach the rear louvers and allow them to be raised for cleaning. Polished chrome finish.

Rear Window Louver Upper Hinges  
69-70 ..... C9ZZ-6344268-H

## ROOF BRACE FRONT

Front support brace for the roof on coupes and fastbacks.



Roof Brace Front  
65-68 Front ..... CSZZ-6552103-A

## ROOF BRACE REAR

Support brace for the rear of the roof.



Roof brace Rear  
67-68 Fastback ..... C7ZZ-6552104-A

## FASTBACK ROOF PANEL



Complete Fastback roof panels. Includes outer frame work underneath. Does not include front or rear brace.

Roof Panel, Fastback  
65-66 ..... CSZZ-6350202-A  
67-68 ..... C7ZZ-6350202-A  
69-70 ..... C9ZZ-6350202-A

## SHELBY SIDE SCOOP



A quality reproduction of the Shelby Side Scoops. Ready to fit and paint.

Side Scoop, Shelby  
65-66 ..... S1MS-6529076/7

## TAIL LIGHT HONEYCOMB PANEL



All new tooling, made exclusively for Scott Drake. High quality plastic injection part made from ABS plastic. For molding please see

molding section.  
Tail Light Honeycomb Panel  
70 Dark Argent ..... D0ZZ-63423B70

## Tail Light Honeycomb Panel

71-73 Black ..... D1ZZ-63423B70

## TAIL LIGHT PANEL



Carefully formed to facilitate a painless replacement, these panels offer an affordable repair for damaged originals.

## Tail Light Panel

64-66 OEM tooling ..... C6ZZ-6540324-A  
64-66 U.S.A. made ..... C6ZZ-6540324-AR  
64-66 Quality Import ..... C6ZZ-6540324-AT  
67-68 ..... C7ZZ-6540324-AR  
68 Use w/ Shelby lights ..... C8ZX-6540324  
69 ..... C9ZZ-6540324-AR  
70 ..... D0ZZ-6540324-BR  
71-73 ..... D1ZZ-6540324-AR

## TAIL LIGHT PANEL WITH CORNER DRIP RAILS



Includes Coupe/Convertible trunk corner unattached.

## Tail Light Panel With Corner Drip Rails

67-68 Coupe & Convertible ... C7ZZ-6540324-K

## FASTBACK TAIL LIGHT PANEL BRACKET



Panel to secure tail light panel to quarter panel.

## Tail Light Panel Bracket, Fastback

65-66 Right hand ..... CSZZ-6328058-A  
65-66 Left hand ..... CSZZ-6328059-A  
67-68 Fastback, Right hand .. C7ZZ-6328058-A  
67-68 Fastback, Left hand ..... C7ZZ-6328059-A  
69-70 Fastback, Right hand .. C9ZZ-6328058-A  
69-70 Fastback, Left hand ..... C9ZZ-6328059-A

## TAIL LIGHT PANEL BRACKET AND BRACE



Must be welded in to place. Painted black to resist corrosion.

## Tail Light Panel Bracket And Brace

64-66 Coupe and Fastback .... CSZZ-6543236-A  
64-66 Convertible ..... CSZZ-7643235-A  
67-68 ..... C7ZZ-6543236-A  
69-70 ..... D0ZZ-6543236-A

## FASTBACK TRUNK LID FILL PANEL



This commonly rusted part fits between the rear window and the trunk lid. Finished in semi-gloss primer epoxy.

## Trunk Lid Fill Panel, Fastback

65-66 ..... CSZZ-6340310-A  
67-68 ..... M3647  
69-70 ..... M-328-FB

## WHEELHOUSE AND TRUNK

### REAR CROSS MEMBER



This brace is often damaged when rearended. Attaches to tail light panel. Gas tank rests on lip.

## Rear Cross Member

64-70 Cross Member ..... CSZZ-7610780-BR

### CONVERTIBLE TRUNK BRACE



For best results when replacing the crossmember, it is best to replace these pieces as well.

## Trunk Brace, Convertible

64-70 Center piece only ..... M135A  
64-70 Left hand only ..... M135ALC  
64-70 Right hand only ..... M135ARC

### CONVERTIBLE TRUNK BRACE AND CROSS MEMBER



This set includes the Mustang rear cross member and convertible trunk brace pre-assembled for easy installation.

Also includes LH and RH brace pieces.

## Trunk Brace and Cross Member, Convertible

64-70 ..... CSZZ-7610780-B

### TRUNK BUMPER BRACE



Welded to trunk floor, rear bumper bracket attaches to them.

## Trunk Bumper Brace

64-66 Left hand ..... MM134BL  
64-66 Right hand ..... MM134BR  
67-68 Right hand or left hand ..... MM634LR  
69-70 Right hand or left hand ..... MM667LH

## TRUNK DIVIDER AND PACKAGE SHELF

Replacement sheetmetal for behind rear seat. Original package tray with upgraded steel rear seat divider for coupes.

Trunk Divider and Package shelf



65-68: Coupe  
CSZZ-6562118-A



67-68: Fastback  
C7ZZ-6346610-A



69-70: Fastback  
C9ZZ-6346510-A

## TRUNK FLOOR

Trunk Floor



64-70: Right hand, economy  
CSZZ-6511218-A



64-70: Left hand economy  
CSZZ-6511219-A



71-73: 54" W X 38" L, complete  
M438

## COMPLETE TRUNK FLOOR



These are quality, steel replacements. These are complete trunk floors. Includes drop offs. Convertibles will require trunk brace.

Trunk Floor, Complete

65-66 Complete ..... CSZZ-6511215-A  
67-68 Complete ..... C7ZZ-6511215-A  
69-70 Complete ..... C9ZZ-6511218/9

## TRUNK FLOOR DROP OFF



This drop off meets the bottom section of the quarter panel. Overlaps the trunk floor 1". This is included when buying a trunk floor. MADE IN THE U.S.A. 1969 - 1970 requires

trimming.

trimming.

Trunk Floor Drop Off

64-70 Left hand, 21" W x 9" L ..... M109LH  
64-70 Right hand, 21" W x 9" L ..... M109RH  
71-73 Left hand, 20 1/4" W x 9" L ..... M409LH  
71-73 Right hand, 20 1/4" W x 9" L ..... M409RH

## TRUNK LID

Good quality import Trunk Lid. Ready to paint and install.



Trunk Lid

64-66 Coupe and convertible CSZZ-6540110-CR  
65-66 Fastback ..... CSZZ-6340110-A  
67-68 Fastback ..... C7ZZ-6340110-AR  
67-68 Coupe and convertible C7ZZ-6540110-CR  
69-70 Fastback ..... C9ZZ-6340110-CR

## TRUNK LID AND QUARTER EXTENSIONS



Trunk lid and quarter panel extensions for Shelby and California Special. Reproduced just

like original.

67-68 Shelby Convertible & California Special C8ZX-6540110-K  
67-68 Fastback, trunk lid only S7MS-6340110-K  
67-68 Fastback, 1/4 extensions S7MS-6327702/3

## TRUNK LID HINGE



Now you can replace those bent, and or rusted trunk hinges and get the original fit and alignment. Sold as a pair.

Trunk Lid Hinge

67-68 Fastback ..... C7ZZ-6342700/1A  
69-70 Fastback ..... C9ZZ-6342700/1A

## TRUNK LID PROP ROD



Our steel prop rod is zinc plated for years of service. We include the storage clip and the retaining clip for a quick and complete

installation. A must when using a rear spoiler.

Trunk Lid Prop Rod

69-70 ..... C9ZZ-6344206

## TRUNK PANEL

Goes between the fuel tank and the rear seat in the trunk area.



Trunk Panel

64-68 ..... M135TP

## TRUNK REAR CORNER



Corner pieces for where the quarter panel and taillight meet. Part of the rain gutter. Important replacement when

changing the quarter panels. Coupes and convertibles only. Made in the U.S.A.

Trunk Rear Corner

64-66 Coupe and convertible, Left hand ..... M142LH

64-66 Coupe and convertible, Right hand ..... M142RH

67-68 Coupe and convertible, Left hand ..... M242LH

67-68 Fastback, LH ..... M242LH-FB

67-68 Coupe and convertible, Right hand ..... M242RH

67-68 Fastback, RH ..... M242RH-FB

## COMPLETE WHEELHOUSE



Previously available only separately, these complete wheel housings are made of high quality, formed sheet metal. Finished

in black satin paint for corrosion protection. Available in right and left sides. Must modify for convertibles.

Wheelhouse, Complete

65-66 Right hand ..... CSZZ-6527886/94

65-66 Left hand ..... CSZZ-6527887/95

67-68 Right hand ..... C7ZZ-6527886/94

67-68 Left hand ..... C7ZZ-6527887/95

69-70 Right hand ..... C9ZZ-6527886/94

69-70 Left hand ..... C9ZZ-6527887/95

## INNER WHEELHOUSE



Fits coupe and fastback, but must be modified for convertible to allow the top to nest properly. The seam

needs to be bent over and the inner section flattened.

Wheelhouse, Inner

64-70 Right hand ..... CSZZ-6527886-A

64-70 Left hand ..... CSZZ-6527887-A

71-73 Left hand ..... D1ZZ-6527887-A

Sheet Metal

WE PROUDLY FEATURE AUTHENTIC MUSTANG REPRODUCTIONS FROM SCOTT DRAKE ENTERPRISES!



189

**Wheelhouse, Inner**  
71-73 Right hand .....D1ZZ-6527886-A

**OUTER WHEELHOUSE**



A quality stamping now available.

**Wheelhouse, Outer**  
64-66 Left hand ..... M113LH  
64-66 Right hand ..... M113RH  
67-68 Left hand ..... M213LH  
67-68 Right hand ..... M213RH  
69-70 Left hand ..... M313LH  
69-70 Right hand ..... M313RH  
71-73 Left hand ..... M413LH  
71-73 Right hand ..... M413RH

**PARTIAL OUTER WHEELHOUSE**



Rear section of outer wheelhouse, a commonly rusted area.

**Wheelhouse, Partial Outer**  
64-66 Left hand .....M113ALH  
64-66 Right hand ..... M113ARH

**STEERING**

**CENTER LINKS**

**STEERING CENTER LINK**



Popular replacement item. Commonly bent or worn out.

**Steering Center Link**  
64-66 6 cylinder, manual steering C5ZZ-3304-EI  
64-66 V8, manual steering .....C5ZZ-3304-CI  
65-66 V8, without control valve . C5ZZ-3304-DI  
67-69 6 and 8 cylinder, manual steering .....  
C7Z-3304-CI  
70 Manual ..... D0ZZ-3304-CI

**IDLER AND PITMAN ARMS**

**IDLER ARM**



Forged iron replacement arms. Kits include bushings and hardware.

**Idler Arm**  
64-66 6 cylinder, manual steering C3DZ-3352-L  
64-66 6 cylinder, power steering .C4DZ-3352-B  
64-66 V8, manual or power steering .....  
C5ZZ-3352-BR  
67-70 Power steering. One piece design. ....  
C7Z-3350-AR  
67-70 Manual steering .....C7Z-3350-BR  
67-70 Power steering. Two piece design. ....  
C7Z-3350-CR  
71-73 Power steering. Two piece design. ....  
D1ZZ-3350-AR

**IDLER ARM BRACKET**



Forged construction.

**Idler Arm Bracket**  
64-66 260, 289 .....C3DZ-3351-A

**IDLER ARM BUSHING**



These quality replacements are American made. Steel shell and tube. Fits original Ford idler arms only.

**Idler Arm Bushing**  
64-66 Power steering ..... C3DZ-3356-AR  
64-66 Manual steering .....C5ZZ-3356-AR  
67-70 Power steering, upper .... C70Z-3356-AR

**IDLER ARM MOUNT KIT**



Concours correct mounting kit for 1964-68 Mustangs. Will also fit 1969-70 Mustangs but not concours.

**Idler Arm Mount Kit**  
64-68 .....378405-S

**PITMAN ARM**



Forged arm replaces worn originals very nicely.

**Pitman Arm**  
64-66 V8, power steering ..... C5ZZ-3590-A

**Pitman Arm**  
67 ..... C7ZZ-3590-B

**POWER STEERING**

**CONTROL VALVE TO CYLINDER HOSE**



These are the short hoses which connect the control valve to the power cylinder. Both are high pressure with correct fittings. These

are not one size fits all like ones from the Auto Parts store. Correct upper and lower hoses.

Concours correct, made by Drake!

**Control Valve to Cylinder Hose**

64-66 Concours, set of 2 ..... C3DZ-3A714/7-AR  
67-70 Concours, set of 2 ..... C60Z-3A714/7-AR

**POWER STEERING BALL AND STUD REPAIR KIT**



Includes ball and stud kit and all seals necessary to stop leaks and reduce excess play in steering wheel.

**Power Steering Ball and Stud Repair Kit**  
64-70 ..... C2AZ-3A533-A

**POWER STEERING CONTROL VALVE**



**Power Steering Control Valve**  
64-66 V8 ..... C5ZZ-3A730-N  
67-70 5/16" Port ..... C8ZZ-3A730-SS

**POWER STEERING CONTROL VALVE SEAL KIT**

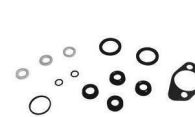

Includes all seals, gaskets and "O" rings needed to stop leaks. Makes your control valve perform properly.

**Power Steering Control Valve Seal Kit**  
64-70 ..... C3AZ-3A650-A

**POWER STEERING CONVERSION KIT**

Drake now offers an integral power steering conversion for your 1965-70 Classic Mustang. The conversion box is a remanufactured modern integral power steering gearbox. It provides true modern power steering

feel, feedback and sporty 16:1 ratio. It has been remanufactured to bolt directly to the factory mounting location and to fit the stock pitman arm without any interference or modification of the shock tower. 1965-67 Mustangs will require replacing column shaft. 68-70 Mustangs will need the factory column collapsed 1-2" for clearance. Eliminate your leaky control valve and sloppy steering. Feel the road with our new integral power steering conversion kits. We offer both Kits to convert from MS to PS and Factory PS to PS. Please note Factory Ford Pumps work fine with these Kits above Idle but will offer very little power assist under 800 RPM's. We can special order a PS to PS Kit with a modern Saginaw Pump that is more effective at Lower RPM's. Note: Manual Transmission cars must run a special Clutch Equalizer Bar or a Clutch Cable Set-Up, both are available in the Transmission section (Big Block Equalizer not available at this time). Due to the fact that there are 8 possible kits for 1967, some will cross-over to listed kits, and others are available as special order, so please call. 6-cylinder kits available as Special order, so please call.

**Power Steering Conversion Kit**



64-66: V8, Manual Steering to Power Steering  
CSZZ-MS-PS-CK



64-66: V8, Power Steering to Power Steering  
CSZZ-PS-PS-CK



67-70: Late 67: Small Block; 68-70: 289, 302, 351W; Manual Steering to Power Steering  
C8ZZ-MS-PS-CK



67-70: Late 67: Small Block; 68-70: 289, 302, 351W; Power Steering to Power Steering  
C8ZZ-PS-PS-CK

**POWER STEERING CYLINDER**

These brand new steering cylinder are pressure tested. No core is necessary on these.



**Power Steering Cylinder**

64-66 .....C3DZ-3A540-B  
67-70 .....C3DZ-3A540-A

**POWER STEERING CYLINDER BOOT AND CLAMP**



Compression molded rubber grease and corrosion resistant. Special locking metal band that fits around power steering ram

boot.  
**Power Steering Cylinder Boot and Clamp**  
64-70 .....CSZZ-3A540-B

**POWER STEERING CYLINDER BOOT KIT**



Our boot kit includes exact OE washers, steel tube spacer and high quality EPDM rubber bushings and boot.

**Power Steering Cylinder Boot Kit**  
64-70 .....C60Z-3C651-A

**POWER STEERING CYLINDER SEAL KIT**



Kit includes all repair parts necessary to refurbish leaking cylinder/piston rod seal area.

**Power Steering Cylinder Seal Kit**  
64-70 .....C1AZ-3A764-A

**POWER STEERING SOCKET SLEEVE**



This bronze/steel sleeve should be replaced to do a proper rebuild on your control valve.

**Power Steering Socket Sleeve**  
65-70 .....C1AA-3A754-C

**POWER STEERING DROP BRACKET**



A must when using full length headers, including Tri-Y's, on a power steering car. Lowers power steering for proper clearance

when using Tri-Y headers. Now made by Drake, this part features thicker metal and better welds!  
**Power Steering Drop Bracket**  
64-70 .....DBPP-10961-A

**POWER STEERING FRAME RAIL COMPRESSION NUTS**



These compression nuts are needed when installing power steering into manual steering cars. Installation Kit,

375474-IK required for proper install.  
**Note: Nuts are oversized and require opening up holes in the frame rail.**

**Power Steering Frame Rail Compression Nuts**  
64-70 Pair of compression nuts .....375474-SK  
64-70 Installation Kit .....375474-IK

**PRESSURE POWER STEERING HOSE**



A power steering hose just has to fit, and you will find that our new concours correct hoses not only have the correct, pre-bent ends,

they have the "step down" size so they work just like the originals. We also offer aftermarket replacements for less popular applications.

**Power Steering Hose, Pressure**

64 200, with Ford pump .....C5DZ-3A719-A  
64-65 260, with Ford pump .....CSZZ-3A719-A  
65-66 289, with Ford pump .....CSZZ-3A719-D  
64-65 260, 289, with Eaton pump .....  
.....CSZZ-3A719-E

67 200, 1/4 inch control valve fitting .....  
.....C70Z-3A719-A

67 289, 1/4 inch control valve fitting .....  
.....C70Z-3A719-C

67-68 289, 302, 5/16 inch control valve fitting ..  
.....C70Z-3A719-D

67-70 390, 428 valve end, 5/16 inch fitting .....  
.....C7ZZ-3494-A

69-70 302, 351 valve end, 5/16 inch fitting ....  
C7ZZ-3494-A

67-70 390, 428, pump end .....C7ZZ-3A719-B  
67-68 200, 250, 5/16 inch control valve fitting ..  
.....C80Z-3A719-B

69 302, 351, pump end, without cooler .....  
.....C9ZZ-3A719-A

69 302, pump end, with cooler .....  
.....C9ZZ-3A719-C

70 302, 351, pump end, without cooler .....  
.....D00Z-3A719-E

71-72 302, 351, before 5-1-72 ..D1ZZ-3A719-C  
71-73 302, 351, after 5-1-72 ... D1ZZ-3A719-A

Steering

**WE PROUDLY FEATURE AUTHENTIC MUSTANG REPRODUCTIONS FROM SCOTT DRAKE ENTERPRISES!**



191



**RETURN POWER STEERING HOSE**

Our 64-68 Small Block return hoses are exact copies of the original. We used Ford prints to assure a perfect fit.

**Power Steering Hose, Return**

64-66 260, 289 .....	C5DZ-3A713-D
67-70 200, 289, 302 .....	C70Z-3A713-A
67-70 67-70 BB & 69-70 SB .....	C70Z-3A713-C
71-73 250, 302, 351, without air .....	D12Z-3A713-A

**POWER STEERING HOSE BRACKET**

Die stamped metal construction. Insulators not included.

**Power Steering Hose Bracket**

64-66 .....	C5DZ-3A609/1-A
67-68 .....	C7DZ-3A609/1-A

**POWER STEERING HOSE INSULATOR**

Made from molded rubber that is specially blended to resist hardening and cracking.

**Power Steering Hose Insulator**

64-66 .....	C20Z-3A609-A
67-70 .....	C7ZZ-3A609-A

**POWER STEERING MOUNT BOLT**

Concours correct for 1967-69 Mustangs.

**Power Steering Mount Bolt**

67-69 .....	377060-S
-------------	----------

**POWER STEERING PUMP ADJUSTER BRACKET**

Used in conjunction with C7ZZ-3A732-B Bracket.

**Power Steering Pump Adjuster Bracket**

67-69 289, 302 .....	C7SZ-3A732-A
----------------------	--------------

**POWER STEERING PUMP CAP**

w/ Dipstick, Eaton pump

**Power Steering Pump Cap**

64-65 Zinc, with dipstick, Eaton pump .....	C3AZ-3A006-A
64-65 Chrome, with dipstick, Eaton pump .....	C3AZ-3A006-C
64-66 Zinc, concours, without dipstick .....	C5AZ-3A006-B
65-66 Billet w/out Stick .....	B-3A006-A
65-66 Billet w/ stick .....	B-3A006-B
65-66 Chrome, concours, without dipstick .....	C5AZ-3A006-B
65-66 Zinc, concours, with dipstick .....	C5AZ-3A006-C
65-66 Chrome, concours, with dipstick .....	C5AZ-3A006-C

**POWER STEERING PUMP DIPSTICK**

Excellent reproductions with high level of detail. Both feature the FoMoCo logo.

**Power Steering Pump Dipstick**

67-70 Billet w/ Stick .....	B-3A006-C
67-73 Zinc, concours* .....	C7AZ-3A006-B
67-73 Chrome, concours* .....	C7AZ-3A006-B

**POWER STEERING PUMP HOUSING**

Power steering canister/pump housing for Ford style pump. This canister has the neck angled back to clear the A/C compressor and will fit non A/C cars also. Comes with a seal and needs to be painted. Will not fit w/ modern Sanden-style A/C conversions. Will clear OEM York compressors.

**Power Steering Pump Housing**

64-66 .....	C5DZ-3A697-C
-------------	--------------

**POWER STEERING PUMP MOUNTING BRACKET****Power Steering Pump Mounting Bracket**

65-66 289, Ford pump .....	C5AZ-3A732-B
67-69 289, 302, 351, 390, 428 ..	C7ZZ-3A732-B

**POWER STEERING PUMP SEAL KIT**

Provides everything needed to do a pump rebuild.

**Power Steering Pump Seal Kit**

64-65 Eaton pump .....	C2AZ-3B584-AR
65-73 Ford pump .....	D1AZ-3B584-A

**POWER STEERING TO FRAME BUSHING**

Improves steering response. Made from polyurethane, these bushings are long lasting and firmer than stock.

**Power Steering to Frame Bushing**

64-66 .....	C5ZZ-3A344-P
67-70 .....	C7ZZ-3A344-P

**TILT AWAY STEERING VACUUM CANISTER**

Mounts to rear passenger side fender apron. Hold vacuum pressure to operate tilt away switch when car is turned off.

**Tilt Away Steering Vacuum Canister**

67-69 1 port .....	C7ZZ-3E547-A
67-69 2 ports .....	C7ZZ-3E547-B

**RACK AND PINION****MANUAL STEERING ADAPTER****C5ZZ****Manual Steering Adapter**

67-70 All .....	C7ZZ-3304-AD
-----------------	--------------

**FLAMING RIVER RACK AND PINION KIT**

Manual steering that feels like power steering. Easy installation that maintains the original suspension.

No welding. No fabrication. Due to many variations, we recommend contacting us with your specific application to assure the correct kit. Tilt columns for original steering wheel are available as a special order. Power Steering Kit available as a special order.

**Rack and Pinion Kit, Flaming River**

64-69 Rack and pinion, stock spindles, stock exhaust manifolds, no tilt column. Modify factory column. ....CSZZ-3304-RPSM

64-69 Rack & pinion, Granada spindles, stock exhaust manifolds, w/ paintable tilt column. Aftmrkt wheel. CSZZ-3304-RPK

64-70 Small block, w/ headers, no tilt column. Modify factory column. CSZZ-3304-RPSH

64-69 SB, w/ headers, w/ paintable tilt column. Aftermarket wheel.....CSZZ-3304-RPSHK

**STEERING COLUMNS**

**LOWER STEERING COLUMN COVER**



A very nice reproduction of a commonly broken part.

**Lower Steering Column Cover**

69 .....C9ZZ-6504459-BK  
70 .....D0ZZ-6504459-BK  
71-73 .....D1ZZ-6504459

**STEERING COLUMN TO FIREWALL COLLAR**



This steel collar is typically rusted, from it damp location and rubber seal usually cracked and ineffective. Save time

and trouble trying to restore your old one. Rubber Collar Seal included as well.

**Steering Column to Firewall Collar**

67-68 .....C7ZZ-3B633-A

**STEERING COLUMN TO FIREWALL SEAL**



These high quality parts assure the restorer of a water-tight seal where the steering column passes through the

firewall.

**Steering Column to Firewall Seal**

64-66 .....C5ZZ-3513  
67-68 .....C7ZZ-3513  
69-70 .....C9ZZ-3513  
71-73 Auto .....D1ZZ-3513  
71-73 Manual.....D1ZZ-3513-A

**STEERING COLUMN TO FLOOR GROMMET**



Molded rubber. Mounts on steering column over carpet.

**Steering Column to Floor Grommet**

65-67 .....B5S-3512

**STEERING COLUMN TO GEAR BOX INSULATOR**



**Steering Column to Gear Box Insulator**

64-67 .....C60Z-3564

**STEERING SHAFT SPRING**



This is the spring that goes over the shaft and inside the collar to provide spring tension on the bushing to keep the shaft centered in

the column.

**Steering Shaft Spring**

64-67 .....C3DZ-3520-A  
64-67 Bushing.....B1AZ-3518-A

**FLAMING RIVER TILT STEERING COLUMN**



Available in paintable steel or polished stainless steel. Requires mounting kit. Will fit 1970 cars but relocation of ignition

switch is required. These fit original steering boxes only. Modifications required to 64-67E shaft. Original versions have original Ford splines to accept factory wheels. The below Tilt Steering Columns are for use with factory steering boxes only and are not to be used with rack & pinion kits. Rack & pinion kits are available as a Special Order, add "-RP" to the end of the appropriate part number below. Prices are the same provided it can be added to our next stocking order, otherwise additional freight charges will apply.

**Tilt Steering Column, Flaming River**

65-66 For Grant wheels only ... C5ZZ-3514-AFT  
65-66 For Grant wheel, stainless steel .....C5ZZ-3514-AFT-S

65-66 For original wheel .....C5ZZ-3514-OEM

67-69 For Grant wheels only ... C7ZZ-3514-AFT

67-69 For Grant wheel, stainless steel .....C7ZZ-3514-AFT-S

**Tilt Steering Column, Flaming River**

67-69 For original wheel .....C7ZZ-3514-OEM

**IDIDIT TILT STEERING COLUMN**



ididit introduces the first Ford Top Shaft and Ford Turn Signal Switch tilt steering column for 1965-69 Mustangs! This made

to fit column will include a special new floor mount, 8-position tilt, Mustang style knobs & handles and male & female plugs with terminals. ididit's new Mustang column will accept a stock Mustang steering wheel or an aftermarket wheel with an adaptor. By using the stock underdash mount and a coupler (sold separately), the installation is a breeze! The new 8-position tilt 1965-69 Mustang column is available in Paintable Steel, Chrome and Black Powder Coated. Lower shaft is 3/4" 36. Don't forget your installation kit, each installation kit from ididit is specific to your Mustang application. Each ididit column is 100% American Made. Note: 65-67E require cutting original shaft. The below part numbers are for use with stock steering boxes. For Rack and Pinion add "-RP" which are available as a Special Order for \$25 more.

**Tilt Steering Column, ididit**

65-66 Black .....C5ZZ-3514-B

65-66 Chrome .....C5ZZ-3514-C

65-66 Paintable steel .....C5ZZ-3514-S

65-66 Paintable Steel, with Rack & Pinion .....C5ZZ-3514-S-RP

67 Black .....C7ZZ-3514-B

67 Chrome .....C7ZZ-3514-C

67 Paintable steel .....C7ZZ-3514-S

67 Paintable Steel, with Rack & Pinion .....C7ZZ-3514-S-RP

68-69 Black .....C8ZZ-3514-B

68-69 Chrome .....C8ZZ-3514-C

68-69 Paintable steel .....C8ZZ-3514-S

68-69 Paintable Steel, with Rack & Pinion .....C8ZZ-3514-S-RP

**FLAMING RIVER TILT STEERING COLUMN MOUNT KIT**



This kit includes all components to install a Flaming River" tilt column.

**Tilt Steering Column Mount Kit, Flaming River**

65-67 .....C5ZZ-3514-MK

67-70 .....C7ZZ-3514-MK

**WE PROUDLY FEATURE AUTHENTIC MUSTANG REPRODUCTIONS FROM SCOTT DRAKE ENTERPRISES!**



## **IDIDIT TILT STEERING COLUMN MOUNT KIT**



These kits include the components needed to install your ididit Tilt Steering Column.

<b>Tilt Steering Column Mount Kit, ididit</b>	
65-67	.....C5Z-3514-IK
67-68	.....C7Z-3514-IK
69	.....C9Z-3514-IK

## **STEERING COUPLERS**

### **STEERING COUPLER**



This steering coupler, commonly referred to as a "rag joint", connects the steering shaft to the input shaft on the steering box.

<b>Steering Coupler</b>	
67-73 Polyurethane	.....C7OZ-3A525-P
67-70 Rubber	.....C7OZ-3A525-R

### **STEERING COUPLER BOLT AND NUT**



Concours correct. Two required per car.

<b>Steering Coupler Bolt and Nut</b>	
68-70	.....C8OZ-3A525

## **STEERING GEAR BOXES**

### **NEW GEAR BOX**



These all new boxes feature a improved needle bearing design for smoother operation. They are a direct bolt in, no

modifications required. Early 67 have 1" sector shaft. Late 67 Ford switched to 1 1/8" sector shaft. **Note: Quick 16:1 ratio used on power steering and performance models w/ manual steering.**

<b>Gear Box, New</b>	
64-67 16:1 ratio, power steering, long shaft	.....C5Z-3548-P
67 16:1 ratio, short shaft 1" sector	.....C7Z-3548-P
68-70 16:1 ratio, short shaft 1 1/8" sector	.....C8Z-3548-P

## **GEAR BOX COVER SEAL**



A leak coming from the steering box can sometimes be traced to the gasket at the steering box cover.

<b>Gear Box Cover Seal</b>	
64-70	.....C3DZ-3581-A

## **STEERING BOX FRAME BOLTS AND WASHERS**

Concours correct for 1964-68 Mustangs. Will also fit 69-70 but not concours. **Steering Box Frame Bolts and Washers**



64-68: Bolts only  
378331-5



64-68: Washers only  
378581-5

## **STEERING BOX REBUILD KIT**



This steering box rebuild kit can tighten up that loose, drifting feeling. Cover seal sold separately under part #C3DZ-3581-A.

<b>Steering Box Rebuild Kit</b>	
64-67 1 inch	.....C5Z-3548-RK
67-70 1 1/8 inch	.....C7Z-3548-RK

## **STEERING WHEEL HORNS**

### **HORN BUTTON RUBBER SPRING PAD**



This is the oe rubber pad that is typically smashed in the horn button.

<b>Horn Button Rubber Spring Pad</b>	
64-67	.....C0DZ-13A813-A

### **HORN BUTTON SPRING**



Wire spring used with horn ring. Painted. Not used on 65-67 deluxe wood wheel or 69 rim blow wheel.

<b>Horn Button Spring</b>	
65-69	.....C0DZ-13A807-B

## **HORN CONTACT INSULATOR**



Replace that broken insulator with this new part.

<b>Horn Contact Insulator</b>	
67	Excluding wood wheels C7AZ-13A903-B

## **HORN CONTACT SPRING**

2 required per car.



<b>Horn Contact Spring</b>	
64	Original style .....C2OZ-13A821-A

## **HORN LENS INSULATOR**



This foam pad goes between the lens and body of the center cap on the deluxe steering wheel.

<b>Horn Lens Insulator</b>	
65-66 Deluxe	.....C5Z-13A816-A

## **RIM BLOW HORN PAD**



The center pad that covers the spokes of the steering wheel.

<b>Horn Pad, Rim Blow</b>	
69	Black Deluxe .....C9Z-3623
70-73	Black Deluxe .....D0ZZ-3623-A

## **HORN PANEL BEZEL**



Plastic injection and chrome plated. Fits in center of steering wheel, holds vinyl pad and buttons.

<b>Horn Panel Bezel</b>	
68-69	.....C8Z-3D572-AR

## **HORN PANEL BEZEL BUTTON**



Chromed Plastic buttons with textured black centers. Set of 6. See emblem section for center medallion. Standard button.

<b>Horn Panel Bezel Button</b>	
68-69	Set of 6 .....C8Z-3600-AR

### HORN PANEL PAD

Vinyl pad available in black only.  
Horn Panel Pad



68-69: Black, standard interior  
C8AZ-3629-A



68-69  
C8AZ-3629-BK



68-69  
C8AZ-3629-N



70-73: Black, standard  
D0ZZ-13915



71-73: Black, deluxe  
D1ZZ-13915

### HORN RING BUTTON

\*  Excellent concours reproduction. Diecast construction features acrylic plastic center emblem, chrome plated main assembly and painted recesses.  
Horn Ring Button



64: Standard, generator, concours, 3 spoke\*  
CSZZ-13A805-C



65-66: Standard, alternator, concours, 3 spoke\*  
CSZZ-13A805-B



65-67: Deluxe, for wood wheel, no emblem, 3 spoke  
C70Z-13A805-ER



67: Standard, no emblem, 3 spoke  
C7ZZ-13A805-A



68-69: Standard, no emblem, 2 spoke  
C9AZ-13A805-B

### HORN RING CENTER PAD



Soft padded urethane. Not painted but molded urethane so color will not

wear off. Features our chrome trim ring and center emblem.

#### Horn Ring Center Pad

67	Aqua*	C7ZZ-3623-AQ
67	Black*	C7ZZ-3623-BK
67	Blue*	C7ZZ-3623-BL
67	Ivy Gold*	C7ZZ-3623-IG
67	Parchment*	C7ZZ-3623-PR
67	Red*	C7ZZ-3623-RD
67	Saddle*	C7ZZ-3623-SA

### HORN RING CONTACT KIT



Exact reproduction horn ring contact components for the standard horn button.

#### Horn Ring Contact Kit

65-66	.....	CSZZ-13A821
67	.....	C7AZ-13A821
68-69	.....	C8AZ-13A821

### HORN RING RETAINER



Correct original design. Plastic injected nylon is more wear and crack resistant.

#### Horn Ring Retainer

64	Generator	C2DZ-13A809-A
65-66	Alternator	D1TZ-13A809-A

### HORN SWITCH

Fits deluxe or standard 2 spoke wheel.



#### Horn Switch

70-73	.....	D2AZ-13875
-------	-------	------------

### RIM BLOW HORN SWITCH

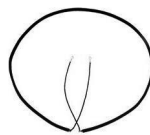

The switch that goes inside the rim of the steering wheel to actuate the horn.

#### Horn Switch, Rim Blow

69	.....	C9AZ-13A875-C
70-73	.....	D1AZ-13A875-A

### HORN SWITCH TRIM PLATE

Wood grain plate for deluxe 2 spoke wheel.



#### Horn Switch Trim Plate

71-73	Wood grain	.....	D1ZZ-13932
-------	------------	-------	------------

## STEERING WHEEL, GRANT

### GRANT HORN BUTTON



Optional button to customize your Grant steering wheel. Only fits 1170 wood

wheels.

#### Grant Horn Button

64-73	Horn button, fits 1170 and 1175*	..	5668
64-73	Grant 966 wheel*	.....	5847
64-73	Chrome*	.....	5875
65-73	Ford blue*	.....	5665

### GRANT HUB KIT

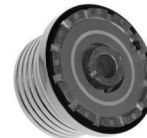

These kits are fully assembled for easy installation and are available in either a highly polished mirror finish or anodized in

deep, black luster finish. Fits 1170 and 1175 wheels only.

#### Grant Hub Kit

68-73	Black	.....	5249
68-73	Highly polished	.....	5249-1

### GRANT STEERING WHEEL



Aluminum frame aftermarket steering wheel with Mustang center emblem on horn center. 15 inch.

#### Grant Steering Wheel



64-73: Mahogany, 14" w/ polished alum spokes and rivets  
1175



64-73: Wood, 13 1/2" w/ brushed s/s spokes  
963



64-73: Wood, 15" w/ brushed s/s spokes\*  
966

Steering

**WE PROUDLY FEATURE AUTHENTIC MUSTANG REPRODUCTIONS FROM SCOTT DRAKE ENTERPRISES!**



195

**Grant Steering Wheel**



65-73: Mahogany, 14 1/2" w/ polished alum spokes  
1170



65-73: Black foam, 15" w/ brushed s/s spokes\*  
968

**GRANT STEERING WHEEL ADAPTER**

Mounting and contact adapter required for each Grant wheel.

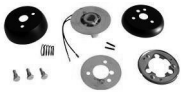

**Grant Steering Wheel Adapter**

64	.....	3285
65-67	.....	3294
68-73	.....	3249

**GRANT TILT COLUMN ADAPTER**

Special adapter required to run Grant" steering wheels on a Flaming River" tilt column. Replaces 3294 & 3249 adapters. Will

not work with Corso Feroce" steering wheels.

**Grant Tilt Column Adapter**

65-70	.....	CSZZ-3514-GMA
-------	-------	---------------

**STEERING WHEEL, CORSO FEROCCE**

**CORSO FEROCCE COBRA EMBLEM**



This fits the horn button to change center emblem to Cobra or Mustang.

**Corso Feroce Cobra Emblem**

65-73	Cobra, chrome plated w/ metal medalion <sup>s</sup>	.....	S1MS-3649-C
65-73	Running horse tribar emblem	.....	C7ZZ-65044A90-M

**CORSO FEROCCE COLUMN ADAPTER**



Hub to adapt the Corso Feroce steering wheels. Now with adjustable feature.

**Corso Feroce Column Adapter**

64-66	Billet	.....	S1MS-3511-P
67-73	Billet	.....	S7MS-3511-P

**CORSO FEROCCE HORN BUTTON**



Horn button for Corso Feroce steering wheel, has two wire connector.

**Corso Feroce Horn Button**

65-73	Double connector	.....	S1MS-3623-A
-------	------------------	-------	-------------

**CORSO FEROCCE STEERING WHEEL**

A beautiful wheel and the perfect choice for a Shelby look a like. These wheels are handcrafted with pride.

**Corso Feroce Steering Wheel**



65-73:	Genuine leather, 15 inch	.....	S1MS-3600-BK
--------	--------------------------	-------	--------------



**STEERING WHEELS**

**STEERING WHEEL HUB EMBLEM**

The most authentic and best looking emblems available.

**Emblem, Steering Wheel Hub**



67:	Running horse*	.....	C7Z-3649-A
-----	----------------	-------	------------



68:	Running horse*	.....	C8Z-3649-AR
-----	----------------	-------	-------------



68:	Shelby Cobra <sup>s</sup>	.....	S8MS-3649-A
-----	---------------------------	-------	-------------



69-70:	Shelby Cobra <sup>s</sup>	.....	C9MS-3649-A
--------	---------------------------	-------	-------------



69-73:	For use on 2-spoke wheel	.....	C9ZZ-3649-S
--------	--------------------------	-------	-------------

**Emblem, Steering Wheel Hub**



1969	Deluxe Steering Wheel Emblem	.....	C9ZZ-3649-B
------	------------------------------	-------	-------------



70-73	Deluxe Steering Wheel Emblem	.....	DOZZ-3649
-------	------------------------------	-------	-----------

**STEERING WHEEL HUB TRIM**



This is the chrome trim ring that goes on the steering wheel hub. 4 3/8" diameter. Installation note: warm up foam hub with

hot air, apply solution of dish washing soap & water, then press firmly.

**Hub Trim, Steering Wheel**

67	.....	C7ZZ-3656-A
----	-------	-------------

**STEERING WHEEL HUB TRIM & EMBLEM**



Great kit for complete steering wheel restoration.

**Hub Trim & Emblem, Steering Wheel**

67	*	.....	C7ZZ-3649/56-K
----	---	-------	----------------

**STANDARD STEERING WHEELS**



Molded in hard plastic, wheel feature nice details, a new wheels really brings the interior together.

**Steering Wheel, Standard**

64	Black, generator	.....	C4ZZ-3600-BK
64	Blue, generator	.....	C4ZZ-3600-BL
64	Palamino, generator	.....	C4ZZ-3600-PA
64	Red, generator	.....	C4ZZ-3600-RD
64	White, generator	.....	C4ZZ-3600-WT
65	Blue	.....	C5ZZ-3600-BL
65	Bright red	.....	C5ZZ-3600-BR
65-66	Black	.....	C5ZZ-3600-BK
65-66	Palamino and parchment	.....	C5ZZ-3600-PA
65-66	White	.....	C5ZZ-3600-WT
66	Aqua	.....	C6ZZ-3600-AQ
66	Dark red	.....	C6ZZ-3600-DR
66	Light blue	.....	C6ZZ-3600-LB
66	Parchment	.....	C6ZZ-3600-PR
67	Black	.....	C7ZZ-3600-BK
67	Blue	.....	C7ZZ-3600-BL
67	Dark red	.....	C7ZZ-3600-DR
67	Ivy Gold	.....	C7ZZ-3600-IG

**Steering Wheel, Standard**

- 67 Parchment .....C7ZZ-3600-PR
- 68-69 Black .....C8ZZ-3600-BK
- 68-69 Blue .....C8ZZ-3600-BL
- 68-69 Dark red .....C8ZZ-3600-DR
- 68-69 Ivy Gold ..... C8ZZ-3600-IG

**WOOD STEERING WHEEL**

**Steering Wheel, Wood**



64-73: GM spline, for use with Flaming River tilt column S1MS-3600-WGK

**DELUXE STEERING WHEEL ASSEMBLY**



Reproduction of Pony interior simulated wood wheel. Includes horn ring, contact plates and hardware. This wheel was also

optional on standard interior cars. Horn center cap sold separately.

**Steering Wheel Assembly, Deluxe**

- 65-66 Woodgrain, assembly .... C5ZZ-3600-NK
- 65-66 Woodgrain, wheel only, for pony interior ..... C5ZZ-3600-N
- 67 Woodgrain, assembly ....C70Z-3600-NK

**STEERING WHEEL CENTER**



Deluxe wheel only. Pressure die cast with quality chrome plating. Includes lens,

rim, spring steel snap ring.

**Steering Wheel Center**

- 65-66 Concours\* ..... C5ZZ-3623-A
- 65-66 Economy\* .....C5ZZ-3623-AR
- 66 Shelby, U.S.A.® ..... S2MS-3623-A

**STEERING WHEEL COLLAR**



Mounts on bottom of original deluxe wheel. Die cast construction like original. Concours plating.

**Steering Wheel Collar**

- 65-66 ..... C5ZZ-3491-A
- 67 .....C70Z-3491-A

**UPPER STEERING WHEEL COLLAR**



All the detail is contained in the finally available item.

**Steering Wheel Collar, Upper**

- 67 Deluxe .....C70Z-3656-A

**STEERING WHEEL HORN CONTACT PLATE**



Deluxe Wood Wheel Horn Contact Plate.

**Steering Wheel Horn Contact Plate**

- 65-66 ..... C5ZZ-13A808/9

**STEERING WHEEL INSULATOR HARDWARE KIT**



**Steering Wheel Insulator Hardware Kit**

- 65-67 Deluxe ..... C5ZZ-13A890/1MK

**STEERING WHEEL INSULATOR KIT**



Plastic injection, exact copies of these hard to find originals. Fits on both horn contact rings. Insulates

mounting screws from contact rings. Pony interiors and deluxe wood wheels only.

**Steering Wheel Insulator Kit**

- 65-67 .....C5ZZ-13A890/1-A

**STEERING WHEEL NUT**



This really is the nut behind the steering wheel.

**Steering Wheel Nut**

- 64-67 Nut..... 350983-5
- 64-67 Steering Column Spring ..... C3DZ-3520-A
- 64-67 Column Bushing..... B1AZ-3518-A

**TIE RODS**

**INNER TIE ROD**



Premium U.S.A. brands like Moog, TRW, or Federal Mogul. Very good quality at a fair price.

**Tie Rod, Inner**

- 64-66 6 cylinder, manual steering, right or left hand ..... C3DZ-3A131-AR
- 64-66 6 cylinder, power steering, right hand .... C4DZ-3A130-D
- 64-66 6 cylinder, power steering, left hand ..... C4DZ-3A131-C
- 64-66 V8, power steering, left hand ..... C5ZZ-3A131-CR
- 64-66 V8, manual steering right or left hand, power steering right hand ..... C5ZZ-3A131-DR
- 67-69 6 and 8 cylinder, right or left hand ..... C7ZZ-3A131-AR
- 70 6 and 8 cylinder, right or left hand ..... D0ZZ-3A131-AR
- 71-73 6 and 8 cylinder, right or left hand ..... D1ZZ-3A131-AR

**OUTER TIE ROD**



Premium U.S.A. brands like Moog, TRW, or Federal Mogul. Very good quality at a fair price.

**Tie Rod, Outer**

- 64-66 6 cylinder, manual steering, right or left hand ..... C3DZ-3A130-AR
- 64-66 6 cylinder, power steering, right hand .... C4DZ-3A130-C
- 64-66 6 cylinder, power steering, left hand ..... C4DZ-3A131-D
- 64-66 V8, power steering, left hand ..... C5ZZ-3A130-CR
- 64-66 V8, manual steering right or left hand, power steering right hand ..... C5ZZ-3A130-DR
- 64-66 V8, power steering, left hand ..... C5ZZ-3A130-SPEC
- 67-69 6 and 8 cylinder, right or left hand ..... C7ZZ-3A130-AR
- 70-73 6 and 8 cylinder, right or left hand ..... D1ZZ-3A130-AR

Steering

**WE PROUDLY FEATURE AUTHENTIC MUSTANG REPRODUCTIONS FROM SCOTT DRAKE ENTERPRISES!**



### INNER TIE ROD (IMPORTED)



These quality inner tie rods are imported, but have been designed and built to meet or exceed OEM specifications.

#### Tie Rod (Imported), Inner

- 64-66 6 cylinder, manual steering, right or left hand ..... C3DZ-3A131-ARI
- 64-66 V8, power steering, left hand ..... CSZZ-3A131-CRI
- 64-66 V8, manual steering right or left hand, power steering right hand ..... CSZZ-3A131-DRI
- 67-69 6 and 8 cylinder, right or left hand ..... C7ZZ-3A131-ARI
- 70 6 and 8 cylinder, right or left hand ..... DOZZ-3A131-ARI

### OUTER TIE ROD (IMPORTED)



These quality outer tie rods are imported, but have been designed and built to meet or exceed OEM specifications.

#### Tie Rod (Imported), Outer

- 64-66 6 cylinder, manual steering, right or left hand ..... C3DZ-3A130-ARI
- 64-66 V8, power steering, left hand ..... CSZZ-3A130-CRI
- 64-66 V8, manual steering right or left hand, power steering right hand ..... CSZZ-3A130-DRI
- 67-69 6 and 8 cylinder, right or left hand ..... C7ZZ-3A130-ARI
- 70-73 6 and 8 cylinder, right or left hand ..... D1ZZ-3A130-ARI

### TIE ROD ADJUSTING SLEEVE

Name brand quality.



#### Tie Rod Adjusting Sleeve

- 64-66 V8, power steering, left hand Only ..... C2VY-3310-AR
- 64-74 64-66: V8 / 67-73: 6 and 8 cylinder, power steering, left or right hand ..... C2AA-3310-AR
- 64-73 64-66: V8 / 67-73: 6 and 8 cylinder, power steering, left or right hand, Import ..... C2AA-3310-ARI
- 64-66 6 cylinder, power steering CSZZ-3310-AR
- 64-66 6 cyl, manual ..... C3DZ-3310-ARI

### TIE ROD END DUST SEAL



These aftermarket dust seals are more durable than the original rubber units, and will not blow out under grease pressure. Black

only.

#### Tie Rod End Dust Seal

- 64-67 Polyurethane ..... 9-13103
- 67-73 Polyurethane ..... 9-13101

## SUSPENSION

### COIL SPRINGS

#### GT COIL SPRING



These springs were original equipment on 1965 - 1966 GT Mustangs. Firmer than stock but offer a softer ride than our 600

pound racing springs. Ideal for anyone looking for improved handling without sacrificing ride comfort. Made in the U.S.A. exclusively for Scott Drake. Features black powder coating.

#### Coil Spring, GT

- 65-66 Original GT ..... CSZZ-5310-E

#### PERFORMANCE COIL SPRING



These springs are custom wound for the performance oriented customer. They feature 600-pound/inch rating and will lower the car

approximately one inch from original stock height. Made in the U.S.A. exclusively for Scott Drake. Features black powder coating.

#### Coil Spring, Performance

- 64-66 High performance, black. .. CSZZ-5310-P
- 67-73 High performance ..... C7ZZ-5310-P

#### PROGRESSIVE RATE COIL SPRING



These springs allow your Classic Mustang to take advantage of the latest suspension technology and perform more like a

modern sports car. They really do give you the best of both worlds. A fairly stock smooth ride during normal driving, but as the springs compress under load (primarily during braking and cornering) they progressively become firmer very quickly to offer the handling characteristics similar to our 600 pound performance springs, but without sacrificing ride comfort. These progressive rate

springs are suitable for long pleasant family road trips as well as a variety of autocross and race courses. These are a little more money, but well worth it if you are looking for the best money can buy. Made exclusively for us in the U.S.A. by a premier OEM supplier (for strictly race car applications we still recommend our Performance Springs). Our Progressive Rate Coil Springs feature: Hot wind from SAE5160H, oil quench, temper, water quench, shot peen, preset, 100% load test, ground flat and black powder coating. These springs will sit your vehicle lower than our Stock Coil Springs, actual drop will vary with overall car weight. **Note: 1970 351C cars can choose either Small Block or Big Block springs based on car's options. Cars with heavy factory cast-iron intake, PS and AC might be better suited with big block version but can chose Small Block version as well. On all other 351C applications Small Block version is recommended as car may sit higher than preferred if there is not enough weight over the springs.**

#### Coil Spring, Progressive Rate

- 64-66 V8 400-550 # ..... CSZZ-5310-PR
- 67-70 Small Block 289, 302, 351W 400-525 # ... C7ZZ-5310-SB-PR
- 67-70 Big Block 67-70: 390, 428, 460-600# ..... C7ZZ-5310-BB-PR
- 71-73 Big Block 71-73: 351C 460-600# ..... C7ZZ-5310-BB-PR

#### STOCK COIL SPRING



Replace your old worn out springs with these quality aftermarket replacements, made in the U.S.A. Features black powder coating.

#### Coil Spring, Stock

- 64-66 6 cylinder ..... CSZZ-5310-A
- 64-66 V8 w/ AC ..... CSZZ-5310-B
- 64-66 V8 w/out AC ..... CSZZ-5310-C
- 67-70 6 cylinder ..... C7ZZ-5310-A
- 67-70 Big block w/ AC ..... C7ZZ-5310-C
- 67-70 390 w/out AC, or 351C w/ AC & PS ..... C7ZZ-5310-D
- 67-73 Small Block ..... C7ZZ-5310-B

#### COIL SPRING INSULATOR



#### Coil Spring Insulator

- 64-73 Rubber - original 1/8" thick ..... C4DZ-5415-AR
- 64-73 Black polyurethane - 3/8" thick ..... C4DZ-5415-UR

**Coil Spring Insulator**

64-73 Black polyurethane, 1" thick .....  
C4DZ-5415-URT

**COIL SPRING PERCH**



Features quality stamped steel construction, bushings, nuts, anti-squeak coil protector pads. Excellent quality

OEM design.

**Coil Spring Perch**

64-73 Individually packaged ..... C4DZ-3388-RI

64-73 Bulk, must purchase in multiples of 20 ..  
C4DZ-3388-BULK

**COIL SPRING PERCH BUSHING**



This critical bushing takes a lot of abuse from the extra weight and pressure of the coil spring. High-performance

polyurethane replacement bushings.

**Coil Spring Perch Bushing**

64-73 ..... C4DZ-3388-PB

**CONTROL ARMS**

**UPPER BALL JOINT KIT**



These are the best available. Includes ball joint, rubber boot and mounting hardware.

**Ball Joint Kit, Upper**

64-73 4 bolt, import ..... C70Z-3049-A

64-73 4 bolt, U.S.A. .... C70Z-3049-AR

64-73 3 bolt, import ..... D00Z-3049-A

64-73 3 bolt, U.S.A. .... D00Z-3049-AR

**LOWER CONTROL ARM**

These lower control arms are authentic reproductions. Comes complete with balljoint, pressed in bushing, grease seal, zerk fitting, washer, nut and cotter key.

**Control Arm, Lower**



64-66: Black, gray w/ jacking tabs  
C4DZ-3078-A



64-66: Black, U.S.A. made  
C4DZ-3078-AR

**Control Arm, Lower**



67: Black, gray w/ jacking tabs  
C70Z-3078-A



67: Black, U.S.A. made  
C70Z-3078-AR



68-73: Black, gray w/out jacking tabs



68-73: Black w/out jacking tabs



68-73: Black, U.S.A. made



68-69: Black/gray, w/ jacking tabs

**UPPER CONTROL ARM**

These upper control arms are the finest reproductions available. Not rebuilt, all new. Riveted ball joint as original. They come complete with shaft, bushings, ball joint, nut with cotter key, 90 degree zerks, washers and locking nuts.

**Control Arm, Upper**



64-66: Black, gray  
C4DZ-3082-RI



67-73: Black, silver  
C7DZ-3082-A



67-73: Black  
C7DZ-3082-RI

**LOWER CONTROL ARM BOLTS**

Concours correct lower control arm bolts. 67-73 adjustable version pictured.

**Control Arm Bolts, Lower**



64-66  
373142-S



67-73  
C60A-3B236-K

**LOWER CONTROL ARM BUSHING**



All bushings are graphite impregnated polyurethane. Only fits U.S.A. made control arms.

**Control Arm Bushing, Lower**

64-66 ..... 4-3101

67-73 17/16 inch outside diameter, black .....  
4-3102

67-73 19/16 inch outside diameter, black .....  
4-3106

**UPPER CONTROL ARM SHAFT KIT**



Complete kit with shaft, bushings, grease seals, bolts, and zerk fittings. Fits original Ford control arm.

**Control Arm Shaft Kit, Upper**

64-66 ..... C3DZ-3047-AR

67-73 ..... C60Z-3047-AR

**ZERK FITTING**

Our special extended zerk grease fittings are designed so that cutting shock towers for access will not be necessary. Plated to prevent corrosion.

**Zerk Fitting**



64-73: 90 degree  
374714-S



64-73: Extended version w/ tool  
374714-SK

**WE PROUDLY FEATURE AUTHENTIC MUSTANG REPRODUCTIONS FROM SCOTT DRAKE ENTERPRISES!**





## FRAME

### SUB FRAME CONNECTOR



These connectors join front and rear frame rails to make the uni-body much more rigid. This greatly improves handling by reducing

body flex allowing the suspension to react quicker. Black powder coated.

#### Sub Frame Connector

64-70 Coupe and Fastback ..... C5ZZ-5479-A

## LEAF SPRINGS AND SHACKLES

### AXLE U BOLT



Made by Drake, these Axle U Bolts are now concours correct! No longer a generic U-Bolt, these feature proper flattened area

for a more secure fitment to axle housing. Also includes concours correct flanged locking nuts. All of this for almost the same affordable price as the old, generic versions.

#### Axle U Bolt

64-66 6 or 8 cylinder ..... C5ZZ-5705-K

67 6 or 8 cylinder, except 428 . C7ZZ-5705-K

68-69 428 not concours ..... C8ZZ-5705-K

68-73 6-cylinder, V8 except 428... C8ZZ-5705-A

### ORIGINAL 4 LEAF SPRING

These premium springs are made using high-quality spring steel to assure a smooth, stable ride that will last for years. Features OEM style clamps, correct "hot cupped" ends, anti-squeak pads, front eye bushing installed and OEM 4 leaf design. They will also help lift that sagging rear end. Ford originally listed more than 24 different part numbers for the Mustang between 1964-73. The parts varied only slightly, depending on body style, options, engine size, handling options, and transmission. Scott Drake has chosen 2 different springs as the most universal and one of these should meet most customers' needs. Choose from either C5ZZ-5560 which has a slightly stiffer rate and higher arch. But it may raise your car higher than it's original stock height depending on total weight of the vehicle. This is especially true on early model 6-cylinder cars. Still this is the more popular

spring as most customers do not like the traditional slightly lower in the rear look that Mustangs are infamous for. But if an original lower ride height is more what you are after we also offer a Light Duty version under part number C5ZZ-5560-S. Although we make absolutely no guarantees about actual ride height on your particular car, as there are many variables to contend with, please find the below comparison we did between the two springs to give you an approximate idea of ride heights you can expect. The test was done on a 67-68 coupe and measured at the top center of the rear wheel arch. (Note: 64-66, 69-70 and 71-73 wheel arches are not exactly the same so their measurement would vary. The test car had 215-70-14 tires on it. On the test car our C5ZZ-5560 measured 26.75" and the C5ZZ-5560-S measured 26". Once again, these measurements will vary from car to car depending on tire size, tire pressure, full or empty tank, and overall weight; but you can expect your car to sit about 3/4" higher with C5ZZ-5560 over C5ZZ-5560-S.

#### Leaf Spring



64-68: 4 leaf, light duty, stock height  
C5ZZ-5560-S



64-73: 4 leaf, standard, stock height  
C5ZZ-5560

## PERFORMANCE REAR LEAF SPRINGS

We offer a large selection of performance leaf springs in both 4.5 and 5 leaf versions to suit any driver, and any application on or off the track and at any ride height. These premium springs are made using high-quality spring steel to assure a smooth stable ride that will last for years. Painted detail gray to look as good as they perform. 1" and 2" lowering versions refer to drops compared to standard eye heavy-duty 5 leafs which may sit slightly higher than original depending on year and original options your car was equipped with.

#### Leaf Springs.

#### Leaf Spring



64-73: 4.5 leaf, mid eye, lowers 1"  
C5ZZ-5560-4ME



64-73: 5 leaf, standard eye, heavy duty  
C5ZZ-5560-HD

#### Leaf Spring



64-73: 5 leaf, mid eye, lowers 1"  
C5ZZ-5560-HPME



64-73: 5 leaf, Reverse eye, lowers 2"  
C5ZZ-5560-RE

### LEAF SPRING BUSHING KIT



Includes eye bushings and shackle bushings.

#### Leaf Spring Bushing Kit

64-73 .....C5ZZ-5630/5781B

### LEAF SPRING EYE BOLT



Grade 8 Hardened bolt kit includes two bolts and two nuts.

#### Leaf Spring Eye Bolt

64-67 ..... C5ZZ-5781-A

68-73 ..... C7ZZ-5781-A

### LEAF SPRING EYE BUSHING



#### Leaf Spring Eye Bushing

64-73 ..... C5ZZ-5630-R

### LEAF SPRING PLATE



This is the plate that secures the rear spring U-bolts to the differential, it also is the mounting point for the rear shock

#### absorber.

#### Leaf Spring Plate

64-66 Right hand ..... C5ZZ-5798-R

64-66 Left hand .....C5ZZ-5799-L

67-70 Right hand, except Boss & CJ .....

C6DZ-5796-A

67-70 Left hand, except Boss & CJ C6DZ-5796-B

**POLYURETHANE LEAF SPRING SHACKLE BUSHING**



A set of eight polyurethane shackle bushings. These have a 1/2 inch bore.

**Leaf Spring Shackle Bushing, Polyurethane**  
66-73 1/2 inch hole, black polyurethane .....  
C6ZZ-5781-BP

**RUBBER LEAF SPRING SHACKLE BUSHING**



Sets include 8 rubber, leaf spring shackle bushings.

**Leaf Spring Shackle Bushing, Rubber**  
64-65 9/16 inch hole, rubber .....C5ZZ-5781-BR  
66-73 1/2 inch hole, rubber .....C6ZZ-5781-BR

**REAR END LOWERING KIT**



Don't heat your springs or remove leaves. Now its easier and safer to lower the rear end. This kit includes cast aluminum lowering

blocks, U bolts with nylock nuts. Not a universal kit but specially designed for the Mustang.  
**Rear End Lowering Kit**  
64-66 1 inch drop ..... C5ZZ-5705-LK1  
66-70 1 inch drop ..... C7ZZ-5705-LK1

**ADJUSTABLE SHACKLE KIT**



These extreme shackles feature heavy duty 1/4" thick plates and polyurethane bushings with special grooves which allow

lubrication. Adjustments allow a 3/8" inch lift from stock position.  
**Shackle Kit, Adjustable**  
64-73 Adjustable ..... C5ZZ-5776-HD

**STAINLESS STEEL SHACKLE KIT**



Beautiful parts with details like originals. Available in a variety of styles & designs. 1" longer version will raise rear of car 1/2"

higher if rear springs are in new condition. GT version allows more exhaust clearance, plus

are easier to install.

**Shackle Kit, Stainless Steel**  
64-73 9/16 inch rods, dual exhaust, polished stainless steel .....C5ZZ-5776-GTSS  
64-73 Dual exhaust, 1 inch longer, polished stainless steel .....C5ZZ-5776-GTSSL

**SHACKLE KIT WITH DETAIL GRAY FINISH**

Beautiful parts with details like originals. Available in a variety of styles & designs. 1" longer version will raise rear of car 1/2" higher if rear springs are in new condition. GT version was originally used on 65-66, but will work on all cars as it allows more exhaust clearance, plus are easier to install.

**Shackle Kit with Detail Gray Finish**



64-65: 9/16 inch rods, dual exhaust, gray  
C5ZZ-5776-GT .....



64-65: 9/16 inch rods, standard, gray  
C5ZZ-5776-K



64-73: Dual exhaust, 1 inch longer, gray  
C5ZZ-5776-GTL



66-73: 1/2 inch rods, dual exhaust, gray  
C6ZZ-5776-GT



66-73: 1/2 inch rods, standard, gray  
C6ZZ-5776-K

**MONTE CARLO BARS, EXPORT & TOWER BRACES**

**COWL BRACE TO COWL HARDWARE**

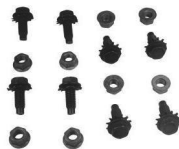

These are their real thing, not just generic nuts and bolts.

**Cowl Brace To Cowl Hardware**  
64-68 .....C5ZB-260

**AUTHENTIC EXPORT BRACE**



Correct for all authentic Shelby's and Fords built for overseas export. Same quality as our extra-strength export braces. These

feature equal mounting hole spacing where brace attaches to firewall.

**Export Brace, Authentic**  
65-66 Shelby, chrome .....S1MS-16A052-C  
65-66 Shelby, black .....S1MS-16A052-E

**EXTRA STRENGTH EXPORT BRACE**

We made these export braces from the Ford print. Heavier than other reproductions. Exact details with correct deep draw stamping. Available in 3 finishes to compliment any engine compartment. Our export braces fit without drilling, prying and jumping on the front end. Greatly reduces twisting of the chassis. Also strengthens the front end and helps reduce shock tower fatigue and cracking.

**Export Brace, Extra Strength**



64-70: Chrome  
CSZZ-16A052-C



64-70: Black  
CSZZ-16A052-E



64-70: Satin  
CSZZ-16A052-S

**EXPORT BRACE MOUNTING PLATE**

Reinforcement plate that mounts on cowl.  
**Export Brace Mounting Plate**



64-66  
CSZZ-16A052-MP



65-66: Shelby  
S1MS-16A052-MP



67-70  
C7ZZ-16A052-MP

Suspension

**WE PROUDLY FEATURE AUTHENTIC MUSTANG REPRODUCTIONS FROM SCOTT DRAKE ENTERPRISES!**



201

## MONTE CARLO BAR



This extra support also helps prevent shock tower stress cracks. Copied from the original design, our bars feature a new

thicker diameter tube and improved fender brackets. We have also stamped square holes in the top of each fender bracket to allow for the use of lower profile carriage bolts.

### Monte Carlo Bar

64-66	Straight, black	.....	CSZZ-16A052-ARB
64-66	Straight, chrome	.....	CSZZ-16A052-ARC
64-66	Straight, satin	.....	CSZZ-16A052-ARM
64-66	Straight, stainless steel	.....	CSZZ-16A052-ARS
64-66	Curved, black	.....	CSZZ-16A052-BRB
64-66	Curved, chrome	.....	CSZZ-16A052-BRC
64-66	Curved, satin	.....	CSZZ-16A052-BRM
64-66	Curved, stainless steel	.....	CSZZ-16A052-BRS
67-68	Straight, black	.....	C7ZZ-16A052-ARB
67-68	Straight, chrome	.....	C7ZZ-16A052-ARC
67-68	Straight, satin	.....	C7ZZ-16A052-ARM
67-68	Straight, stainless steel	.....	C7ZZ-16A052-ARS
67-68	Curved, black	.....	C7ZZ-16A052-BRB
67-68	Curved, chrome	.....	C7ZZ-16A052-BRC
69-70	Straight, black	.....	C9ZZ-16A052-ARB
69-70	Straight, chrome	.....	C9ZZ-16A052-ARC
69-70	Curved, black	.....	C9ZZ-16A052-BRB
69-70	Curved, chrome	.....	C9ZZ-16A052-BRC
71-73	Straight, black	.....	D1ZZ-16A052-A

## RACE MONTE CARLO BAR



The monte carlo bars with "J" in the part number, are equipped with Heim joints for smoother operation.

### Monte Carlo Bar, Race

65-66	Curved, black	.....	CSZZ-16A052-BJB
65-66	Curved, stainless steel	.....	CSZZ-16A052-BJS
67-68	Curved, black	.....	C7ZZ-16A052-BJB
67-68	Curved, stainless steel	.....	C7ZZ-16A052-BJS

## SHOCK TOWER BRACE



Very nice reproductions. Stamped and formed steel, ready for paint or chrome finish.

### Shock Tower Brace

67-68	.....	C7ZZ-16A052-PR
69-70	.....	C9ZZ-16A052-PR
71-73	.....	D1ZZ-16A052/3

## SHOCKS AND STRUTS

### SHOCK



This KYB gas shock improves handling without sacrificing ride comfort. A very good choice for the daily driver wanting a

smooth ride with the response of a gas shock.

#### Shock, Front

64-73	Rear	.....	KYB343219
65-70	Front	.....	KYB343146
71-73	Front	.....	KYB343156

### GAS-A-JUST SHOCK



KYB Gas-a-just shocks are America's best selling performance gas shock. It's monotube design features a higher gas

pressure which helps to hold the tire to road surface during severe driving conditions. N2 gas helps eliminate shock fading due to aeration and foaming. This shock is the perfect choice for the performance oriented Mustang. Shocks are painted silver.

#### Shock, Gas-A-Just

64-70	Gas-A-Just, Front	.....	KG-4517
64-73	Gas-A-Just, Rear	.....	KG-5517
71-73	Gas-A-Just, Front	.....	KG-4504

### HIGH PERFORMANCE SHOCK



Drake Automotive Group is proud to officially re-introduce our own version of a performance oriented High

Pressure Gas Shock for the Classic Mustang. After over 2 years of Sales, Road Testing and customer feedback we have reduced the gas pressure by 10% in the front and 15% in the rear to better accommodate the majority of performance oriented drivers and also help ease installation. These are equal in performance to other Name Brand High Pressure Gas Shocks at a significantly Lower Price. Best suited for Drivers looking for Firm Ride with a solid controlled "Feel of the Road".

#### Shock, Rear

64-70	Performance, Drake Automotive	.....	CSZZ-18124-HP
64-73	Performance, Drake Automotive	.....	CSZZ-18125-HP

## STRUT ROD BRACKET



High quality steel, painted black. Welding required for install.

### Strut Rod Bracket

64-66	Left hand	.....	CSZZ-6503487-L
64-66	Right hand	.....	CSZZ-6503487-R
67-70	Left hand, lower	.....	C7ZZ-6503487-L
67-70	Right hand, lower	.....	C7ZZ-6503487-R

## STRUT ROD BUSHING

Each kit comes neatly packaged.

### Strut Rod Bushing



64-66: OEM, rubber, Set of 4  
Concours correct bushings  
C4DZ-3A187-A



64-66: OEM, rubber, 10 piece kit  
Concours correct bushings & washers, not generic  
C4DZ-3A187-AR



67-73: OEM, rubber, set of 4  
Concours correct bushings  
C60Z-3A187-A



67-73: OEM, rubber, 10 piece kit  
Concours correct bushings & washers, not generic  
C60Z-3A187-AR

## STRUT RODS

Forged heavy-duty construction. If your car has been in an accident, check this part for damage.



### Strut Rods

64-66	.....	CSZZ-3468-B
67	LH or RH, 6 or 8 cylinder	.....C70Z-3468-A
68-73	Right hand, with nut	.....C9ZZ-3468-C
68-73	Left hand, with nut	.....C9ZZ-3468-D
68-73	Nuts only	.....380460-S

## SUSPENSION BUMPERS

### AXLE BUMPER



Injected molded rubber. Protects floor, and stops 3rd member from contacting floor.

### Axle Bumper

65-70	Outer rear, mounts on frame	.C3DZ-4730
-------	-----------------------------	------------

### Axle Bumper

65-70 Center rear, mounts above 3rd member .  
CSZZ-4730

### **POLYURETHANE FRONT SUSPENSION BUMPER**



Stops suspension travel damage.

Front Suspension Bumper, Polyurethane  
64-73 Polyurethane .....C3DZ-3020-P

### **RUBBER FRONT SUSPENSION BUMPER**



Stops suspension travel damage.

Front Suspension Bumper, Rubber  
65-66 Rubber .....C3DZ-3020-A  
67-69 Rubber .....C60Z-3020-A  
69-73 Rubber .....C90Z-3020

## SWAY BARS

### **FRONT SWAY BAR**



Front sway bars minimize body lean when cornering.

#### Sway Bar, Front

67-70 1 inch, small block ..... C7ZZ-5482-A  
67-70 1 1/8 inch, small block ..... C7ZZ-5482-B  
67-70 1 inch, big block, clears oil filter .....  
C7ZZ-5482-BB  
71-73 1 inch ..... D1ZZ-5482-A  
71-73 1 1/8 inch ..... D1ZZ-5482-B  
64-66 1 inch ..... S1MS-5482-A  
64-66 1 1/8 inch ..... S1MS-5482-B

### **REAR SWAY BAR**

Rear sway bars minimize body lean when cornering.  
Sway Bar, Rear



64-73: 3/4" adjustable  
CSZZ-5486-ADJ



64-66: 3/4"  
CSZZ-5486

### Sway Bar, Rear



67-70: 3/4"  
C7ZZ-5486

### **SWAY BAR BUSHING**



Our black rubber bushings are exact copies of the original. Features correct shoulder and split for easy installation. Some

sway bar brackets may not accommodate the raised anti-slip shoulder, trimming with razor blade may be required.

#### Sway Bar Bushing

64-66 5/8 inch .....C4DZ-5493-B  
64-73 11/16 inch .....C60Z-5493-A  
64-73 3/4 inch .....C60Z-5493-B  
64-73 7/8 inch .....C60Z-5493-E  
64-73 15/16 inch .....C60Z-5493-I  
64-73 1 inch .....C60Z-5493-J  
65-66 7/8 inch, GT, no flanges .... CSZZ-5493-A

### **POLYURETHANE SWAY BAR BUSHING KIT**



Our special polyurethane bushings reduce deflection at the bar mounts to quicken the action of stock or aftermarket

sway bars. Available in a wide range of sizes, with matching mount brackets. Includes lubrication groove to prevent squeaking.

#### Sway Bar Bushing Kit

64-73 Black, 5/8 inch ..... CSZZ-5486-A  
64-73 Black, 11/16 inch ..... CSZZ-5486-B  
64-73 Black, 3/4 inch ..... CSZZ-5486-H  
64-73 Black, 13/16 inch .....CSZZ-5486-C  
64-73 Black, 7/8 inch ..... CSZZ-5486-D  
64-73 Black, 15/16 inch .....CSZZ-5486-E  
64-73 Black, 1 inch .....CSZZ-5486-F  
64-73 Red, 1 1/8 inch .....614D-5493-K  
64-73 Black, 1 1/8 inch ..... CSZZ-5486-G

### **ADJUSTABLE SWAY BAR END LINK**



This allows quick secure adjustments of sway bar. Teflon lined rodbearing also makes steering response instantaneous.

#### Sway Bar End Link, Adjustable

65-73 ..... CSZZ-5A486-ADJ

### **POLYURETHANE SWAY BAR END LINK KIT**



Our End Link kits include high performance polyurethane bushings. Use polyurethane bushings

to eliminate deflection losses at the ends of the sway bar. Kit includes 2 links.

#### Sway Bar End Link Kit, Polyurethane

64-66 Black polyurethane ..... CSZZ-5A486-K  
67-73 Black polyurethane ..... C7ZZ-5A486-K

### **RUBBER SWAY BAR END LINK KIT**



Our End Link kits include rubber bushings and plated hardware. Kit includes 2 links.

#### Sway Bar End Link Kit, Rubber

64-67 Rubber ..... CODZ-5A486-BR  
68-73 Rubber ..... C20Z-5A486-AR

## TRACTION BARS

### **UNDER RIDE TRACTION BAR**



They greatly reduce wheel hop and improve acceleration. They also keep the rear springs from "unwrapping" during

decelerating. Traction Master was the original supplier to Shelby.

#### Traction Bar, Under Ride

64-66 Traction Master .....TM-1068  
64-66 Generic .....TM-1068-R  
67-70 Traction Master .....TM-1069  
67-70 Generic .....TM-1069-R

## TRANSMISSION & DRIVETRAIN

## CLUTCH COMPONENTS

### **CLUTCH CABLE KIT**



Kits include adjustable bracket that bolts to stock clutch pedal, firewall support plate and a "tool free" cable adjuster. Compatible

with most brake boosters and work on T5, Tremec and T56 applications with late model

Transmission

**WE PROUDLY FEATURE AUTHENTIC MUSTANG  
REPRODUCTIONS FROM SCOTT DRAKE ENTERPRISES!**



203

bell housings.

**Clutch Cable Kit**

- 64-66 T-5 and Tremec ..... CSZZ-CCK
- 67-68 T-5 and Tremec ..... CZZZ-CCK
- 69-70 T-5 and Tremec ..... C9ZZ-CCK
- 71-73 T-5 and Tremec ..... D1ZZ-CCK

**CLUTCH CABLE**



**Clutch Cable**

- 64-70 Cable only ..... CSZZ-CCK-CABLE

**CLUTCH FORK**

The fork that houses the clutch release bearing. C50Z-7515-B requires C6AZ-7562-A.



**Clutch Fork**

- 65-68 289, 3 or 4 speed transmission, 9 1/4 inches ..... C50Z-7515-B
- 68-69 Small block, clip on ..... C80Z-7515-A
- 68-69 390 ..... C80Z-7515-B
- 68-69 428 ..... C80Z-7515-D

**CLUTCH ANTI-RATTLE SPRING**

Anti-rattle spring for the clutch lever.



**Clutch Anti-Rattle Spring**

- 65-68 ..... C6AZ-7562-A

**CLUTCH FORK PIVOT**

Heavy duty, Hardware included.



**Clutch Fork Pivot**

- 65-67 Small block, 289 ..... B9AZ-7522-B
- 68-72 Small block, 6 cylinder ..... C8AZ-7522-B

**6-CYLINDER, COMPLETE CLUTCH**

**KIT**

Previously nearly impossible to find we are pleased to announce these New 6cyl Complete Clutch Kits both in the early

8.5" Versions and later 9" Versions. These are made by a well respected clutch manufacturer



to provide a trouble free installation and long service life.

**Clutch Kit, 6-cylinder, Complete**

- 64-66 1964-early 66, 6-cyl, 8.5" clutch ..... C4DZ-7563-KIT
- 66-73 Late 66-73, 6-cyl, 9" Clutch ..... C6DZ-7563-KIT

**STOCK CLUTCH SETS**

Quality clutch sets. Includes clutch disc, pressure plate, throw out bearing & alignment tool.



**Clutch Sets, Stock**

- 64-73 V8, 10 inch ..... CSZZ-7563-K
- 67-73 351, 390, 11 inch ..... CZZZ-7563-K

**PERFORMANCE CLUTCH SETS**

Excellent upgrade clutch set up. A must for towing or high performance applications. All new components include



pressure plate, clutch disc, throwout bearing and alignment tool.

**Clutch Sets**

- 64-73 High performance, 10 1/2 inch, HDX ..... CSZZ-7563-ZHPK
- 64-73 High performance, 10 inch ..... CSZZ-7563-ZK
- 67-73 High performance, 11 inch, except 1 3/8 inch input ..... CZZZ-7563-ZK

**CLUTCH LEVER DUST BOOT**

Molded EPDM-neoprene blend. Resist damage from grease and dirt.



**Clutch Lever Dust Boot**

- 65 6 cylinder ..... C30Z-7513-A
- 65-71 SB, V8 ..... C60Z-7513-C
- 66-70 6 cylinder ..... C6GY-7513-A
- 67-70 390, 427, 428 ..... C60Z-7513-A
- 71-73 1971 351 & 429; 1972-73 All ..... CSAZ-7513-A

**CLUTCH PILOT BUSHINGS**

A source of vibration in the drivetrain is sometimes a badly worn or cracked clutch pilot bushing.



**Clutch Pilot Bushings**

- 64-66 6 cylinder ..... C0DD-7600-A
- 64-68 289 ..... C20Z-7600-A
- 67-71 Big block ..... C7AZ-7600-B

**Clutch Pilot Bushings**

- 67-73 302, 351 Roller bearing ..... C7AZ-7600-A

**CLUTCH ROD**

Machined to match originals, plated to resist rust. Equalizer to clutch fork. Big block version requires adapter #C80Z-



7B535-A.

**Clutch Rod**

- 65-66 289 ..... C6ZZ-7521-E
- 67-68 289, 302 ..... CZZZ-7521-L
- 67-70 390, 428 ..... C8ZZ-7521-AR
- 69-70 302, 351 ..... C90Z-7521-A

**CLUTCH ROD ADAPTER**

Our adapter is case hardened to OEM specifications and plated for years of service.



**Clutch Rod Adapter**

- 67-71 Big block ..... C80Z-7B535-A

**CLUTCH ROD BUSHING**

Nylon plastic injected. Correct original design. Protects clutch and equalizer rods and removes excess play.



**Clutch Rod Bushing**

- 64-73 ..... C0AZ-7526-B

**CLUTCH ROD TO FIREWALL SEAL**

Molded rubber, mount in firewall. 71-73 version is a combination of steering column and clutch rod seal.



**Clutch Rod to Firewall Seal**

- 64-66 ..... CSZZ-7A533-AR
- 67-70 ..... C60Z-7A533-C
- 71-73 ..... D1ZZ-3513-A

**CLUTCH SPRING**

Spring quality and load matches original.

**Clutch Spring**



- 65-66: 260, 289, 14 1/4" long ..... CSZZ-7523-A



- 66-68: V8, 3 1/8" long ..... C6ZZ-7591-A

**Clutch Spring**



69-70: 4 1/2" long  
C9Z-7523-A

**CLUTCH EQUALIZER**

**CLUTCH EQUALIZER BAR**



Quality fabricated metal stamping. Precision welded. New by Drake.

**Clutch Equalizer Bar**

- 64-65 v8, 5-bolt ..... C4Z-7528-B
- 64-65 High Performance, 5-bolt ..C4Z-7528-C
- 65-66 289 except high performance, 6-bolt .... C5Z-7528-E
- 65-66 High Performance, 6-bolt . C5Z-7528-D
- 67-70 Big block ..... C7Z-7528-B
- 67-70 289, 302, except Boss ..... C7Z-7528-G
- 69 351W ..... C9Z-7528
- 65-66 Clutch Z-bar for PS Conversion ..... C5Z-7528-PSC

**CLUTCH EQUALIZER BAR FELT WASHER**



This felt washer is the correct thickness to replace the missing washers in your equalizer bar. Two required per bar.

**Clutch Equalizer Bar Felt Washer**

- 64-70 Small block, 6 cyl. ....351517-S

**CLUTCH EQUALIZER BAR MOUNT**



**Clutch Equalizer Bar Mount**

- 71-73 302/351, engine side ..... D1ZZ-7A572-A

**CLUTCH EQUALIZER BAR MOUNT KIT**



This kit includes a longer pivot mount. We include bushings, clips and felt washers for both engine and frame side.

**Clutch Equalizer Bar Mount Kit**

- 64-70 6 cylinder, 260, 289 5 bolt C20Z-7A531-K

**Clutch Equalizer Bar Mount Kit**

- 65-70 289 6 bolt, 302, 351W .... C5Z-7A531-K

**CLUTCH EQUALIZER BAR TO PEDAL ROD**



**Clutch Equalizer Bar to Pedal Rod**

- 65 ..... C5Z-7521-A
- 66 13 3/4 inch ..... C6Z-7521-D
- 67-68 12 1/2 inch ..... C7Z-7521-A
- 69-70 12 1/2 inch ..... C9Z-7521-C

**CLUTCH EQUALIZER BUSHING**



Bushing for clutch equalizer bar. Big block only.

**Clutch Equalizer Bushing**

- 67-73 Big block .....C1AA-7543-A

**CLUTCH EQUALIZER PIVOT BRACKET**

This bracket bolts to the frame and acts as the inner pivot point for the clutch equalizer bar.

**Clutch Equalizer Pivot Bracket**



- 64-70: All except big block C5Z-7507-A



- 67-70: Big block, frame side C7Z-7507-BR



- 67-70: Big block, engine side C7Z-7A572-BR

**CLUTCH EQUALIZER REPAIR KIT**



A must for all manual transmissions. Includes felt washers, nylon ball bushings, washer and clevis clips. Improves clutch operation.

**Clutch Equalizer Repair Kit**

- 64-77 6 cylinder, small block ... C1DD-7543-KIT
- 67-73 Big block ..... C1AA-7543-KIT

**CLUTCH EQUALIZER SOCKET**



**Clutch Equalizer Socket**

- 71-73 ..... C0DD-7517-A

**CLUTCH EQUALIZER SOCKET RETAINER**



**Clutch Equalizer Socket Retainer**

- 71-73 ..... C5AZ-7B545-A

**CLUTCH PEDAL**

**CLUTCH PEDAL**



Exact reproductions of the originals. Made in the U.S.A.

**Clutch Pedal**

- 65-66 6 and 8 cylinder ..... C6Z-7519-A
- 67-68 6 and 8 cylinder, requires minor modification for 68 ..... C7Z-7519-A

**AFTERMARKET CLUTCH PEDAL**



These clutch pedals feature an improved design (removable pin) for easier installation. Compatible with existing hanger

assembly even in automatics.

**Clutch Pedal, Aftermarket**

- 65-66 with removable pin .....C6ZZ-7519-AR
- 67-68 with removable pin .....C7ZZ-7519-AR
- 69-70 with removable pin ..... C9ZZ-7519-B
- 71-73 with removable pin ..... D1ZZ-7519-B

**CLUTCH PEDAL BUMPER**

This rubber bumper installs into the clutch pedal. Helps prevent "clunk" when pedal returns back, and properly aligns clutch pedal height.

**Clutch Pedal Bumper**

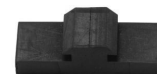

- 67-68 C7Z-7583

Transmission

**WE PROUDLY FEATURE AUTHENTIC MUSTANG REPRODUCTIONS FROM SCOTT DRAKE ENTERPRISES!**



205

**Clutch Pedal Bumper**



69-70  
D0ZZ-7583

**CLUTCH PEDAL PAD**



These reproduction pads are high quality replacements for worn or missing original pads.

**Clutch Pedal Pad**

65-68 ..... CSZZ-7A624-B  
69-73 ..... C9ZZ-7A624-A

**CLUTCH PEDAL PAD TRIM**

Stainless steel.



**Clutch Pedal Pad Trim**

65-68 ..... CSZZ-7B544-A  
69-73 ..... C9ZZ-7B544-A

**CLUTCH PEDAL REPAIR SHAFT**

Includes machined pedal shaft, washer and special pin.



**Clutch Pedal Repair Shaft**

64-70 ..... CSZZ-2478-AK

**CLUTCH PEDAL RETURN SPRING**

Heat treated to match original resistance.  
**Clutch Pedal Return Spring**



64-68: Painted black  
C2AZ-7534-A



69-73: Includes nylon bushings  
C80Z-7534-B

**CLUTCH PEDAL RETURN SPRING BRACKET**

Now available from Scott Drake. Made of heavy gauge steel with a satin black painted finish. Correct threads and hole patterns.  
**Clutch Pedal Return Spring Bracket**



64-66  
CSZ-7535-A

**Clutch Pedal Return Spring Bracket**



67-68  
C7Z-7535-



69-70  
C9Z-7535-A

**CLUTCH PEDAL ROLLER BEARING MASTER REBUILD KIT**



This kit uses roller bearings to reduce pedal pressure and will last for years. 1969 through 1973 may require modification to

the pedal bracket assembly so bushing will fit. 10 piece kit includes instructions.

**Clutch Pedal Roller Bearing Master Rebuild Kit**  
64-73 ..... CSZZ-2478-RBMK

**CLUTCH PEDAL SPRING INSULATOR**



Injection molded plastic stops underdash squeaking from clutch pedal return spring. 2 required per car.

**Clutch Pedal Spring Insulator**

64-68 ..... C1DZ-7A630-A

**CLUTCH PEDAL STOP**



Stamped steel construction, features woven fabric insulator.

**Clutch Pedal Stop**

64-66 ..... C2OZ-7A630-A

**CLUTCH PEDAL SUPPORT BUSHING REPAIR KIT**



An easy fix for sloppy or worn clutch pedal support bushings. Includes 2 machined bushings, 4 plastic bushings and 2

snap rings. 1969 through 1973 may require modification to the pedal bracket assembly so bushing will fit. 8 piece kit includes instructions.

**Clutch Pedal Support Bushing Repair Kit**  
64-73 ..... 378200-K

**CLUTCH PEDAL SUPPORT ROLLER BEARING REPAIR KIT**



These bearings will reduce pedal pressure and last for years. 1969 through 1973 may require modification to the pedal bracket

assembly so bushing will fit. 10 piece kit includes instructions.

**Clutch Pedal Support Roller Bearing Repair Kit**  
64-73 ..... CSZZ-2478-RB

**DIFFERENTIAL**

**BACKING PLATE AXLE GASKET**

Aftermarket authentic gasket.



**Backing Plate Axle Gasket**

64-73 Inner ..... CSZZ-1001-I  
64-73 Outer ..... CSZZ-1001-O

**DIFFERENTIAL GASKET**

Stop those driveway spots with a new differential gasket.



**Differential Gasket**

64-73 8 inch ..... CSZZ-4035-A  
64-73 9" ..... E3TZ-4035-B

**DIFFERENTIAL REBUILD KIT**

Includes crush sleeve, pinion depth shims, pinion seal, gasket, pinion nut, ring gear bolts, carrier side shims, rear pinion bearing and race, front pinion bearing, and race, carrier bearings and races.

**Differential Rebuild Kit**



64-73: 8 inch rear end  
CSZZ-4141-RK



64-73: 9 inch rear end, 28 spline, positraction  
C7Z-4141-RKP28



65-73: 9 inch, 28 spline, non posi  
C7Z-4141-RK028

### DIFFERENTIAL SEAL KIT

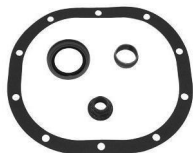

Includes crush sleeve, pinion depth shims, pinion seal and gasket. 9" version pictured. Note: 8" version does not come with actual

gasket. Tube of form-a-gasket included.

#### Differential Seal Kit

64-73 V8, 8 inch rear end ..... CSZZ-4141-SK

64-73 V8, 9 inch rear end ..... C7ZZ-4141-SK

### REAR END VENT HOSE KIT



Rubber hose that allows rear end to breath. Runs from brake junction block up to body. Includes attaching hardware.

#### Rear End Vent Hose Kit

64-70 ..... MVH001

## DRIVELINE

### DRIVELINE SAFETY LOOP



Mounts at seat belt holes to eliminate the need for drilling or welding. Prevents drive shaft from dropping to ground when u-joints fail. A must for all high performance vehicles.

#### Driveline Safety Loop

64-73 ..... CSZZ-4602-L

### U-JOINT



American made aftermarket replacements.

#### U-Joint

64-66 6 cylinder, front, inside snap rings .....

CSZZ-4635-FA

64-66 V8, front, inside snap rings CSZZ-4635-FB

64-66 6 cylinder, rear, inside snap rings .....

CSZZ-4635-RA

64-66 V8, rear, inside snap rings .CSZZ-4635-RB

65-66 V8, rear, outer snap rings .CSZZ-4635-RC

67-73 Front, 3 inch outside diameter yoke span

C7ZZ-4635-FA

67-73 Front, 3 7/8 inch outside diameter yoke

span ..... C7ZZ-4635-FB

67-73 V8, rear, 3 inch outside diameter yoke

span ..... C7ZZ-4635-RA

67-73 V8, rear, 3 7/8 inch outside diameter yoke

span .....C7ZZ-4635-RB

### U-JOINT BOLT KIT



Kit includes 2 concours correct U-Bolts and 4 locking nuts.

#### U-Joint Bolt Kit

64-73 V8 ..... C1AZ-4529-AK

### YOKE



Aftermarket replacement.

#### Yoke

64-73 V8, C-4, 3 or 4 speed, 28 spline cutter snap

rings ..... C3AZ-4841-D

65-70 V8, T-5 ..... T5-YOKE

65-73 Small block, inside snap rings 28 spline ...

C5DZ-4841-A

## NEUTRAL SAFETY SWITCH

### NEUTRAL SAFETY SWITCH



These Neutral Safety Switches were unexpectedly made obsolete by Motorcraft and availability was getting scarce, but

they are now made by Scott Drake and available once again! Our Classic Mustang neutral safety switches are high quality reproduction parts made from original Ford prints.

#### Neutral Safety Switch

64-67 C-4, before 12-15-66 ..... C4AZ-7A247-C

67-69 C-4, C-6, after 12-15-66 .. C9ZZ-7A247-B

### NEUTRAL SAFETY SWITCH

#### HARNES



Very nice, authentic reproduction. Features correct molded connectors.

#### Neutral Safety Switch Harness

64-65 ..... CSZZ-7A240-NS

66 ..... C6ZZ-7A240-NS

## SHIFTER (AUTOMATIC)

### CONSOLE SHIFT SIDE SEAL



Die cut from a tough, wear resistant material which matches the original. Automatic transmissions only.

#### Console Shift Side Seal

64-66 ..... CSZZ-7C445-A

67-68 ..... C7ZZ-7C445-A

### CONSOLE SHIFTER SELECTOR ROD



This is the rod that connects the shifter to the indicator in the console for automatic transmissions.

#### Console Shifter Selector Rod

67-68 ..... C7ZZ-7E148-A

### AUTOMATIC SHIFTER ASSEMBLY



This is a complete shifter including the shift knob. Great chrome and sturdy construction.

#### Shifter Assembly, Automatic

67-68 Console cars only ..... C7ZZ-7210-KIT

### SHIFTER BUSHING



#### Shifter Bushing

64-73 Automatic transmission .. CSZZ-7A133-A

65-67 Automatic transmission, 6 piece kit .....

B9AZ-7343-A

### SHIFTER BUTTON



CSZZ-7C488-C features plastic injection. C8OZ-7C488-A features die-cast zinc construction and chrome plating.

#### Shifter Button

64-73 Black ..... CSZZ-7C488-C

68-71 Chrome plated, Left hand C8OZ-7C488-A

69-73 Black ..... C9ZZ-7C488-C

WE PROUDLY FEATURE AUTHENTIC MUSTANG REPRODUCTIONS FROM SCOTT DRAKE ENTERPRISES!





### SHIFTER CABLE

Repair cable for shifter lever.



**Shifter Cable**  
65-73 Automatic transmission .. C5ZZ-7D246-A

### SHIFTER COVER ASSEMBLY

Quality chrome finish over zinc die cast. Features correct details and paint. Seal & Dial included. For 64-68 Mounting Screws order part #52720-SK.  
**Shifter Cover Assembly**



64: Concours, without arrows  
C4ZZ-7D394

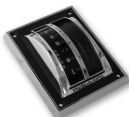

65-66: Concours  
C5ZZ-7D394

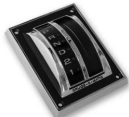

67-68: Not exact copy  
C7ZZ-7D394

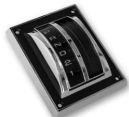

67-68: Concours  
C7ZZ-7D394-P



69-70: Concours, will also fit 1971-73 for an upgraded look  
C9ZZ-7D394



71  
D1ZZ-7D443-A

### SHIFTER COVER ASSEMBLY AND HANDLE KIT



Includes shift handle, cover assembly, new bushings and mounting hardware.

**Shifter Cover Assembly and Handle Kit**  
64-66 .....KIT-TRN-1  
67-68 .....KIT-TRN-2

### SHIFTER COVER RETAINING PLATE

Painted black steel stamping. Fits under the shift bezel, on top of the shift lever bucket.

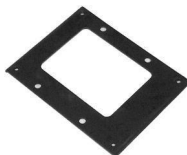

**Shifter Cover Retaining Plate**  
64-68 w/out Console ..... C5ZZ-7B233-A

### SHIFTER DIAL

Precision molded clear plastic with black or clear background under red arrows and white letters.

#### Shifter Dial



64: Early 64, Black, no arrows, non-console  
C4ZZ-7A213-A



64-66: Black, for center console  
C5ZZ-7A213-D



65-66: Black, non-console  
C5ZZ-7A213-A



67-68: Black, non-console  
C7ZZ-7A213-A



69-70: Clear, no arrows, All  
C9ZZ-7E271-A



69-73  
C9ZZ-7A110-A

### AUTOMATIC SHIFTER HANDLE

A variety of shift handles to match your vehicle. Note: C5ZZ-7213-F is an exact copy of the 65-68 version.  
69-73 standard



Chrome

interior shift handle was slightly different in appearance. Early 1964 cars had a smaller handle.

#### Shifter Handle, Automatic

64-73 Chrome, concours .....C5ZZ-7213-F  
67-68 Parchment, deluxe ..... C80Z-7213-PR

#### Shifter Handle, Automatic

67-68 Saddle, deluxe ..... C80Z-7213-SA  
67-69 Dark blue, deluxe ..... C80Z-7213-BL  
67-73 Black, deluxe ..... C80Z-7213-BK  
67-73 Black, leather, deluxe ....C80Z-7213-BKL  
68-69 Maroon, deluxe ..... C80Z-7213-MR  
69-73 Chrome, concours .....C90Z-7213-B

### SHIFTER HOUSING TO FLOOR SEAL

Die-cut rubber.



#### Shifter Housing to Floor Seal

65-68 ..... C5ZZ-7370  
69-73 ..... C9ZZ-7370

### SHIFTER LINKAGE ROD

Our linkage rod includes the connector that is often worn and not included with the competitions linkage rod. Dark grey finish to



prevent rust.

#### Shifter Linkage Rod

64-66 C-4 ..... C5ZZ-7326-A  
67-68 C-4 ..... C7ZZ-7326-A

### CONSOLE SHIFTER PLATE ASSEMBLY



Precision stamped steel construction, painted black, includes shift dial, selector slide and proper hardware.

#### Shifter Plate Assembly, Console

65-66 ..... C5ZZ-7D350-K

### SHIFTER SEAL

High quality rubber molded around a flexible steel insert. Insert is cadmium plated to prevent rust.

#### Shifter Seal



64-68: Non-console  
C5ZZ-7D351



69-73: All  
D1ZZ-7D351-A

**AUTOMATIC SHIFTER SELECTOR LEVER**



Chrome plated lever with new cable, bushings and internal mechanisms.

**Shifter Selector Lever, Automatic**

64-68 64-66: All / 67-68: without console .....

C5ZZ-7210-A

69-73 69-73: All .....C9ZZ-7210-A

**TRANSMISSION KICK DOWN CABLE KIT**

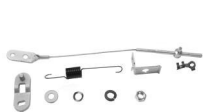

A 9-piece kit, our Transmission Kick Down Cable Kit includes our cable, lever, spring & bracket, along with all the

hardware for simple installation.

**Transmission Kick Down Cable Kit**

66-68 .....C60Z-7A187-KIT

**KICKDOWN LEVER**

**KICKDOWN LEVER**



Stamped steel construction with welded machined stud.

**Kickdown Lever**

67-68 6 and 8 cylinder .....C60Z-7D026

**SHIFTER (MANUAL)**

**SHIFT LEVER GROMMET**



Replace those worn out or missing shift lever grommets to fix that sloppy shift lever.

**Shift Lever Grommet**

64-70 Bulk .....379998-S

64-73 Pair, packaged .....379998-SK

**SHIFT LEVER REBUILD KIT**



This kit is used to keep tension on the shifter where it connects to the shift linkage. A sign that this kit is needed is a wobbly, loose shift

lever.

**Shift Lever Rebuild Kit**

64-68 4speed .....C5ZZ-7208-A

**Shift Lever Rebuild Kit**

65-68 3speed .....C5ZZ-7208-B

**SUPER SHIFT LEVER REBUILD KIT**



This kit is used to keep tension on the shifter where it connects to the shift linkage. A sign that this kit is needed

is a wobbly, loose shift lever. Kit includes shoulder bolts.

**Shift Lever Rebuild Kit, Super**

64-68 4speed .....C5ZZ-7208-AK

64-68 3speed .....C5ZZ-7208-BK

**SHIFT LEVER SHOULDER BOLT**



Not always included in shifter rebuild kits, but necessary for a complete shifter rebuild. These are NOT generic bolts, they are

exact copies. High grade zinc plated bolts. Correct shoulders and nylon lock.

**Shift Lever Shoulder Bolt**

65-68 .....379818-S

**HURST COMPETITION/PLUS SHIFTER**



The industry standard for over 30 years, this shifter offers state of the art transmission control for popular 4-speed manual

transmissions. Dedicated applications assure a custom fit to a wide variety of vehicles having factory consoles without any floor pan modifications " Race track proven design and reliability. " Heat treated linkage rods and arms for added strength and durability. Adjustable gear stops prevent overshifts to help prolong transmission life. Bolt-on chrome-plated stick with attractive custom white knob. Complete with all hardware. \*SHIFTER AND INSTALLATION KITS ARE SOLD SEPARATELY\*

**Shifter, Hurst Competition/Plus**

64-73 4 speed, Shifter only (for T-10 or Toploader) .....H-3913180

64-73 4-speed Toploader install kit for H-3913180 .....H-3737637

**MANUAL SHIFTER**



Factory detailing and triple chrome plating distinguish our tubular shift handles from the rest. Cable and T-lever included.

**Shifter, Manual**

65-67 4-speed .....C5ZZ-7210-M

**Shifter, Manual**

65-67 5-speed .....C5ZZ-7210-T

68 4-speed .....C8ZZ-7210-A

**SHIFTER BRACKET**



This previously hard to find part comes complete with proper fitting shaft.

**Shifter Bracket**

65-67 3 and 4 speed .....C5ZZ-7210-D

**GENUINE LEATHER SHIFTER BOOT**



These leather shift boots look great! Our 64-73 boots feature draw string at the neck and rubber insulated metal mounting plate.

**Shifter Boot, Genuine Leather**

64-68 Leather with draw string ...C5ZZ-7277-L

69-73 Leather with draw string ...C9ZZ-7277-L

**LOWER SHIFTER BOOT**



This rubber boot mounts on the shifter housing underneath the shift boot. Most cars are missing this important part. It was

designed to keep dirt and moisture out of the shifter box and reduce noise coming through the shifter hole. An excellent reproduction.

**Shifter Boot, Lower**

65-68 3 speed .....C6ZZ-7138-B

65-68 4 speed, small block .....C6ZZ-7138-C

69 4 speed .....C9ZZ-7138-B

70 4 speed hurst .....D0GZ-7138

**RUBBER SHIFTER BOOT**



An exact copy of the original. Compression molded E.P.D.M. rubber. Features a textured skin that matches the original

appearance exactly. Ours has a steel insert just like the originals.

**Shifter Boot, Rubber**

64-68 3 and 4 speed .....C5ZZ-7277-B

69-70 3 and 4 speed .....C9ZZ-7277-A

70 Hurst, 4 speed .....D0ZZ-7277-B

Transmission

**WE PROUDLY FEATURE AUTHENTIC MUSTANG REPRODUCTIONS FROM SCOTT DRAKE ENTERPRISES!**



## SHIFTER BOOT RETAINER

These pieces really dress up the area around the shifter.

### Shifter Boot Retainer

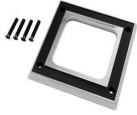

64-68: Chrome, Deluxe, 3 and 4 speed, without console \*Rare Original Option\*  
C4ZB-7262-B

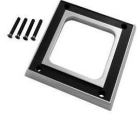

64-68: Satin, Deluxe, 3 and 4 speed, without console  
C4ZB-7262-S



64-68: Chrome, manual transmission without console  
CSZZ-7262-C



69-70: Chrome, manual transmission  
C9ZZ-7262-C

## BILLET MANUAL SHIFTER KNOB

\*  A variety of shift knobs to put a nice touch on your shifter.

### Shifter Knob, Billet Manual



64-73: Mustang logo, 4 Speed, 1/2" x 20"  
CSZZ-7213-BL



64-66: Black, 4 speed, 1/2" x 20  
B-7213-A



64-66: Satin, 4 speed, 1/2" x 20  
B-7213-AC



67-68: Satin, 4 speed, 1/2" x 20  
B-7213-BC



68-69: Black, deluxe, 4 speed, 1/2" x 20  
B-7213-C

### Shifter Knob, Billet Manual



68-69: Satin, deluxe, 4 speed, 1/2" x 20  
B-7213-CC



64-66: Satin, 5 speed, 12 mm threads  
B-7213-ESAC



65-70: Satin, 4 speed, Hurst threads, 3/8" x 16  
B-7213-HC



68-69: Black, deluxe, 5 speed, 1/2" x 20 threads  
B-7213-T5C

## ORIGINAL MANUAL SHIFTER KNOB

Truly a fine reproduction made from the same material as the originals.

### Shifter Knob, Original Manual



64-66: Black, original Bakelite plastic, 4 speed  
CSZZ-7213-A



64-67: Black, original Bakelite plastic, 3 speed, 1/2" x 20  
CSZZ-7213-H



65-67: Black, original Bakelite plastic, 5 speed  
CSZZ-7213-T5



67-68: Black, original Bakelite plastic, 4 speed  
C7ZZ-7213-A



67-68: Black, original Bakelite plastic, 5 speed  
C7ZZ-7213-T5



67-68: Black, original Bakelite plastic, 3 speed, 7/16" x 20  
C80Z-7213-B



68-69: Woodgrain, deluxe, plastic injection copy of original, 4 speed  
C80Z-7213-A

### Shifter Knob, Original Manual



68-69: Woodgrain, deluxe, Plastic injection, 5 speed, 1/2" x 20 threads  
C80Z-7213-T5

## SHIFTER KNOB, WHITE



Mustang four speed gear shift ball with shift pattern and red running horse logo positioned

on each side. Thread size is 1/2" x 20.

### Shifter Knob, White

64-73 Mustang, running horse 4 speed \* .....  
..... CSZZ-7213-W4

## SHIFT KNOB RETAINING NUT



### Shift Knob Retaining Nut

68-69 1/2" x 20 ..... C80A-7C404-A

## SHIFTER LINKAGE



4 speed top loader linkage includes 3 rods, 3 arms, 6 washers and 6 pins. Fits Mustang and Cougar only.

### Shifter Linkage

64-68 ..... CSZZ-7285-LRK

## 4-SPEED SHIFTER INTERLOCK WASHER



Fits inside the shifter box between shift levers. This washer is made from the original Ford print for a perfect fit. Features heat-

treated steel with a zinc finish.

### Shifter Interlock Washer, 4-Speed

64-69 ..... CSZZ-7C318-A

## SHIFTER LINKAGE RETAINING CLIP



Heat treated wire clip that secures shift linkage rod. Automatic or manual transmission.

### Shifter Linkage Retaining Clip

64-73 ..... 352358-S

### SHIFTER MOUNT PLATE



Plate mounts the shifter to the transmission. Top loader only.

**Shifter Mount Plate**  
64-73 4speed ..... CSZZ-7E046-T

### SHIFTER MOUNTING PLATE EXTENSION



This conversion plate allows the use of a Falcon, Fairlane or Torino 4 speed toploader to be installed into a

Mustang. Relocates shifter rearward to correct position.

**Shifter Mounting Plate Extension**  
64-73 4speed ..... CSZZ-7E046-A

## SPEEDOMETER CABLES & GEARS

### SPEEDOMETER CABLE



Quality aftermarket copies. Attaches from rear of speedometer to transmission. Now come with correct firewall grommet, a

Scott Drake exclusive!  
**Speedometer Cable**

64-66 Automatic transmission and 3 speed, 60 inches long ..... CSDZ-17260-A  
64-66 4 speed, 68 inches long .. CSOZ-17260-A  
67-68 Automatic transmission and 3 speed, 68 inches long ..... C7ZZ-17260-A  
67-68 4speed ..... C7ZZ-17260-B  
69-70 4 speed, except drag pack C9ZZ-17260-B  
69-73 Automatic transmission and 3 speed ..... C9ZZ-17260-A



New by Drake is our 1969-73 Mustang Speedometer Cable To Transmission Retainer. This is an exact copy of Retaining Bracket

used on 69-73 Mustangs, Cougars and misc other Fords to hold the Speedo Cable into the Transmission Housing. Fits Automatic and Manual Transmissions. Silver Zinc Plated.

**Speedometer Cable Retainer.** ..... B9TZ-17264-A

### SPEEDOMETER GEAR



Injection molded nylon. Please confirm teeth count and teeth direction. Note: 4 speed toploaders have reversed tooth

direction. Also note: color matching does not guarantee correct gear. Note: not returnable if package is opened.

#### Speedometer Gear

64-73 16 teeth, automatic transmission and 3 speed ..... CODZ-17271-A  
64-73 16 teeth, 4 speed Toploader (orange) .... C2DZ-17271-J  
64-73 17 teeth, automatic transmission and 3 speed ..... CODZ-17271-C  
64-73 17 teeth, 4 speed Toploader (purple) ..... C2DZ-17271-G  
64-73 18 teeth, automatic transmission and 3 speed (yellow) ..... C0DD-17271-B  
64-73 18 teeth, 4 speed Top-Loader ..... C2DZ-17271-A  
64-73 19 teeth, automatic transmission and 3 speed (pink) ..... CODZ-17271-B  
64-73 19 teeth, 4 speed Toploader ..... C2DZ-17271-B  
64-73 20 teeth, automatic transmission and 3 speed (black) ..... C1DZ-17271-A  
64-73 20 teeth, 4 speed Toploader ..... C2DZ-17271-C  
64-73 21 teeth, automatic transmission and 3 speed ..... CODZ-17271-D  
64-73 21 teeth, 4 speed Toploader ..... C2DZ-17271-D

### INTERNAL SPEEDOMETER GEAR



#### Speedometer Gear, Internal

64-66 3:50 to 4:30 rear axel ratio. 6 teeth, 4 speed Toploader (pink) ..... CSZZ-17285A  
64-73 2:70 to 3:50 rear axel ratio. 7 teeth, 4 speed Toploader (black) ... C4DZ-17285A

### SPEEDOMETER GEAR RETAINING CLIP



Secures speedometer cable gear to the end of the cable.

**Speedometer Gear Retaining Clip**  
64-73 ..... C1DZ-17292-A

## TRANSMISSION CONVERSION PARTS

### T5 CONVERSION KIT



These conversion kits makes it easy to install a late model V8 T5 transmission in a 1965-70 Mustang. T5 transmissions will

increase gas mileage and top end speed. No cutting of the floor pan required. Bell housing modification required. Bell housing not included. Spacer plate included on original kit.

#### T5 Conversion Kit

65-66 T-5 bellhousing ..... T5-65-KIT  
65-66 Original 6-bolt bellhousing, 289, 302 .... T5-650E-KIT  
67-70 T-5 bellhousing ..... T5-67-KIT  
67-70 Original bellhousing, 289, 302 ..... T5-670E-KIT

### TRANSMISSION SPACER PLATE CONVERSION KIT



Allows you to retain your original 6-bolt bellhousing when using a 1985-1993 T5 5-speed transmission. Requires drilling 2

holes into bellhousing.

#### Transmission Spacer Plate Conversion Kit

65-70 T-5V8, 6 bolt ..... T5-PLATE-KIT6

### TRANSMISSION CROSSMEMBER BAR



This is required to convert your car to a T5 five speed transmission. 65-66 version includes parking brake bracket.

#### Transmission Crossmember Bar

65-66 T-5, V8 ..... T5-BAR-A  
67-70 T-5, V8 ..... T5-BAR-B  
65-66 Tremec ..... TREMEC-65CM

### TRANSMISSION FULCRUM



This is required to convert a late model T-5 bell housing to accept the early Mustang clutch fork. Available for 65-67

spring type clutch forks and for 68-70 prong type clutch forks.

#### Transmission Fulcrum

65-67 Spring type ..... T5-FSB-KIT-A  
68-70 Prong type ..... T5-FSB-KIT-B

**WE PROUDLY FEATURE AUTHENTIC MUSTANG REPRODUCTIONS FROM SCOTT DRAKE ENTERPRISES!**



## TRANSMISSION MOUNT



Perfect replacement for your broken tranny mount. Also can be used when converting to T-5

**Transmission Mount**  
64-73 All .....C4DZ-6068-A

## TRANSMISSION MOUNT BOLTS



Concours correct. 67-70 available Summer 2012 under part #356682-S.

**Transmission Mount Bolts**  
64-66 2 Bolts & 2 Nuts .....372993-S



**Transmission Mount Bolts**  
64-73 All Applications -2 Bolts .....372821-S

## TRANSMISSION FLYWHEELS, RING GEARS, AND BELLHOUSINGS

### TRANSMISSION FLYWHEEL



American aftermarket brand at a fantastic price.

**Transmission Flywheel**  
64-68 157 teeth, 289, 3 and 4 speed .....  
C3AZ-6375-J  
64-73 164 teeth, 302, 351 .....C6TZ-6375-C

### TRANSMISSION RING GEAR



Made by a premier manufacturer in the U.S.A. All are top quality. Easily replaces those missing or damaged teeth on

flywheels.

**Transmission Ring Gear**  
64-68 157 teeth, 260, 289 .....C20Z-6384-B  
68-73 164 teeth, 302, 351 .....C5AZ-6384-D  
67-70 184 teeth, 390, 428 .....C5AZ-6384-A

## TRANSMISSION GEARS, SYNCHROS AND SHAFTS

### TRANSMISSION CLUSTER GEAR



Aftermarket U.S. brand.

#### Transmission Cluster Gear

64 3 speed, 170 .....C1DR-7113-A  
65-66 3 speed, 200 .....C50Z-7113-A  
64-73 3 speed, 64-73 8 Cylinder, 67-73 6  
Cylinder .....C5AZ-7113-G  
65 4 speed, T10, 17 teeth .....C30Z-7113-C  
64-73 4 speed Toploader, 2.32 ration .....  
C4AZ-7113-B  
64-66 4 speed Toploader, 2.78 ratio .....  
C4DZ-7113-B

### TRANSMISSION COUNTERSHAFT

#### PIN



Quality machined pin, aftermarket brand.

#### Transmission Countershaft Pin

64-66 3 speed, 6 cylinder .....C0DR-7111-A  
64-73 4 speed Toploader, 10 1/8 inches long,  
.8920 inch diameter .....C4AZ-7111-A

### TRANSMISSION GEAR



Made in the U.S. Premium brand.

#### Transmission Gear

64-66 Reverse idler gear, 3 speed, 6 cylinder ....  
C1DR-7141-A  
64-73 Reverse idler gear, 3 speed, 64-73 8  
cylinder, 67-73 6 cylinder ..C5AZ-7141-C  
64-73 Reverse idler gear, 4 speed Toploader ....  
C4AZ-7D223-B  
64-66 Reverse idler gear, Borg Warner T-10 4  
speed .....C2AZ-7141-B  
64-66 1st/reverse, 3 speed, 6 cylinder .....  
C1DR-7100-A  
64-73 1st gear, 3 speed, 64-73 8 cylinder, 67-73  
6 cylinder .....C5AZ-7A029-C  
64-73 1st gear, 32 teeth, 4 speed Toploader ....  
C4AZ-7A209-A  
64-66 1st gear, 36 teeth, Borg Warner T-10 4  
speed .....C2AZ-7100-C

#### Transmission Gear

64 2nd gear, 19 teeth, 3 speed, 170 .....  
C1DZ-7102-B  
65-66 2nd gear, 20 teeth, 3 speed, 6 cylinder ...  
C50Z-7102-A  
64-73 2nd gear, 25 teeth, 3 speed, 65-73 8  
cylinder, 67-73 6 cylinder ..C5AZ-7102-F  
64-73 2nd gear, 28 teeth, 4 speed Toploader ....  
C4AZ-7102-D  
64-66 2nd gear, 31 teeth, 4 speed Toploader ....  
C4DZ-7102-A  
65-73 1st gear, 32 teeth, 4 speed Toploader .....  
C4AZ-7A029-A  
64-73 3rd gear, transmission with 2.32 1st gear  
ratio, 4 speed Toploader ..C4AZ-7B340-C  
64-66 3rd gear, transmission with 2.78 1st gear  
ratio, 4 speed Toploader ..C4DZ-7B340-B  
65-66 3rd gear, 28 teeth, Borg Warner T-10 4  
speed .....C30Z-7B340-B

### TRANSMISSION INPUT SHAFT



Quality aftermarket brand, U.S.A.

#### Transmission Input Shaft

64 16 teeth, 3 speed, 170 .....C2DZ-7017-B  
65-66 8 3/4 inches, 3 speed, 65-66 8 cylinder,  
67-73 6 cylinder .....C5AZ-7017-B  
66 8 3/4 inches, 3 speed, 6 cylinder .....  
C60Z-7017-A

### TRANSMISSION MAINSHAFT



Made in U.S.A. Quality built.

#### Transmission Mainshaft

64-66 25 spline, 3 speed, 6 cylinder .....  
C20Z-7061-B

### TRANSMISSION SYNCHRONIZER



All made from name brand supplies. All U.S.A.

#### Transmission Synchronizer

64-73 1st gear and reverse, 3 speed, 64-73 8  
cylinder, 67-73 6 cylinder ..C6AZ-7124-B  
64-73 1st and 2nd gear, with reverse, 4 speed  
Toploader .....C4AZ-7124-B  
64-66 1st and 2nd gear, 36 teeth, Borg Warner  
T-10 4 speed .....C2AZ-7124-H

### Transmission Synchronizer

- 64-73 2nd and 3rd gear, 3 speed, 6 cylinder ..... C2DZ-7124-A
- 64-73 2nd and 3rd gear, 3 speed, 64-73 8 cylinder, 67-73 6 cylinder .. C8TZ-7124-G
- 64-73 3rd and 4th gear, 4 speed Toploader ..... C4AZ-7107-D
- 64-66 3rd and 4th gear, Borg Warner T-10 4 speed ..... C2AZ-7124-C

### TRANSMISSION SYNCHRONIZER FORK



#### Transmission Synchronizer Fork

- 64-73 1st and 2nd gear, 4 speed Toploader ..... C4AZ-7230-B
- 64-66 1st-4th gear, Borg Warner T-10 4 speed . C2AZ-7230-A
- 64-73 3rd and 4th gear, 4 speed Toploader ..... C4AZ-7230-A

## TRANSMISSION KITS

### AUTOMATIC TRANSMISSION MASTER REBUILD KIT



These kits include everything necessary to rebuild your tired and leaking automatic transmission. Parts included are all paper

gaskets, pan gasket, rubber O rings, rubber lip seals, metal clad seals, sealing rings, friction clutches, steel clutch plates, filter, clutch band, and bushings. Vacuum modulator sold separately.

#### Automatic Transmission Master Rebuild Kit

- 64-69 C-4 ..... C5ZZ-7005-MK
- 67 C-6 ..... C7ZZ-7005-MK
- 68-73 C-6 ..... C8ZZ-7005-MK
- 69-73 FMX ..... C9ZZ-7005-MK
- 70-73 C-4 ..... D0ZZ-7005-MK

### AUTOMATIC TRANSMISSION OVERHAUL KIT



This kit includes all paper gaskets, pan gasket, rubber O rings, rubber lip seals, metal clad seals, sealing rings & friction clutches.

Vacuum modulator sold separately.

#### Automatic Transmission Overhaul Kit

- 64-69 C-4 ..... C5ZZ-7005-K

### Automatic Transmission Overhaul Kit

- 67-73 C-6 ..... C7ZZ-7005-K
- 69-73 FMX ..... C9ZZ-7005-K
- 70-73 C-4 ..... D0ZZ-7005-K

### AUTOMATIC TRANSMISSION SHIFT KIT



#### KIT

These shift kits are a must for anybody wishing to improve economy, performance and durability of their

automatic transmission. Shift kits firm up 1-2 and 2-3 shifts and improve passing gear response.

#### Automatic Transmission Shift Kit

- 65-66 C-4, Cruise-o-matic, basic kit ..... C5ZZ-7A100-SK
- 67-69 C-4, Select-o-matic, reprogramming kit ... C7ZZ-7A100-RPK
- 67-69 C-4, Select-o-matic, basic kit ..... C7ZZ-7A100-SK
- 67-73 C-6, basic kit ..... C8ZZ-7A100-SK
- 69-73 FMX, basic kit ..... C9ZZ-7A100-SK
- 70-72 C-4, basic kit ..... D0ZZ-7A100-SK
- 70-73 C-4, Select-o-matic, reprogramming kit ... D0ZZ-7A100-RPK
- 73-80 C-4 and C-5, basic kit ..... D3ZZ-7A100-SK

### MANUAL TRANSMISSION MASTER REBUILD KIT



Master rebuild kits include brass synchro rings, input and output oil seals, tailshaft bushing, input and output bearings and

all paper gaskets. Most also include thrust washers, needle bearings and small parts kit. Please refer to photo for contents of each kit.

#### Manual Transmission Master Rebuild Kit

- 64-65 Borg Warner T-10 4 speed, V8 ..... C5ZZ-7005-R4B
- 64-66 3 speed, 2.77 ratio, 6 cylinder ..... C3DZ-7005-R3
- 64-73 3 speed, 64-73 8 cylinder, 67-73 6 cylinder ..... C5ZZ-7005-R3
- 64-73 4 speed Toploader, V8 except 427, 428, 429 ..... C5ZZ-7005-R4T
- 67-73 4 speed Toploader with 1 3/8 inch input, Big block ..... C7ZZ-7005-R4T

### MANUAL TRANSMISSION OVERHAUL KIT



These kits are the same as Master Rebuild Kits except they do not include brass synchro rings.

#### Manual Transmission Overhaul Kit

- 64-65 Borg Warner T-10 4 speed, V8 ..... C3DZ-7005-OH4B
- 64-66 3 speed, 2.77 ratio, 6 cylinder ..... C3DZ-7005-OH3
- 64-73 3 speed, 64-73 8 cylinder, 67-73 6 cylinder ..... C5ZZ-7005-OH3
- 64-73 4 speed Toploader, V8, except 427, 428, 429 ..... C5ZZ-7005-OH4T
- 67-73 4 speed Toploader with 1 3/8 inch input, Big block ..... C7ZZ-7005-OH4

## TRANSMISSION OIL PARTS

### TRANSMISSION DIP STICK



All dip sticks have correct markings for accurate readings.

#### Transmission Dip Stick

- 64-73 C-4, zinc ..... C6AZ-7A020-B
- 64-73 C-4, chrome ..... C6AZ-7A020-C
- 65-73 Billet w/ Stick ..... B-7A020

### TRANSMISSION DIP STICK TUBE



Fits C4 transmissions. O-ring included

#### Transmission Dip Stick Tube

- 64-73 C-4, black ..... C60Z-7A228-B
- 64-73 C-4, chrome ..... C60Z-7A228-C

### TRANSMISSION FILTER



Clean filters are essential for proper transmission function and longevity.

#### Transmission Filter

- 64 C-4, with gaskets ..... C4ZZ-7A098-F
- 65-69 C-4, with gaskets ..... C5ZZ-7A098-F
- 67-73 C-6, with gaskets ..... C7ZZ-7A098-F
- 69-73 FMX, with gaskets ..... C9ZZ-7A098-F
- 70-73 C-4, with gaskets ..... D0ZZ-7A098-F

**WE PROUDLY FEATURE AUTHENTIC MUSTANG REPRODUCTIONS FROM SCOTT DRAKE ENTERPRISES!**



## TRANSMISSION OIL COOLER

### FITTING



Brass fitting which screws into radiator oil cooler.

Transmission Oil Cooler Fitting  
67-73 .....MOCF01

## TRANSMISSION OIL COOLER HOSE

### KIT



Connects transmission oil cooler lines to transmission oil cooler in radiator. Includes hoses, fittings and post clamps.

Transmission Oil Cooler Hose Kit  
64-65 6 cylinder or 8 cylinder ..... MOC001

## TRANSMISSION OIL COOLER LINE

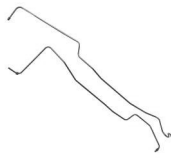

Quality precision bent lines. Runs from oil cooler in radiator to transmission. Does not include rubber hoses or clamps on

1964-1965 models. Each pair does include two retainer clips.

Transmission Oil Cooler Line	
64-65 6 cylinder, steel	.....MOL001
64-65 6 cylinder, stainless steel	.....MOL001S
64-65 V8, steel	.....MOL003
64-65 V8, stainless steel	.....MOL003S
66 6 cylinder, steel	.....MOL004
66 6 cylinder, stainless steel	.....MOL004S
66 V8, steel	.....MOL005
66 V8, stainless steel	.....MOL005S
67-70 C-4, V8, steel	.....MOL002
67-70 C-4, V8, stainless steel	.....MOL002S
67-70 C-6, 390, 428, steel	.....MOL006
67-70 C-6, 390, 428, stainless steel	.....MOL006S
67-70 C-4, 6 cylinder, steel	.....MOL010
67-70 C-4, 6 cylinder, stainless steel	..MOL010S
69-70 FMX, 351, steel	.....MOL007
69-70 FMX, 351, stainless steel	.....MOL007S
71 FMX, steel	.....MOL011
71-73 C-4, 302, steel	.....MOL008
71-73 C-4, 302, stainless steel	.....MOL008S
71-73 C-6, 351C, steel	.....MOL009
71-73 C-6, 351C, stainless steel	.....MOL009S
71-73 FMX, stainless steel	.....MOL011S

## TRANSMISSION OIL LINE BRACKET



Mounts to front right hand side of engine, holds transmission cooler lines in place to prevent damage.

Transmission Oil Line Bracket  
64-66 V8 ..... MTLB01

## TRANSMISSION OIL LINE RETAINER

### CLIP



These retainer clips were specially tooled up, not a generic clip. Holds transmission lines together. Made from spring steel, black

oxide finish.  
Transmission Oil Line Retainer Clip  
64-73 .....LRC101

## C-6 TRANSMISSION PAN



Steel stamped construction.

Transmission Pan, C-6  
67-73 C-6, chrome with drain plug .....  
C7ZZ-7A194-A

## CONCOURS C-4 TRANSMISSION PAN

Stamped steel construction.  
Transmission Pan, Concours C-4



64-73: C-4, chrome  
C5ZZ-7A194-C

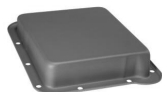

64-73: C-4, natural gray  
C5ZZ-7A194-S



64-73: C-4, chrome with drain plug, aftermarket  
C5ZZ-7A194-A

## DEEP C-4 TRANSMISSION PAN



Stamped steel construction. These are 1" deeper than stock depth. Allows you to run approximately 1.5 to 2 quarts more fluid to keep your transmission cooler and extend

your transmissions life.

Transmission Pan, Deep C-4  
64-73 C-4, 1 inch deeper, chrome .....  
C5ZZ-7A194-CD  
64-73 C-4, 1 inch deeper, natural gray .....  
C5ZZ-7A194-SD

## TRANSMISSION PLATES

### AUTOMATIC TRANSMISSION C4

#### VERTER NUTS



Set of 4 unique flanged lock nuts. Fits all automatic applications. Concourse correct.

Automatic Transmission C4 Tourque Converter Nuts  
64-73 Set of 4 .....377704-S

### AUTOMATIC TRANSMISSION FLEX

#### ATE



All new, not rebuilt. Precision welded and balanced. Includes new ring gear.

Automatic Transmission Flex Plate  
64-72 C-4, 157 teeth, 289, 302 ... C3AZ-6375-L  
67-70 C-6, 184 teeth, 390 .....C7AZ-6375-B  
68-70 428, non SCJ ..... C8AZ-6375-C  
68-73 C-4 and FMX, 164 teeth, 302, 351W .....  
C9AZ-6375-A

### AUTOMATIC TRANSMISSION

#### INSPECTION PLATE

A nice reproduction of a commonly missing part. Helps keep dirt and debris out of the bell housing.

Automatic Transmission Inspection Plate



64-73: C-4, zinc  
C5DZ-7986-B



64-73: C-4, chrome  
C5DZ-7986-C



66-70: C-6, black  
C6AZ-7986-A

**AUTOMATIC TRANSMISSION SPACER PLATE**



Stamped steel spacer plate goes between engine and bell housing. Fits 157 teeth flywheels only.

**Automatic Transmission Spacer Plate**  
65-68 C-4, 289, 6 bolt ..... C5ZZ-7007/7986

**MANUAL TRANSMISSION SPACER PLATE**



Plate that is required to give proper spacing for flywheel and starter, also used to reinforce starter mounting.

**Manual Transmission Spacer Plate**  
64-65 Small block, 5 bolt ..... C4DZ-7007-A  
65-68 289, 6 bolt, 157 teeth ..... C5DZ-7007-A  
68-73 302, 164 teeth ..... C9DZ-7007-A

**TRANSMISSION FLYWHEEL BOLTS**



Fits all manual transmission flywheels and will work on automatic transmission flexplates when factory

reinforcement plate is used. 15/16" long.  
**Transmission Flywheel Bolts**  
64-73 ..... B8AZ-6379-A

**VACUUM MODULATOR**

**VACUUM MODULATOR**



American made. Premium aftermarket brand.

**Vacuum Modulator**  
64-71 64-71 C-4, 66-72 C-6 ..... C4AZ-7A377-B

**VACUUM MODULATOR LINE**



**Vacuum Modulator Line**  
64-65 C-4, V8, steel ..... MVT002  
64-65 C-4, V8, stainless steel ..... MVT002S  
64-68 6 cylinder, steel ..... MVT003  
64-68 6 cylinder, stainless steel ..... MVT003S  
65-66 C-4, steel ..... MVT001  
65-66 C-4, stainless steel ..... MVT001S  
67-69 C-4, V8, steel ..... MVT004

**Vacuum Modulator Line**

67-69 C-4, V8, stainless steel ..... MVT004S  
68-69 C-6, V8, steel ..... MVT007  
68-69 C-6, V8, stainless steel ..... MVT007S  
71-73 C-4, V8, steel ..... MVT005  
71-73 C-4, V8, stainless steel ..... MVT005S  
71-73 C-6, 351, steel ..... MVT006  
71-73 C-6, 351, stainless steel ..... MVT006S

**TRUNK COMPARTMENT**

**BAGS & ACCESSORIES**

**CONVERTIBLE TOP BOOT BAG**

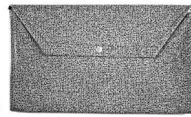

Large envelope used to hold top boot, helps keep boot clean and damage free.

**Convertible Top Boot Bag**  
64-73 Speckled ..... BB-FM-SPK

**FIRE EXTINGUISHER MOUNT**



NHRA approved, the Drake Fire Extinguisher Mount is machined from 6061-T6 billet aluminum and features a laser etched logo. Fits various sizes of automobile fire extinguishers.

**Fire Extinguisher Mount**  
64-73 ..... FIREX-MNT-DAG  
64-73 ..... FIREX-MNT-DOR

**FIRE EXTINGUISHER MOUNT CLAMPS**



Heavy Duty T-Bar style band clamps. Each set comes with 4 clamps: 2 for securing your fire extinguisher to our Drake Fire Extinguisher

Mount (FIREX-MNT-DAG), and 2 for securing the mount to a roll bar in your vehicle. These clamps fit MaxOut fire extinguishers (MX100R or MX250R).

**Fire Extinguisher Mount Clamps**  
64-73 Large, fits MaxOut fire extinguisher MX250R ..... FIRE-CLMP-L-DAG  
64-73 Small, fits MaxOut fire extinguisher MX100R ..... FIRE-CLMP-S-DAG

**JACK BAG**



Organized way to keep the jack clean and help reduce quarter panel damage from jack hitting the interior.

**Jack Bag**  
64-70 Plaid, matches heavy duty ... JB-PLD-HD  
64-73 Black ..... JB-FM-BK  
64-73 Plaid (matches standard duty) ..... JB-FM-PLD  
64-73 Speckled ..... JB-FM-SPK

**JUMPER CABLE BAG**



Nice storage device to hold jumper cables, protects cables and trunk interior. Matches standard duty.

**Jumper Cable Bag**  
64-73 Black ..... BC-BK  
64-73 Plaid ..... BC-PLD  
64-73 Speckled ..... BC-SPK

**LARGE LUGGAGE TOTE BAG**



Heavy duty vinyl sewn storage bag. Carry handles with large zipper opening.

Available in all Black, Plaid or Speckled. Matches standard duty. Large tote bags are 21"x9"x9".

**Luggage Tote Bag, Large**  
64-73 Black, with emblem \* ..... TB-FM-BK-E  
64-73 Black, no emblem ..... TB-L-BK-NE  
64-73 Plaid, with emblem \* ..... TB-FM-L-PLD  
64-73 Plaid, no emblem ..... TB-L-PLD-NE  
64-73 Speckled, with emblem \* ... TB-FM-L-SPK  
64-73 Speckled, no emblem ..... TB-L-SPK-NE

**SMALL LUGGAGE TOTE BAG**



There is a full line of Trunk accessories to match our trunk mats. All made with the

same high quality material in the U.S. Check out our tire covers, tote bags and booster cable bag. Small tote bags are 17"x8"x8".

**Luggage Tote Bag, Small**  
64-73 Black, with emblem \* ..... TB-FM-BK-ES  
64-73 Black, no emblem ..... TB-S-BK-NE  
64-73 Plaid, with emblem \* ..... TB-FM-S-PLD  
64-73 Plaid, no emblem ..... TB-S-PLD-NE  
64-73 Speckled, with emblem \* ... TB-FM-S-SPK  
64-73 Speckled, no emblem ..... TB-S-SPK-NE

**WE PROUDLY FEATURE AUTHENTIC MUSTANG REPRODUCTIONS FROM SCOTT DRAKE ENTERPRISES!**





**TOOL KIT BAG**



Vinyl storage for common emergency tools, inside has felt lining. Matches standard duty.

**Tool Kit Bag**

- 64-73 Plaid .....TK-FM-PLD
- 64-73 Speckled .....TK-FM-SPK

**FILLER BOARDS**

**TAIL LIGHT FILLER BOARD**



Fits into the trunk compartment and protects the tail lamp housings. Made from original type black oil paper board.

**Tail Light Filler Board**

- 68 Shelby and California Special .....  
S8MS-65403A25-A
- 69-70 Shelby .....S9MS-65403A25-A

**TRUNK FILLER BOARD**

Mounts in left side of trunk to cover the hole between the quarter panel skin and the trunk floor. Made of heavy duty fiberboard or black chipboard.

**Trunk Filler Board**



- 64-66: Fiber board  
CSZZ-6511228-A



- 67-68: Black chipboard  
C7ZZ-6511228-A



- 69-70: Black chipboard  
C9ZZ-6511228-A

**TRUNK FILLER BOARD SCREWS**

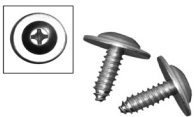

**Trunk Filler Board Screws**

- 64-67 .....379120-S

**GLOVE BOX AND TRUNK LOCKS**

**GLOVE BOX AND TRUNK LOCK**



This kit allows the use of one key for the glovebox and trunk lock. Original Ford option.

**Glove Box and Trunk Lock**

- 67-68 .....C6DZ-6506072-K
- 69-70 .....C9ZZ-6506072-K

**TRUNK LATCH**



Heavy duty steel stamped construction with a bright zinc plated finish.

**Trunk Latch**

- 64-66 .....C2OZ-6243200-B
- 67-73 .....C5AZ-6243200-A

**TRUNK LATCH STRIKER**



Exact detail made from heavy gauge steel. 65-66 available in silver zinc or bright chrome. 67-70 painted black.

**Trunk Latch Striker**

- 64-66 Zinc .....C40B-6243252
- 64-66 Chrome .....C40B-6243252-C
- 67-68 Black .....C7ZZ-6243252
- 69-70 Black .....C9ZZ-6243252

**PADS**

**SPARE TIRE JACK PAD**

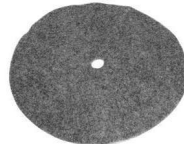

This extra thick felt pad protects rim from scratches and eliminates rattles caused by the jack.

**Spare Tire Jack Pad**

- 69-73 .....C9ZZ-17A092-A

**REAR SEAT DIVIDERS**

**REAR SEAT DIVIDER**



Separates the interior from the trunk space. Mounts behind the rear seat back rest. Reduces noise and insulates the interior

from trunk heat.

**Rear Seat Divider**

- 64-66 Coupe and Convertible ... C5ZZ-6545728
- 67-68 Coupe, gray felt ..... C7ZZ-6545728
- 67-68 Convertible ..... C7ZZ-7645728

**SPARE TIRE MOUNTING**

**SPACE SAVER MOUNTING BRACKET**



Kit that allows mounting a space saver tire in the trunk.

**Space Saver Mounting Bracket**

- 69-70 ..... C9ZZ-1424-K

**SPARE TIRE HOLD DOWN PLATE**

Mounting plate for your spare tire securely. Spare Tire Hold Down Plate



- 64-67: Black, standard wheels  
CSZZ-1424-A



- 64-67: Black, styled steel wheels  
CSZZ-1424-B



- 64-67: Chrome, styled steel wheels  
CSZZ-1424-C

**SPARE TIRE MOUNTING BOLT**

Exact copies of the bolts used by Ford. Zinc plated.

**Spare Tire Mounting Bolt**



- 64-65: Carriage bolt  
CSZZ-1448-B



- 65-67: Hook bolt  
C6OZ-1448-A

**Spare Tire Mounting Bolt**



69-73: Hook bolt, 1/2 inch - 13 x 10  
3/4 inches long  
C9Z-1448-B

**SPARE TIRE MOUNTING KIT**

Complete hardware kit to replace the factory mounting pieces. Includes correct cadmium plated wing nut, zinc plated mounting bolt, and painted hold-down plate with correct tabs. Exact reproductions of the originals.  
**Spare Tire Mounting Kit**



64-65: Carriage bolt  
C4Z-14244862-K



65-67: Hook bolt  
CSZ-14244862-K

**SPARE TIRE WING NUT**



Spare tire wingnut. Nice copies of the originals. Zinc plated like originals for extra corrosion protection.

**Spare Tire Wing Nut**

64-67 Zinc .....B9AZ-1462-A  
68-73 Zinc .....C8AZ-1462-B

**TRUNK CARPET**

**TRUNK CARPET KIT**



This kit includes everything to carpet the entire trunk area and is made of 100% nylon. All edges are bound to keep the

carpet from fraying. The side panels are made with fiberboard to make a clean professional installation.

**Trunk Carpet Kit**

65-66 Coupe, black .....TMK-CP-65-BK  
65-66 Fastback, black .....TMK-FB-65-BK  
67-68 Coupe, black .....TMK-CP-67-BK  
67-68 Fastback, black .....TMK-FB-67-BK  
70 Fastback, Black .....TMK-FB-70-BK

**TRUNK MATS & SPARE TIRE COVERS**

**HEAVY DUTY SPARE TIRE COVER**



Available in Plaid or Speckled patterns. Specially manufactured to match patterns on the "Heavy Duty Trunk

Mat". Thick vinyl construction.

**Heavy Duty Spare Tire Cover**

64-70 Plaid, 14 inch .....TC-PLD-14  
64-70 Plaid, 15 inch .....TC-PLD-15  
64-70 Speckled, 14 inch .....TC-SPK-14  
64-70 Speckled, 15 inch .....TC-SPK-15

**HEAVY DUTY TRUNK MAT**



Incredibly tough rubber-like mats made to our specifications. Just like the original Ford mats. Much more durable than

felt-backed vinyl mats. Formed to fit trunk floor. Fits coupes and convertibles with no trimming. Fastback installations require slight trimming.

**Heavy Duty Trunk Mat**

64-66 Plaid .....C5Z-6545456CAB  
65-68 Plaid .....C7Z-6545456CAB  
69-70 Speckled .....C9Z-6545456CAB  
71-73 Plaid, heavy duty .... D1Z-6545456CAB

**STANDARD DUTY SPARE TIRE COVER**



Available in Black, Plaid or Speckled. Sewn vinyl construction.

**Standard Duty Spare Tire Cover**

64-73 Black, 14 inch ..... TC-BLK-14V  
64-73 Black, 15 inch ..... TC-BLK-15V  
69-73 Space saver, black ..... TC-BLK-SS  
64-73 Plaid, 13 inch .....TC-PLD-13V  
64-73 Plaid, 14 inch .....TC-PLD-14V  
64-73 Plaid, 15 inch .....TC-PLD-15V  
64-73 Speckled, 13 inch ..... TC-SPK-13V  
64-73 Speckled, 14 inch .....TC-SPK-14V  
64-73 Speckled, 15 inch ..... TC-SPK-15V

**STANDARD DUTY TRUNK MAT**

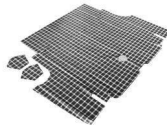

These precision cut mats are manufactured in the U.S. using the most correct material available. They fit perfectly. In addition,

they are printed with the correct plaid or speckle print. Felt backed.

**Standard Duty Trunk Mat**

65-66 Coupe and Convertible, plaid .....  
TM-FM-CPCV-65P

**Standard Duty Trunk Mat**

65-66 Coupe and Convertible, speckled .....  
TM-FM-CPCV-65-S  
65-66 Fastback, plaid ..... TM-FM-FB-65-P  
65-66 Fastback, speckled ..... TM-FM-FB-65-S  
67-68 Coupe and Convertible, plaid .....  
TM-FM-CPCV-67P  
67-68 Coupe and Convertible, speckled .....  
TM-FM-CPCV-67-S  
67-68 Fastback, plaid ..... TM-FM-FB-67-P  
67-68 Fastback, speckled ..... TM-FM-FB-67-S  
69-70 Coupe and Convertible, plaid .....  
TM-FM-CPCV-69P  
69-70 Coupe and Convertible, speckled .....  
TM-FM-CPCV-69-S  
69-70 Fastback, plaid ..... TM-FM-FB-69-P  
69-70 Fastback, speckled ..... TM-FM-FB-69-S  
71-73 Coupe and Convertible, plaid .....  
TM-FM-CPCV-71P  
71-73 Coupe and Convertible, speckled .....  
TM-FM-CPCV-71-S  
71-73 Fastback, plaid ..... TM-FM-FB-71-P  
71-73 Fastback, speckled ..... TM-FM-FB-71-S

**BURTEX TRUNK MAT**

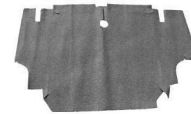

Original type construction Burtex. We found the best Burtex manufacturer in the country. Excellent fit. Order our Heavy

Duty Tire Covers for best match.

**Trunk Mat, Burtex**

64-68 Coupe and Convertible, speckled .....  
CSZ-6545456-B  
65-67 Fastback, speckled ..... CSZ-6345456-B  
67 Fastback, plaid ..... C7Z-6345456-B  
67 Coupe and Convertible, plaid .....  
C7Z-6545456-B  
68 Fastback, speckled ..... C8Z-6345456-B  
69-70 Coupe and Convertible, speckled .....  
C9Z-6545456-B  
71-73 Fastback, speckled ..... D1Z-6345456-B

**TRUNK RELEASES**

**TRUNK RELEASE**



High quality chrome with improved cable. Includes chrome base, lever cable, and all mounting hardware.

**Note: 67-70 release only**

**works on cars that come factory equipped with this option.**

**All others refer to electronic version.**

**Trunk Release**

64-66 All .....C4AZ-62432A00-A

**WE PROUDLY FEATURE AUTHENTIC MUSTANG REPRODUCTIONS FROM SCOTT DRAKE ENTERPRISES!**



**Trunk Release**

67-70 Factory equipped only .....  
C7AZ-62432A00-A

**ELECTRONIC TRUNK RELEASE**



We combined the classic look of the original remote trunk release with a chrome release lever and a strong electric

solenoid driven latch with a modern micro switch release. Now, with a light finger pull the trunk lid opens. No cables to stretch or corrode. Simple 30 minute installation with no modifications to the car. All mounting hardware and connectors are included. Fits Coupe, Fastback and Convertible.

**Trunk Release, Electronic**

64-66 .....C5AZ-6243200-EL  
69-70 only utilizes 2 of 3 mounting bolts.....  
C7AZ-6243200-EL

**WIRELESS TRUNK RELEASE**



This kit is an upgrade to our Electronic Trunk Release. Kit includes two wireless remotes that open your trunk with the push of a

button. Check for availability.

**Trunk Release, Wireless**

65-70 ..... CSZZ-6243200-WR

**TRUNK UNDERLAYMENTS**

**TRUNK UNDERLAYMENT**



Installs over fuel tank and under trunk mat. Helps to reduce trunk noise and protect top of fuel tank. Thick rubber material.

65-68 Trunk.....UL-5

**WHEELS**

**BEARINGS AND RACES**

**BRAKE HUB GREASE CAP**



Stamped steel with gold dichromate finish.

**Brake Hub Grease Cap**

64-66 6 cylinder .....C3DZ-1131-A

**Brake Hub Grease Cap**

64-69 8 cylinder ..... B5A-1131-A

**FRONT WHEEL BEARING AND RACE**



U.S. made quality bearings.

**Front Wheel Bearing and Race**

64-66 Inner, 6 cylinder, drum brakes .....  
CSZZ-1201-A

64-66 Outer, 6 cylinder, drum brakes .....  
CSZZ-1216-A

64-69 Inner, V8 ..... B5A-1201-A

64-69 Outer, V8 ..... B5A-1216-A

70-73 Inner ..... D0ZZ-1201-A

70-73 Outer ..... D0ZZ-1216-A

**REAR WHEEL BEARING**



High quality part made in the U.S.A.

**Rear Wheel Bearing**

64-73 V8, 8 & 9 inch rear end, 28 spline .....  
CSZZ-1225-A

65-70 6 cylinder, 24 spline ..... CSZZ-1225-B

**LUG NUTS AND WRENCHES**

**LUG NUT**

Multiple styles of lugnuts are available to finish off the look of your wheels.

**Lug Nut**



64-73: Standard  
COAZ-1012-A



65-67: Styled steel, show quality, chrome  
CSZZ-1012-A



69-73: Magnum 500, Show quality, chrome  
C9ZZ-1012-B

**LOCKING LUG NUT KIT**



Set includes 16 chrome lug nuts, 4 locking chrome lug nuts, key lock and 4 chrome valve stems. These lug nuts match our Classic

Wheels (S1MS-1007- part numbers).

**Lug Nut Kit, Locking**

64-73 ..... S1MS-1007-LUGKT

**WHEEL LOCK**



Protect your expensive rims and tires from theft. Our locks are made to resemble factory lugnuts for a cleaner appearance.

This kit includes four chrome, keyed lugnuts and matching key.

**Wheel Lock**

64-73 ..... CSZZ-1012-LOCK

**SEALS, SPACERS, & VALVE STEMS**

**VALVE STEM CAPS**



Chrome hex shaped valve stem caps with various logos.

**Valve Stem Caps**

64-73 Tiffany\* .....ACC-5030181

64-73 GT\* .....ACC-5030670

64-73 Cobra\* .....ACC-5033205

64-73 Blue oval logo\* .....ACC-5033260

64-73 Tri-bar\* .....ACC-5033270

**SHORT CHROME VALVE STEMS**



**Valve Stems, Short Chrome**

64-73 Set of 4 ..... ACC-CVS

**FRONT WHEEL GREASE SEAL**



Made in the U.S. to ensure high quality and reliability.

**Wheel Grease Seal, Front**

64-70 V8 .....B5AZ-1190-A

65-66 6 cylinder, drum brakes .... CSZZ-1190-A

69 Boss disc brakes ..... C9ZZ-1190-A

### REAR AXLE WHEEL SEAL

Made in the U.S. to ensure high quality and reliability.



#### Wheel Seal, Rear Axle

64-66 V8, 8 inch rear end, 28 spline .....

C5ZZ-1177-A

64-66 6 cylinder ..... C5ZZ-1177-B

65-73 9 inch rear end, 31 spline ...C5ZZ-1177-C

67-73 V8, 8 & 9 inch rear end, 28 spline .....

C7ZZ-1177-A

### WHEEL SPACER

Aluminum spacer to off-set custom wheels. This hard to find thin spacer is sometimes required to clear upper control

arm when running oversized tires on our style steel rim. Does not require longer studs as recommended with more common 1/4" spacers.

#### Wheel Spacer

65-73 1/8 inch thick .....SP601-S



## WHEEL

### CLASSIC WHEEL



Chrome



Charcoal

Scott Drake is proud to offer these licensed reproductions\* of this classic 1960's wheel design, at an affordable price. Built with today's modern technology, these wheels are available in Chrome, Polished or Charcoal and all come with Chrome Logoed Cap. Available in sizes from 15x6 to 17x8. Lug nuts sold separately under part # S1MS-1007-LUGKT which includes 16 Chrome lug nuts, 4 locking Chrome lug Nuts, Key Lock and 4 Chrome Valve Stems. \*The wheel designs are

registered trade marks of "AMERICAN RACING EQUIPMENT, LLC" Licensed to "REV WHEEL, L.L.C."

#### Wheel, Classic

64-73 Charcoal, 15 x 6 with 3.5" Backspace .....  
S1MS-1007-156

64-73 Chrome, 15 x 6 with 3.5" Backspace .....  
S1MS-1007-156C

64-73 Polished, 15 x 6 with 3.5" Backspace .....  
S1MS-1007-156P

64-73 Charcoal, 15 x 7 with 4" Backspace .....  
S1MS-1007-157

64-73 Chrome, 15 x 7 with 4" Backspace .....  
S1MS-1007-157C

64-73 Polished, 15 x 7 with 4" Backspace .....  
S1MS-1007-157P

64-73 Charcoal, 15 x 8 with 4.5" Backspace .....  
S1MS-1007-158

64-73 Chrome, 15 x 8 with 4.5" Backspace .....  
S1MS-1007-158C

64-73 Polished, 15 x 8 with 4.5" Backspace .....  
S1MS-1007-158P

64-73 Chrome, 16 x 7 with 4" Backspace .....  
S1MS-1007-167C

64-73 Chrome, 16 x 8 with 4.5" Backspace .....  
S1MS-1007-168C

64-73 Charcoal, 17 x 7 with 4" Backspace .....  
S1MS-1007-177

64-73 Chrome, 17 x 7 with 4" Backspace .....  
S1MS-1007-177C

64-73 Polished, 17 x 7 with 4" Backspace .....  
S1MS-1007-177P

64-73 Charcoal, 17 x 8 with 4.5" Backspace .....  
S1MS-1007-1784

64-73 Charcoal, 17 x 8 with 5" Backspace .....  
S1MS-1007-1785

64-73 Chrome, 17 x 8 with 4.5" Backspace .....  
S1MS-1007-178C4

64-73 Chrome, 17 x 8 with 5" Backspace .....  
S1MS-1007-178C5

64-73 Polished, 17 x 8 with 4.5" Backspace .....  
S1MS-1007-178P4

64-73 Polished, 17 x 8 with 5" Backspace .....  
S1MS-1007-178P5

### COBRA-STYLE WHEEL



These wheels are real head turners. Available in all chrome or polished with charcoal inserts to match your vehicle. 4

1/2" backspacing. Lugnuts sold separately.

#### Wheel, Cobra-style

65-73 Chrome, 17 inch x 8 inch ... R-1007-340C

65-73 Charcoal, 17 inch x 8 inch .R-1007-340SC

### MAGNUM 500 WHEEL

Does not include center cap. Beautiful chrome plating. Concours correct lugnuts sold separately.



#### Wheel, Magnum 500

69 15 inch x 7 inch, 2 inch center hole .....

C9ZZ-1007-B

69-73 14 inch by 7 inch, 2 1/8 inch center hole .

D1ZZ-1007-B

69-73 15 inch x 7 inch, 2 1/8 inch center hole ...

D1ZZ-1007-A

69-73 15 inch x 8 inch, 2 1/8 inch center hole ...

D1ZZ-1007-C

### SHELBY-STYLE WHEEL

17" Shelby 10-Spoke Wheels for early Mustangs! These wheels feature cast and machined-textured surfaces, which provide a beautiful contrast under a clear-coat, protective finish. Aftermarket center caps included.

#### Wheel, Shelby-style



64-73: 15 inch x 7 inch

S7MS-1007-A

### STYLED STEEL WHEEL



These Styled Steel wheels are the best on the market. Features include: " Precise assembly to ensure a true and balanceable

rim " Triple chrome plating " Attractive and informative double wall shipping boxes " Correct charcoal painted recesses baked on for durability " Simulated rivets on stock sizes for concours judging " Correct clearance for original 1965-67 4 piston disc brake calipers.

#### Wheel, Styled Steel

65 14 inch x 5 inch, chrome, charcoal inner .

C5ZZ-1007-A

64 14 inch x 5 inch, chrome, argent inner ...

C5ZZ-1007-ARG

65-67 14 inch x 6 inch, chrome ... C5ZZ-1007-D

65-67 14 inch x 7 inch, chrome ... C5ZZ-1007-B

65-67 15 inch x 7 inch, chrome .... C5ZZ-1007-C

66 14 inch x 5 inch, black rim . C6ZZ-1007-A

67 14 inch x 5 1/2 inch, black rim .....

C7ZZ-1007-A

**WE PROUDLY FEATURE AUTHENTIC MUSTANG REPRODUCTIONS FROM SCOTT DRAKE ENTERPRISES!**



**68-69 STYLED STEEL WHEEL**



These Styled Steel wheels are the best on the market.

**Wheel, Vintage 45**

- 68-69 14 inch x 6 inch, black rim ... C80Z-1007-A
- 68-69 14 inch x 6 inch, chrome ... C80Z-1007-B
- 68-69 14 inch x 7 inch, chrome ... C80Z-1007-C
- 68-69 15 inch x 7 inch, chrome ... C80Z-1007-D

**VINTAGE 45 WHEEL**



Vintage 45 wheels feature media blasted/machine, curved spokes. This line of classic alloy wheels are engineered &

designed with yesteryear's performance car in mind.

**Wheel, Vintage 45**

- 64-73 17 inch x 8 inch ..... V45-17X8

**WHEEL ACCENTS**

**STYLED STEEL WHEEL ACCENT**



Features include a bright-chrome finish and simple snap-in installation. These were a rare option offered by Ford. These wheel

accents really dress up argent or body-color painted rims! 50 piece set does 4 wheels.

**Styled Steel Wheel Accent**

- 68-69 ..... C9ZZ-1A079-A

**WHEEL HUB CAPS, COVERS, & BEAUTY RINGS**

**BILLET HUB CAP**



High quality billet to give your Torq Thrust or Vintage wheels a finishing

touch. Also available plain with no logo. Hole spacing on vintage caps is 2-1/16" and on Torq Thrust spacing is 2-1/4".

**Hub Cap, Billet**

- 64-73 Cobra logo, Torq Thrust D wheel, set of 4 \*  
B-1130-COBRA-T
- 64-73 Cobra logo, vintage wheel, set of 4 \*  
B-1130-COBRA-V

**Hub Cap, Billet**

- 64-73 GT logo, Torq Thrust D wheel, set of 4 .....  
B-1130-GT-T
- 64-73 GT logo, vintage wheel, set of 4 .....  
B-1130-GTV
- 64-73 Horse logo, Torq Thrust D wheel, set of 4 \*  
B-1130-H-T
- 64-73 Horse logo, vintage wheel, set of 4 \* .....  
B-1130-HV
- 64-73 No logo, Torq Thrust D wheel, set of 4 .....  
B-1130-P-T
- 64-73 No logo, vintage wheel, set of 4 .....  
B-1130-PV

**SHELBY HUB CAP**



Our hub caps feature perfect detail and the correct red accent color. Our design is time tested and guaranteed not to separate from the wheel while driving.

**Hub Cap, Shelby**



- 65-66: G.T.350 cobra logo<sup>§</sup>  
S2MS-1130-B



- 66-67: CS logo, fits 10 spoke Shelby wheel<sup>§</sup>  
S2MS-1130-C



- 69-70: Cobra logo<sup>§</sup>  
S9MS-1130-D

**KNOCK OFF HUB CAP**

Die cast construction with show car chrome.

**Knock Off Hub Cap**



- 65  
CSZZ-1141-A



- 66  
C6ZZ-1141-A

**KNOCK OFF HUB CAP EMBLEM**



These are the center emblems for our knock off hub caps.

**Knock Off Hub Cap Emblem**



- 65: Spinner, standard\*  
CSZZ-1141-E

**Knock Off Hub Cap Emblem**



- 66: Spinner, standard\*  
C6ZZ-1141-E

**MAGNUM HUB CAP**



These beautiful hub caps feature our high quality chrome bezels. Designed to fit Magnum 500 wheels.

**Magnum Hub Cap**



- 69: Fits 2 inch center hole\*  
C9ZZ-1130-E



- 69-70: 2 1/8" hole, 0.66" tall\*  
D0ZZ-1130-A



- 69-73: Spinner (fits Magnum Wheels)\*  
D1ZZ-1141-A



- 71-73: Fits 2 1/8 inch hole, 1" tall\*  
D1ZZ-1130-GR

**STYLED STEEL HUB CAP**



Scott Drake Mustang Hub Caps feature show-quality chrome plating, perfectly detailed lenses, and correct accent colored backgrounds. Our new and improved retaining system now makes them easier to install and prevents them from falling off or being stolen. These are the finest reproductions on the market at very competitive prices. Choose original colors: Red for 64-66 and blue for 67, or customize your car with a color better suited for your Mustang. We offer red, blue, and black for all years.

**Styled Steel Hub Cap**



- 65-66: Black\*  
CSZZ-1130-BK



- 65-66: Black, set of 4\*  
CSZZ-1130-WB



- 65-66: Blue\*  
CSZZ-1130-BL

**Styled Steel Hub Cap**



65-66: Blue, set of 4\*  
CSZZ-1130-WBL



65-66: Red\*  
CSZZ-1130-W



65-66: Red, set of 4\*  
CSZZ-1130-WR



67: Black\*  
C7ZZ-1130-B



67: Black, set of 4\*  
C7ZZ-1130-BK



67: Blue\*  
C7ZZ-1130-A



67: Blue, set of 4\*  
C7ZZ-1130-AK



67: Red\*  
C7ZZ-1130-R



67: Red, set of 4\*  
C7ZZ-1130-RK



68-69: GT  
C80Z-1130-C



68-69: Plain, no logo  
C80Z-1130-G

**STYLED STEEL HUB CAP EMBLEM**

**Styled Steel Hub Cap Emblem**



68-69: GT  
C80Z-1141-A

**STYLED STEEL WHEEL COVER**



Gives the illusion of real styled steel wheels at one third of the price. Constructed from heavy duty A.B.S. plastic. Also features

correct charcoal painted recessed area's and chrome simulated lugnuts. Now even 6 cylinders can have an 8 cylinder look. Center cap not included.

**Styled Steel Wheel Cover**

64-67 14 inch, set of 4 .....CSZZ-1007-HCS  
65-67 14 inch .....CSZZ-1007-HC

**STYLED STEEL WHEEL COVER HUB CAP**



These caps are gorgeous. Designed to fit our plastic styled steel wheel covers.



**Styled Steel Wheel Cover Hub Cap**

64-66 Black, set of 4\* .....CSZZ-1130-BKL  
65-66 Red, each\* .....CSZZ-1130-WL

**WHEEL BEAUTY RING**



Great reproductions of the original parts. Polished stainless steel.

**Wheel Beauty Ring**

66 Original style .....C6ZZ-1210-AR  
66 Original style, set of 4 .....C6ZZ-1210-AS  
67 Original style .....C7ZZ-1210-AR  
67 Original style, set of 4 .....C7ZZ-1210-AS

**WHEEL COVER**

Center emblem not included. Stock replacement wheelcovers. Can be modified to accept knock off spinners.

**Wheel Cover**



65: 14 inch  
CSZZ-1130-J



66: 14 inch  
C6ZZ-1130-A

**WHEEL COVER EMBLEM**



Fits our standard wheel covers.

**Wheel Cover Emblem**



65\*  
CSZZ-11C30



66\*  
C6ZZ-11C30



67\*  
C7ZZ-11C30

**WIRE SPOKE CENTER CAP**



Fits wire spoked wheel covers.



**Wire Spoke Center Cap**

65-66 Spinner, blue, Ford crest\* ...CSAZ-1141-A

**WIRE SPOKE WHEEL COVER**



Spinner and emblem sold separately.

**Wire Spoke Wheel Cover**

65-67 .....CSAZ-1130

**WINDOWS**

**BACK GLASS**

**COUPE BACK GLASS**

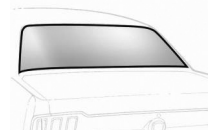

Coupe back glass is available in clear, factory green tinted, or a new "smoke" version which resembles a modern black tint.

**Back Glass, Coupe**

64-68 Clear .....CSZZ-6542006-C  
64-68 Smoke .....CSZZ-6542006-S  
64-68 Tinted .....CSZZ-6542006-T  
69-70 Clear .....C9ZZ-6542006-C  
69-70 Smoke .....C9ZZ-6542006-S

Wheel

**WE PROUDLY FEATURE AUTHENTIC MUSTANG REPRODUCTIONS FROM SCOTT DRAKE ENTERPRISES!**



221

**Back Glass, Coupe**

69-70 Tinted .....C9ZZ-6542006-T

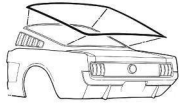
**FASTBACK BACK GLASS**

Fastback back glass is available in clear, factory green tinted, or a new "smoke" version which resembles a modern black tint.

**Back Glass, Fastback**

65-66 Clear .....C5ZZ-6342006-C  
 65-66 Smoke .....C5ZZ-6342006-S  
 65-66 Tinted .....C5ZZ-6342006-T  
 67-68 Clear .....C7ZZ-6342006-C  
 67-68 Smoke .....C7ZZ-6342006-S  
 67-68 Tinted .....C7ZZ-6342006-T  
 69-70 Clear .....C9ZZ-6342006-C  
 69-70 Smoke .....C9ZZ-6342006-S  
 69-70 Tinted .....C9ZZ-6342006-T

**DOOR GLASS****CONVERTIBLE DOOR GLASS**

Convertible door glass is available in clear, factory green tinted, or a new "smoke" version which resembles a modern black tint.

Glass only.

**Door Glass, Convertible**

64-66 Right hand, clear .....C5ZZ-7621410-C  
 64-66 Right hand, smoke .....C5ZZ-7621410-S  
 64-66 Right hand, tinted .....C5ZZ-7621410-T  
 64-66 Left hand, clear .....C5ZZ-7621411-C  
 64-66 Left hand, smoke .....C5ZZ-7621411-S  
 64-66 Left hand, tinted .....C5ZZ-7621411-T  
 67-68 Right hand, clear .....C7ZZ-7621410-C  
 67-68 Right hand, smoke .....C7ZZ-7621410-S  
 67-68 Right hand, tinted .....C7ZZ-7621410-T  
 67-68 Left hand, clear .....C7ZZ-7621411-C  
 67-68 Left hand, smoke .....C7ZZ-7621411-S  
 67-68 Left hand, tinted .....C7ZZ-7621411-T  
 70 Right hand, clear .....D0ZZ-7621410-C  
 70 Tinted, RH .....D0ZZ-7621410-T  
 70 Left hand, clear .....D0ZZ-7621411-C  
 70 Tinted, LH .....D0ZZ-7621411-T

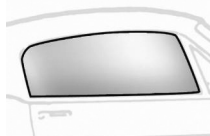
**COUPE DOOR GLASS**

Coupe door glass is available in clear, factory green tinted, or a new "smoke" version which resembles a modern black tint.

Glass only. *Note: 69 is "glue in" and 70 is "bolt in"***version.****Door Glass, Coupe**

64-66 Right hand, clear .....C5ZZ-6521410-C  
 64-66 Right hand, smoke .....C5ZZ-6521410-S  
 64-66 Right hand, tinted .....C5ZZ-6521410-T  
 64-66 Left hand, clear .....C5ZZ-6521411-C  
 64-66 Left hand, smoke .....C5ZZ-6521411-S  
 64-66 Left hand, tinted .....C5ZZ-6521411-T  
 67-68 Right hand, clear .....C7ZZ-6521410-C  
 67-68 Right hand, smoke .....C7ZZ-6521410-S  
 67-68 Right hand, tinted .....C7ZZ-6521410-T  
 67-68 Left hand, clear .....C7ZZ-6521411-C  
 67-68 Left hand, smoke .....C7ZZ-6521411-S  
 67-68 Left hand, tinted .....C7ZZ-6521411-T  
 69 Right hand, clear .....C9ZZ-6521410-C  
 69 Right hand, smoke .....C9ZZ-6521410-S  
 69 Right hand, tinted .....C9ZZ-6521410-T  
 69 Left hand, clear .....C9ZZ-6521411-C  
 69 Left hand, smoke .....C9ZZ-6521411-S  
 69 Left hand, tinted .....C9ZZ-6521411-T  
 70 Right hand, clear .....D0ZZ-6521410-C  
 70 Right hand, smoke .....D0ZZ-6521410-S  
 70 Right hand, tinted .....D0ZZ-6521410-T  
 70 Left hand, clear .....D0ZZ-6521411-C  
 70 Left hand, smoke .....D0ZZ-6521411-S  
 70 Left hand, tinted .....D0ZZ-6521411-T

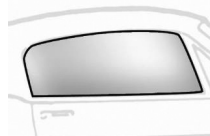
**FASTBACK DOOR GLASS**

Fastback door glass is available in clear, factory green tinted, or a new "smoke" version which resembles a modern black tint.

Glass only. *Note: 69 is "glue in" and 70 is "bolt in"***version.****Door Glass, Fastback**

65-66 Right hand, clear .....C5ZZ-6321410-C  
 65-66 Right hand, smoke .....C5ZZ-6321410-S  
 65-66 Right hand, tinted .....C5ZZ-6321410-T  
 65-66 Left hand, clear .....C5ZZ-6321411-C  
 65-66 Left hand, smoke .....C5ZZ-6321411-S  
 65-66 Left hand, tinted .....C5ZZ-6321411-T  
 67-68 Right hand, clear .....C7ZZ-6321410-C  
 67-68 Right hand, smoke .....C7ZZ-6321410-S  
 67-68 Right hand, tinted .....C7ZZ-6321410-T  
 67-68 Left hand, clear .....C7ZZ-6321411-C  
 67-68 Left hand, smoke .....C7ZZ-6321411-S  
 67-68 Left hand, tinted .....C7ZZ-6321411-T  
 69 Right hand, clear .....C9ZZ-6321410-C  
 69 Right hand, smoke .....C9ZZ-6321410-S  
 69 Right hand, tinted .....C9ZZ-6321410-T  
 69 Left hand, clear .....C9ZZ-6321411-C  
 69 Left hand, smoke .....C9ZZ-6321411-S  
 69 Left hand, tinted .....C9ZZ-6321411-T  
 70 Right hand, clear .....D0ZZ-6321410-C  
 70 Right hand, smoke .....D0ZZ-6321410-S  
 70 Right hand, tinted .....D0ZZ-6321410-T  
 70 Left hand, clear .....D0ZZ-6321411-C  
 70 Left hand, smoke .....D0ZZ-6321411-S

**Door Glass, Fastback**

70 Left hand, tinted .....D0ZZ-6321411-T  
 71-73 Right hand, clear .....D1ZZ-6321410-C  
 71-73 Right hand, smoke .....D1ZZ-6321410-S  
 71-73 Right hand, tinted .....D1ZZ-6321410-T  
 71-73 Left hand, clear .....D1ZZ-6321411-C  
 71-73 Left hand, smoke .....D1ZZ-6321411-S  
 71-73 Left hand, tinted .....D1ZZ-6321411-T

**DOOR GLASS ASSEMBLY**

This door glass includes the frame, glass run and mounting bracket. Available in clear glass only. For replacement

glass only, see windows section.

**Door Glass Assembly**

67-68 Fastback, left hand ....C7ZZ-6321410-KL  
 67-68 Fastback, right hand .C7ZZ-6321410-KR  
 67-68 Coupe, left hand .....C7ZZ-6521410-KL  
 67-68 Coupe, right hand .....C7ZZ-6521410-KR  
 67-68 Convertible, left hand .C7ZZ-7621410-KL  
 67-68 Convertible, right hand .....C7ZZ-7621410-KR

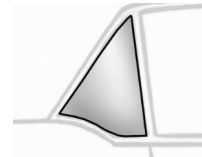
**QUARTER GLASS****CONVERTIBLE QUARTER GLASS**

Convertible quarter glass is available in clear, factory green tinted, or a new "smoke" version which resembles a modern

black tint.

**Quarter Glass, Convertible**

64-66 Right hand, clear .....C5ZZ-7629710-C  
 64-66 Right hand, smoke .....C5ZZ-7629710-S  
 64-66 Right hand, tinted .....C5ZZ-7629710-T  
 64-66 Left hand, clear .....C5ZZ-7629711-C  
 64-66 Left hand, smoke .....C5ZZ-7629711-S  
 64-66 Left hand, tinted .....C5ZZ-7629711-T  
 67-68 Right hand, clear .....C7ZZ-7629710-C  
 67-68 Right hand, smoke .....C7ZZ-7629710-S  
 67-68 Right hand, tinted .....C7ZZ-7629710-T  
 67-68 Left hand, clear .....C7ZZ-7629711-C  
 67-68 Left hand, smoke .....C7ZZ-7629711-S  
 67-68 Left hand, tinted .....C7ZZ-7629711-T  
 69 Right hand, clear .....C9ZZ-6529710-C  
 69 Right hand, smoke .....C9ZZ-6529710-S  
 69 Right hand, tinted .....C9ZZ-6529710-T  
 69 Left hand, clear .....C9ZZ-6529711-C  
 69 Left hand, smoke .....C9ZZ-6529711-S  
 69 Left hand, tinted .....C9ZZ-6529711-T  
 70 Right hand, clear .....D0ZZ-6529710-C  
 70 Right hand, smoke .....D0ZZ-6529710-S

**Quarter Glass, Convertible**

- 70 Right hand, tinted ..... D0ZZ-6529710-T
- 70 Left hand, clear ..... D0ZZ-6529711-C
- 70 Left hand, smoke ..... D0ZZ-6529711-S
- 70 Left hand, tinted ..... D0ZZ-6529711-T

**COUPE QUARTER GLASS**

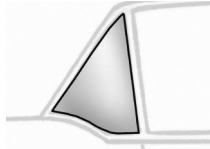

Coupe quarter glass is available in clear, factory green tinted, or a new "smoke" version which resembles a modern black tint.

**Quarter Glass, Coupe**

- 64-66 Right hand, clear ..... CSZZ-6529710-C
- 64-66 Right hand, smoke ..... CSZZ-6529710-S
- 64-66 Right hand, tinted ..... CSZZ-6529710-T
- 64-66 Left hand, clear ..... CSZZ-6529711-C
- 64-66 Left hand, smoke ..... CSZZ-6529711-S
- 64-66 Left hand, tinted ..... CSZZ-6529711-T
- 67-68 Right hand, clear ..... C7ZZ-6529710-C
- 67-68 Right hand, smoke ..... C7ZZ-6529710-S
- 67-68 Right hand, tinted ..... C7ZZ-6529710-T
- 67-68 Left hand, clear ..... C7ZZ-6529711-C
- 67-68 Left hand, smoke ..... C7ZZ-6529711-S
- 67-68 Left hand, tinted ..... C7ZZ-6529711-T
- 69 Right hand, clear ..... C9ZZ-6529710-C
- 69 Right hand, smoke ..... C9ZZ-6529710-S
- 69 Right hand, tinted ..... C9ZZ-6529710-T
- 69 Left hand, clear ..... C9ZZ-6529711-C
- 69 Left hand, smoke ..... C9ZZ-6529711-S
- 69 Left hand, tinted ..... C9ZZ-6529711-T
- 70 Right hand, clear ..... D0ZZ-6529710-C
- 70 Right hand, smoke ..... D0ZZ-6529710-S
- 70 Right hand, tinted ..... D0ZZ-6529710-T
- 70 Left hand, clear ..... D0ZZ-6529711-C
- 70 Left hand, smoke ..... D0ZZ-6529711-S
- 70 Left hand, tinted ..... D0ZZ-6529711-T

**FASTBACK QUARTER GLASS**



Fastback quarter glass is available in clear, factory green tinted, or a new "smoke" version which resembles a modern black tint.

**Quarter Glass, Fastback**

- 69-70 Right hand, clear ..... C9ZZ-6329710-C
- 69-70 Right hand, smoke ..... C9ZZ-6329710-S
- 69-70 Right hand, tinted ..... C9ZZ-6329710-T
- 69-70 Left hand, clear ..... C9ZZ-6329711-C
- 69-70 Left hand, smoke ..... C9ZZ-6329711-S
- 69-70 Left hand, tinted ..... C9ZZ-6329711-T
- 71-73 Right hand, clear ..... D1ZZ-6329710-C
- 71-73 Right hand, smoke ..... D1ZZ-6329710-S
- 71-73 Right hand, tinted ..... D1ZZ-6329710-T
- 71-73 Left hand, clear ..... D1ZZ-6329711-C
- 71-73 Left hand, smoke ..... D1ZZ-6329711-S
- 71-73 Left hand, tinted ..... D1ZZ-6329711-T

**COUPE QUARTER GLASS ASSEMBLY**



Complete quarter window assembly for Mustang Coupes. Includes chrome plated die-cast frame, glass, seal and rollers.

**Quarter Glass Assembly, Coupe**

- 64-66 Right Hand, clear ..... CSZZ-6529958-CK
- 64-66 Right Hand, tinted ..... CSZZ-6529958-TK
- 64-66 Left Hand, clear ..... CSZZ-6529959-CK
- 64-66 Left Hand, tinted ..... CSZZ-6529959-TK

**FASTBACK QUARTER GLASS FRAME**

69-70 Fastback Quarter Glass Frame.



**Quarter Glass Frame, Fastback**

- 69-70 ..... C9ZZ-63302223

**FASTBACK QUARTER GLASS ASSEMBLY**



Quarter window assembly for Mustang Fastbacks.

**Quarter Glass Assembly, Fastback**

- 69-70 Right hand, clear ..... C9ZZ-6321410-K
- 69-70 Left hand, clear ..... C9ZZ-6321411-K

**VENT GLASS**

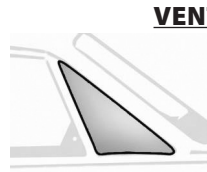

Vent glass is available in clear, factory green tinted, or a new "smoke" version which resembles a modern black tint. Fits convertible, coupe, and Fastback.

**Vent Glass**

- 64-68 Right hand, clear ..... CSZZ-6521412-C
- 64-68 Right hand, smoke ..... CSZZ-6521412-S
- 64-68 Right hand, tinted ..... CSZZ-6521412-T
- 64-68 Left hand, clear ..... CSZZ-6521413-C
- 64-68 Left hand, smoke ..... CSZZ-6521413-S
- 64-68 Left hand, tinted ..... CSZZ-6521413-T

**VENT WINDOW FRAME AND GLASS ASSEMBLY**



Complete vent and window assembly. Includes vent frame, vent glass, vent glass frame and pivot assembly, vent seals, and door glass run. 68 version will fit 67 cars it just has the the

wrong vent window handle.

**Vent Window Frame and Glass Assembly**

- 64-66 Right Hand, clear ..... C5ZZ-65222404CK
- 64-66 Right Hand, tinted ..... C5ZZ-65222404TK
- 64-66 Left Hand, clear ..... C5ZZ-65222405CK
- 64-66 Left Hand, tinted ..... C5ZZ-65222405TK
- 68 Right Hand, clear ..... C8ZZ-65222404CK
- 68 Right Hand, tinted ..... C8ZZ-65222404TK
- 68 Left Hand, clear ..... C8ZZ-65222405CK
- 68 Left Hand, tinted ..... C8ZZ-65222405TK

**VENT WINDOW GLASS FRAME AND GLASS**



Chrome plated vent window glass frame with pivot and glass. Will fit 1968, but comes with 1967 vent window handle attached.

**Vent Window Glass Frame and Glass**

- 67 Right Hand, clear ..... C7ZZ-6521608-CK
- 67 Right hand, tinted ..... C7ZZ-6521608-TK
- 67 Left hand, clear ..... C7ZZ-6521609-CK
- 67 Left hand, tinted ..... C7ZZ-6521609-TK

**WINDSHIELD GLASS**

**WINDSHIELD GLASS**

Nice replacement windshields without Ford logos.



**Windshield Glass**

- 65-68 All, clear ..... C6ZZ-6503100-C
- 65-68 All, tinted ..... C6ZZ-6503100-T
- 69-70 Fastback, clear ..... C9ZZ-6503100-C
- 69-70 Fastback, tinted ..... C9ZZ-6503100-T

**WIPERS**

**WASHER COMPONENTS**

**FORD LICENSED WINDSHIELD WASHER BAG**

\* Official Licensed Product High quality rubberized vinyl bag, with silk screened FoMoCo logo. An exact copy of the original unit.

**Windshield Washer Bag, Ford Licensed**



- 64-65: White FoMoCo, twist cap\* C1AZ-17618-EA

Windows

**WE PROUDLY FEATURE AUTHENTIC MUSTANG REPRODUCTIONS FROM SCOTT DRAKE ENTERPRISES!**





**Windshield Washer Bag, Ford Licensed**



66: White FoMoCo, flip cap\*  
C1AZ-17618-E



66-67: Gold Ford logo, twist cap\*  
C1AZ-17618-D



66-67: Gold Ford logo, flip cap  
C7Z-17618-DR

**WINDSHIELD WASHER HOSE CONNECTOR**



Injection molded high strength plastic connector for hoses leading to nozzles. Just like the factory pieces.

**Windshield Washer Hose Connector**

64-66	.....	COAB-17A601-A
67-70	.....	C7SZ-17A601-A
71-73	.....	D1ZZ-17A601-A

**WINDSHIELD WASHER HOSE KIT**



Made from high quality E.P.D.M. rubber with factory style ribbing along the length of each hose. Kits include proper

connector for each year. Hoses are cut to correct length.

**Windshield Washer Hose Kit**

64-66	.....	CSZZ-17601/5
67-68	.....	C7ZZ-17601/5
69-70	.....	C9ZZ-17601/5
71-73	.....	D1ZZ-17601/5

**FORD LICENSED, COMPLETE WINDSHIELD WASHER KIT**



Good looking and very complete. Kit includes washer bag, wiper hoses,

wiper nozzle's and windshield wiper spacer and nuts.

**Windshield Washer Kit, Ford Licensed, Complete**

64-65	*	.....	KIT-WIP-1
66	*	.....	KIT-WIP-2

**WINDSHIELD WASHER NOZZLE**

These are excellent reproductions of the original rubber-tipped and later metal-tipped nozzles. Bright cadmium finish for corrosion protection. Sold in pairs.

**Windshield Washer Nozzle**



64-65: Rubber tips  
C5ZZ-17603-D



66: Steel tips  
C5ZZ-17603-E



67: Copper/Black  
C7Z-17603-A



68: Copper/Black  
C7Z-17603-B



69  
C9ZZ-17603-A



70: Steel tips  
D0ZZ-17603-A

**WINDSHIELD WASHER NOZZLE TIP**

Molded rubber replacement tips.



**Windshield Washer Nozzle Tip**

64-65	Rubber	.....	C5AZ-17A602-B
-------	--------	-------	---------------

**WINDSHIELD WASHER PUMP**

Original style washer pumps made to last.

**Windshield Washer Pump**



64-65: 1 speed  
C4AZ-17664-A



65-66: 2 speed  
C5AZ-17664-A

**Windshield Washer Pump**



69-73: 2 speed  
E0AZ-17664-A

**WINDSHIELD WASHER PUMP HARNESS**

Supplies power to washer pump.



**Windshield Washer Pump Harness**

64-65	.....	CSZZ-17290-A	
66	1 speed	.....	C6ZZ-17290-A1
66	2 speed	.....	C6ZZ-17290-A2

**WINDSHIELD WASHER PUMP REPAIR**

Replacement for under-dash foot operated pump.



**Windshield Washer Pump Repair**

67-68	.....	C7ZZ-17664-RP
-------	-------	---------------

**FORD LICENSED WINDSHIELD WASHER RESERVOIR**

\* Blow Molding Plastic Features Exact Detail With FoMoCo logo.

**Windshield Washer Reservoir, Ford Licensed**



67-68 \*  
C70Z-17618-A



67-78: Reservoir without logo  
C70Z-17618-R



69-70: Reservoir\*  
C9ZZ-17618-A

**WINDSHIELD WASHER RESERVOIR BRACKET**

Stamped steel, painted black enamel.



**Windshield Washer Reservoir Bracket**

65-66	.....	C4AZ-17651-A
-------	-------	--------------

## WINDSHIELD WASHER RESERVOIR CAP



This stamped aluminum cap secures tightly unlike the original and it looks great.

**Windshield Washer Reservoir Cap**  
64-65 .....C1AZ-17618-CAP

## WIPER COMPONENTS

### EXTERNAL WIPER BEZEL NUT TOOL



Specially designed for removing or installing bezel nuts, without risk of scratching or damaging bezel or paint.

**External Wiper Bezel Nut Tool**  
64-65 .....T-120-BL

### WINDSHIELD WIPER ARM



Excellent reproductions of the originals, with stainless steel arm construction.

**Windshield Wiper Arm**  
64-65 Smooth end cap, polished C1SZ-17526-A  
66-70 Flanged end cap, polished C1SZ-17526-B  
66-70 Flanged end cap, satin .....C1SZ-17526-S

### WINDSHIELD WIPER ARM AND BLADE KIT



A convenient kit which makes sales easy. Each kit contains two wiper arms and two blade assemblies.

**Windshield Wiper Arm and Blade Kit**  
64-65 Stainless steel .....KIT-WIP-5  
66-68 Stainless steel .....KIT-WIP-6

### WINDSHIELD WIPER BEZEL AND NUT KIT



These are perfect reproductions of the originals. Bezels are pressure cast in zinc and then finely chrome plated. Nuts

are chromed plated brass. Sold in sets with two bezels and two nuts.  
**Windshield Wiper Bezel and Nut Kit**  
64-65 .....CSZZ-17514-K

## WINDSHIELD WIPER BLADE ASSEMBLY



Good quality Trico Assembly. Stainless steel construction. Includes one wiper blade assembly and one rubber blade.

**Windshield Wiper Blade Assembly**  
65-68 15 inch length .....C3AZ-17528-J  
69-70 16 inch length .....C9AZ-17528-A  
71-73 18 inch length .....D1ZZ-17528-A

### WINDSHIELD WIPER BLADE REFILL



Quality name brand replacement blades. Made in the U.S.A. by Trico.

**Windshield Wiper Blade Refill**  
64-68 15 inch length .....C3AZ-17593-C  
69-70 16 inch length .....C9AZ-17593-A  
71-73 18 inch length .....D1ZZ-17593-A

### WINDSHIELD WIPER MOTOR



Replacement 2-speed wiper motor for all 1967-70 Mustangs.

**Windshield Wiper Motor**  
67-70 .....C7ZZ-17508

### WINDSHIELD WIPER PIVOT SEAL



Wiper seals are high quality and reliable. Originals were leather.

**Windshield Wiper Pivot Seal**  
64-66 Leather .....CSZZ-17A475-BL  
64-70 Rubber/foam .....CSZZ-17A475-B  
67-70 Leather .....C7ZZ-17A475-BL

### WINDSHIELD WIPER SWITCH



**Windshield Wiper Switch**  
64-65 1 speed w/out washer ...CSZZ-17A553-B  
65-66 1 speed w/ washer .....CSZZ-17A553-C  
65-66 2 Speed w/ washer .....CSZZ-17A553-D  
69 2 Speed .....C9ZZ-17A553-A  
70 2 Speed .....D0ZZ-17553-A  
71-73 2 speed .....D1ZZ-17553-A

## VARIABLE WINDSHIELD WIPER SWITCH



Wiper switches for multiple applications.

**Windshield Wiper Switch, Variable**  
64-66 1 speed with control for washer .....  
CSZZ-17A553-V1  
64-66 Variable, 2 speed with control for washer  
CSZZ-17A553-V2  
69-70 Variable speed with control for washer ..  
C9ZZ-17A553-V2  
71-73 Variable speed w/ control for washer .....  
D1ZZ-17A553-V2

### WINDSHIELD WIPER SWITCH RETAINING NUT



This beautifully chromed nut holds the wiper switch into the dash. This nut is almost always damaged from improper tools

used for removal and installation. Made from original factory prints.

**Windshield Wiper Switch Retaining Nut**  
65-66 .....C4DZ-17512-A

### WIPER BEZEL STEM NUT TOOL



Special tool designed to insert into wiper bezel stem nut used for assembly or disassembly. Will not damage nut.

**Wiper Bezel Stem Nut Tool**  
64-66 .....T-110-RD

### WIPER TRANSMISSION ARM



New trans arms for smooth, even motion.

**Wiper Transmission Arm**  
65-66 .....CSZZ-17566/7-A  
67-68 .....C7ZZ-17566/7-A

**WE PROUDLY FEATURE AUTHENTIC MUSTANG REPRODUCTIONS FROM SCOTT DRAKE ENTERPRISES!**



